

MECHANIZED INFANTRY PLATOON AND SQUAD (BRADLEY)

CONTENTS

	page
Preface	vii
CHAPTER 1. DOCTRINE	
Section I. Fundamentals	1-1
1-1. Mission	1-1
1-2. Combat Power	1-2
1-3. Leader Skills	1-4
1-4. Soldier Skills	1-4
1-5. Training	1-4
Section II. Platoon Operations	1-5
1-6. Considerations for Employment	1-5
1-7. Movement	1-5
1-8. Offense	1-7
1-9. Defense	1-11
1-10. Security	1-14

DISTRIBUTION RESTRICTION—Approved for public release; distribution is unlimited.

*This publication supersedes FM 7-7J, 18 February 1986.

CHAPTER 2. OPERATIONS

Section I. Command and Control	2-1
2-1. Mission Tactics	2-1
2-2. Troop-Leading Procedure	2-3
2-3. Operation Order Format	2-13
2-4. Fire Control and Distribution	2-40
Section II. Security	2-53
2-5. Security During Movement	2-53
2-6. Security in the Offense	2-54
2-7. Security in the Defense	2-55
Section III. Movement	2-57
2-8. Formations	2-57
2-9. Movement Techniques	2-67
2-10. Actions at Danger Areas	2-73
Section IV. Offense	2-77
2-11. Movement to Contact	2-77
2-12. Attacks	2-85
2-13. Conduct of a Deliberate Attack	2-87
2-14. Consolidation and Reorganization	2-91
Section V. Defense	2-93
2-15. Conduct of the Defense	2-93
2-16. Defensive Techniques	2-101
2-17. Basic Tactics	2-113
2-18. Priority of Work	2-114
2-19. Weapons Emplacement	2-116
2-20. Range Cards	2-122
2-21. Types of Positions	2-135
2-22. BFV Positions	2-135
2-23. Squad Positions	2-135
2-24. Platoon Positions	2-136
2-25. Sector Sketches	2-136
2-26. Fire Control Measures	2-140
2-27. Coordination	2-140
2-28. Fighting Positions	2-140
Section VI. Other Operations	2-160
2-29. Withdrawal	2-160
2-30. Delay	2-168

	page
2-31. Retirement	2-169
2-32. Linkup	2-169
2-33. Stay-Behind Operations	2-170
2-34. Relief in Place	2-171
2-35. Air Assault Operations	2-172
Section VII. Fire Support	2-174
2-36. Offensive Fire Support Planning	2-174
2-37. Defensive Fire Support Planning	2-174
2-38. Techniques of Indirect Fire Control	2-175
2-39. Technique for Direct-Fire Support From BFVs	2-178
Section VIII. Combat Service Support	2-179
2-40. Planning	2-179
2-41. Resupply Operations	2-179
2-42. Resupply Techniques	2-180
2-43. Other Resupply Considerations	2-182
2-44. Maintenance	2-185
2-45. Personnel Service Support	2-187
2-46. Health Services Support	2-191
Section IX. Bradley Fighting Vehicle and Tank Operations	2-193
2-47. Movement With Tanks	2-193
2-48. Communication With Tanks	2-195
Section X. Obstacles	2-196
2-49. Employment of Obstacles	2-196
2-50. Types of Obstacles	2-197
2-51. Enemy Obstacles	2-209
2-52. Breaching and Clearing of Obstacles	2-210
Section XI. Nuclear, Biological, and Chemical Operations	2-215
2-53. Operations in a Nuclear Environment	2-215
2-54. Operations in a Chemical and Biological Environment	2-218
Section XII. Observation Posts	2-231
2-55. Considerations	2-231
2-56. Actions at the Observation Post	2-232
2-57. Squad-Sized Observation Post	2-233
2-58. Visual Terrain Search	2-233

	page
Section XIII. Limited Visibility Techniques	2-235
2-59. Equipment Considerations	2-235
2-60. Limited Visibility Offense	2-237
2-61. Movement Considerations	2-237
2-62. Movement Formations	2-237
2-63. Movement Techniques	2-238
2-64. Navigation Technique	2-238
2-65. Identification	2-243
2-66. Attacks	2-243
2-67. Infiltration	2-247
2-68. Limited Visibility Defense	2-250
2-69. Positions	2-251
2-70. Command and Control in Limited Visibility Defense	2-252
2-71. Coordination	2-253
2-72. Occupation of a Defensive Position	2-254

CHAPTER 3. BATTLE DRILLS AND CREW DRILLS

Section I. BATTLE DRILLS	3-2
Battle Drill 1. Platoon Attack (Dismounted)	3-3
Battle Drill 1A. Platoon Attack (Mounted)	3-11
Battle Drill 2. React to Contact (Platoon or Squad)(Dismounted)	3-18
Battle Drill 2A. React to Contact (Section or Platoon) (Mounted)	3-21
Battle Drill 3. Break Contact (Platoon or Squad) (Dismounted)	3-23
Battle Drill 3A. Break Contact (Section or Platoon) (Mounted)	3-26
Battle Drill 4. React to Ambush (Platoon or Squad) (Dismounted)	3-28
Battle Drill 4A. React to Ambush (Platoon) (Mounted)	3-30
Battle Drill 5. Enter Building/Clear Room/Building (Platoon)	3-32
Battle Drill 6. Enter/Clear a Trench (Platoon)	3-38

	page
Battle Drill 7. Knock Out Bunkers (Platoon)	3-44
Battle Drill 8. Conduct Initial Breach of a Mined Wire Obstacle (Platoon)	3-48
Section II. CREW DRILLS	3-53
Crew Drill 1. Bail Out (Crew/Fire Team)	3-54
Crew Drill 2. Evacuate Injured Personnel From a BFV	3-55
Crew Drill 3. Extinguish a Fire (Crew)	3-58
Crew Drill 4. Dismount the Vehicle (Platoon/Squad) . .	3-60
Crew Drill 5. Mount the Vehicle (Platoon/Section) . .	3-62
Crew Drill 6. Change Formation (Mounted) (Platoon)	3-64
Crew Drill 7. Secure at the Halt (Platoon)	3-80
Crew Drill 8. Execute Action Right or Left (Platoon)	3-85
Crew Drill 9. Load the 25-mm Ammunition Ready Box (HE or AP)	3-92
Crew Drill 10. Engage Targets With the 25-mm Automatic Gun or 7.62-mm Coax (Crew)	3-96
Crew Drill 11. Reload a TOW Launcher (Crew) . . .	3-97
Crew Drill 12. Engage Targets With the TOW (Crew)	3-99
Crew Drill 13. Remove a Misfired TOW (Crew) . . .	3-100
Crew Drill 14. Load, Unload, and Stow Grenades for the M257 Smoke Grenade Launcher (Crew)	3-101
Crew Drill 15. Destroy or Abandon an M2 Bradley Fighting Vehicle (Crew)	3-102
Crew Drill 16. Perform Before-, During-, and After-Combat-Operation Checks (Crew)	3-105

**CHAPTER 4. MECHANIZED INFANTRY PLATOON
TACTICAL STANDING OPERATING
PROCEDURES**

	page
APPENDIX A. ORGANIZATION	A-1
APPENDIX B. BRADLEY PLATOON REFERENCE GUIDE	B-1
APPENDIX C. STINGRAY EMPLOYMENT	C-1
APPENDIX D. M249 EMPLOYMENT	D-1
GLOSSARY	Glossary-1
REFERENCES	References-1
INDEX	Index-1

PREFACE

This manual discusses the tactics, techniques, and procedures for the mechanized infantry platoon and squad equipped with the M2 Bradley fighting vehicle (BFV). Mechanized infantry leaders must know the capabilities of the soldiers and the BFV to develop overwhelming combat power at the decisive place and time. Maneuver, firepower, protection, and leadership combine to form the dynamics of combat power.

The BFV platoon and squad must fight dismounted and mounted under all types of battlefield conditions. This manual provides the general guidance, but judgment must be used in application after carefully considering each situation.

The proponent of this publication is US Army Infantry School. Submit changes for improving this publication on DA Form 2028 (Recommended Changes to Publications and Blank Forms) and forward it to the Commandant, US Army Infantry School, ATTN: ATSH-ATD, Fort Benning, GA 31905-5410.

Unless other wise stated, whenever the masculine gender is used, both men and women are included.

CHAPTER 1

DOCTRINE

The US Army's basic fighting doctrine is called AirLand Battle. It reflects time proven fundamentals, the structure of modern warfare, and the experience of combat. AirLand Battle doctrine provides a specific mission for mechanized infantry forces.

Section I

FUNDAMENTALS

Among the mechanized infantry's basic fundamentals are the principles of war, the dynamics of combat power, and the tenets of AirLand Battle. These fundamentals have application at the platoon and squad level. This section provides the mission of the mechanized infantry and the doctrine principles basic to the mechanized infantry rifle platoon and squad (Bradley). These principles form the basis for platoon and squad tactics, techniques, procedures, and drills. The section also discusses the dynamics of combat power and the skills required of leaders and soldiers at the small-unit level.

1-1. MISSION

The mission of the mechanized infantry is to close with the enemy by means of fire and maneuver to defeat or capture him, or to repel his assault by fire, close combat, and counterattack.

a. Despite any technological advantages that our armed forces might have over an enemy, only close combat between ground forces gains the decision in battle. Mechanized infantry rifle forces have a key role in close combat situations. They—

- Attack over approaches that are not feasible for armored forces.
- Make initial penetration and retain existing (natural and man-made) obstacles and difficult terrain as pivots for operational and tactical maneuver.
- Seize or secure forested and built-up areas.
- Control restrictive routes for use by other forces.

- Operate primarily at night or during other periods of natural or induced limited visibility.
- Conduct rear area operations.

b. The Bradley fighting vehicle provides—

- Mobile protected transport of sufficient infantry to the critical point on the battlefield.
- Fires to support the dismounted infantry.
- Fires to suppressor destroy enemy IFV and light-armor vehicles.
- Antiarmor fires to destroy enemy armor.

c. Success in battle hinges on the actions of platoons, elements, sections, and squads in close combat; on their ability to react to contact, employ suppressive fires, maneuver to a vulnerable flank, and fight through to defeat, destroy, or capture an enemy. The successful actions of the BFV platoon relies on the ability of leaders and soldiers to maximize the potential of both the infantry and BFV, to use terrain to good advantage; to operate their weapons with accuracy and deadly effect; to out think, out move, and out fight the enemy.

d. Mechanized infantry rifle platoons and squads normally operate as part of a larger force. They benefit from the support of other infantry units, armor, artillery, mortars, close air, helicopters, air defense, and engineer assets. They also provide their own suppressive fires either to repel enemy assaults or to support their own maneuver.

1-2. COMBAT POWER

The doctrine that guides mechanized infantry forces is based on the four dynamics of combat power: maneuver, firepower, protection, and leadership.

a. **Maneuver.** Maneuver is the movement of forces supported by fire to achieve a position of advantage from which to destroy or threaten destruction of the enemy. Mechanized infantry forces move to gain a position of advantage over the enemy and to hold that advantage. They maneuver to attack enemy flanks, rear areas, logistics points, and command posts. In the defense, they maneuver to counterattack a flank of the enemy attack. Maneuver, properly supported by fires, allows the mechanized infantry to close with the enemy and gain a decision in combat.

b. **Firepower.** Firepower is the capacity of a unit to deliver effective fires on a target. Firepower kills or suppresses the enemy in his positions, deceives the enemy, and supports maneuver. Without effective supporting

fires the mechanized infantry cannot maneuver. Before attempting to maneuver, units must establish a base of fire. A base of fire is fire placed on an enemy force or position to reduce or eliminate the enemy's ability to interfere with friendly maneuver. A base of fire maybe provided by a single weapon or a grouping of weapon systems. Leaders must know how to control, mass, and combine fire with maneuver. They must identify the most critical targets quickly, direct fires onto them, and ensure that the volume of fires is sufficient to keep the enemy from returning fire effectively, and the platoon from expending ammunition needlessly.

c. Protection. Protection is the conservation of the fighting potential of a force so that it can be applied at the decisive time and place. Platoons must never permit the enemy to acquire an unexpected advantage. Platoons and squads take active and passive measures to protect themselves from surprise, observation, detection, interference, espionage, sabotage, or annoyance. Protection includes two basic considerations: care of the soldier and his equipment, and action to counter enemy combat power.

(1) The first consideration involves sustainment techniques necessary to maintain the platoon and squads as an effective fighting force. It includes keeping soldiers healthy to maintain fighting morale through personal hygiene, physical conditioning, and rest plans. It also includes keeping equipment in good working condition, and providing and protecting supplies.

(2) The second involves security, dispersion, cover, camouflage, deception, and suppression of enemy weapons. Mechanized infantry units gain protection by digging fighting positions when stationary for any length of time; by skillful use of terrain while moving mounted; by dismounting the infantry to increase protection; and through overwatch and suppressive fires and obscuration. The mechanized infantry always wants to set the time and place of battle, and it must protect itself so that it can do so with maximum combat power and the important element of surprise.

d. Leadership. Military leadership is a process by which a soldier influences others to accomplish the mission. Leaders coordinate the other three elements of combat power. Their competent and confident leadership results in effective unit action. The right leadership gives purpose, direction, and motivation in combat. Leaders must know their profession, their soldiers, and the tools of war. Only this kind of leader can direct soldiers to do difficult tasks under dangerous and stressful conditions. Leadership is the most important element of combat power.

1-3. LEADER SKILLS

Bradley infantry leaders must be versatile. They cannot rely on a book to solve tactical problems. They must understand and use initiative in accomplishing the mission. This means that they must know how to analyze the situation quickly and make decisions rapidly in light of the commander's intent. They must be prepared to take independent action if necessary. The art of making sound decisions quickly lies in the knowledge of tactics, the estimate process, and platoon and squad techniques and procedures. The skills required of Bradley infantry leaders include physical toughness, technical and tactical knowledge, mental agility, and a firm grasp of how to motivate soldiers to fight on in the face of adversity.

1-4. SOLDIER SKILLS

Soldiers with sharply honed skills form the building blocks of combat effective units. They must maintain a high state of physical fitness. They must be experts in the use of their primary weapons and vehicle weapon systems. They must be proficient in infantry skills (land navigation, camouflage, individual movement techniques, survival techniques, and so forth). Finally, they must know and practice their roles as members of fire teams, squads, crews, sections, and platoons.

1-5. TRAINING

Bradley infantry units must train properly for combat. Training must conform to Army doctrine. Doctrinal manuals provide leaders correct procedures and principles to conduct training properly. Leaders and soldiers must understand standardized doctrinal principles found in applicable publications. They should refer to ARTEP 7-7J-MTP and ARTEP 7-7J-DRILL to find the specific conditions and standards for the techniques and procedures discussed in this manual. Training must require leaders to use their initiative and make decisions quickly. The training environment must be realistic and stressful. Training must challenge soldiers to master all mechanized infantry tasks, individual and collective, and it must constantly remind them of their mission, their heritage, and the physical and mental toughness that is required of them. Unit training must also promote the cohesion of the unit so that, when all else fails, units continue to fight.

Section II

PLATOON OPERATIONS

This section describes the three basic tactical operations undertaken by mechanized infantry platoons and squads—movement, offense, and defense. It also discusses the requirement for security, which is inherent in all platoon operations.

1-6. CONSIDERATIONS FOR EMPLOYMENT

Leaders must consider the following in employing mechanized infantry tactics.

a. Squads and platoons fight through enemy contact at the lowest possible level. All soldiers and their leaders must know their immediate reactions to enemy contact as well as their follow-up actions. Battle drills are the standard procedures used to enable soldiers and their leaders to do this. (Battle drills are discussed in Chapter 3.)

b. Squads or platoons in contact must establish effective suppressive fires to gain fire superiority before they can maneuver. If the platoon or squad cannot move under its own fires, the leader must request support from higher headquarters. The platoon must attempt to gain fire superiority and then maneuver against an enemy position.

c. Squads and platoons will fight as organized. The platoon fights by elements, mounted and dismounted, and the squad fights by fire teams. Fire teams, squads, and elements retain their integrity. The mounted element fights by sections (wingman concept). The platoon leader and his wingman are Section A; the platoon sergeant and his wingman are Section B. Even buddy teams stay the same. The team leader and the automatic rifleman form one buddy team, and the grenadier (M203) or automatic rifleman or an antiarmor specialist form the other buddy team. Success depends on all soldiers understanding what the unit is trying to do and the specific steps necessary to accomplish the mission.

d. The platoon leader waits for the section/squad in contact to develop the situation. Anytime a BFV or fire team makes contact, the platoon also begins taking action. That way the platoon can quickly provide additional support, maneuver to take up the assault, or follow-up on the success of the section or squad that made contact after they develop the situation.

1-7. MOVEMENT

Movement refers to the shifting of forces on the battlefield. The key to moving successfully involves selecting the best combination of formations and movement techniques in each situation. Leaders consider the factors of mission, enemy, terrain, and troops and time available (METT-T) in

selecting the best route and the appropriate formation and movement technique. The leader's selection must allow moving units to—

- Maintain cohesion.
- Maintain momentum.
- Provide maximum protection.
- Make contact with the smallest force possible.
- Make contact in a manner that allows them to transition smoothly to offensive or defensive action. During planning, the platoon leader must designate dismount points en route to the objective, and look for possible dismount points as the platoon moves toward the objective.

a. **Vehicles and Formations.** Formations are arrangements of units and of soldiers in relation to each other. Platoons and squads use formations for control, security, and flexibility.

(1) **Control.** Every unit, vehicle, and soldier has a standard position. Soldiers can see their team leaders. Bradley commanders can see their wingmen and fire team leaders can see their squad leaders. Leaders control their units using arm-and-hand signals.

(2) **Security.** Formations also provide 360-degree security and allow units to give the weight of their firepower to the flanks or front in anticipation of enemy contact.

(3) **Flexibility.** Formations do not demand parade ground precision. Platoons must retain the flexibility needed to vary their formations to the situation. The use of formations allows platoons and squads to execute battle drills more quickly and gives soldiers the assurance that their leaders and buddy team members are in their expected positions and performing the right tasks.

b. **Movement Techniques.** Movement techniques describe the position of vehicles, squads, and fire teams in relation to each other during movement. Platoons and squads use three movement techniques: traveling, traveling overwatch, and bounding overwatch. Leaders base their selection of a particular movement technique on the likelihood of enemy contact and the requirement for speed. Movement techniques provide varying degrees of control, security, and flexibility. Movement techniques differ from formations in two ways.

(1) Formations are relatively fixed; movement techniques are not. The distance between moving teams/squads/sections or the distance that a team/squad/section bounds away from an overwatching team/squad/section varies based on factors of METT-T

(2) Formations allow the platoon to weight its maximum firepower in a desired direction; movement techniques allow platoons to make contact with the enemy with the smallest element possible. This allows leaders to establish a base of fire, gain suppressive fires, and attempt to maneuver without first having to disengage or be reinforced.

c. **Other Considerations.** In planning tactical movement, leaders also consider the requirements for—

- Reconnaissance.
- Dispersion.
- Security.
- Cover and concealment.
- Speed.
- Observation and fields of fire.
- Maneuver space.
- Command and control.
- Dismount points en route to the objective.

1-8. OFFENSE

Platoons and squads undertake offensive operations to destroy the enemy and his will to fight; to seize terrain; to learn enemy strength and disposition; or to deceive, divert, or hold the enemy. Mechanized infantry platoons and squads normally conduct offensive operations as part of a larger force. However, they can perform some offensive operations independently. Offensive operations include movements to contact, attacks, raids, reconnaissance and security operations, and ambushes.

a. **Movement to Contact.** A movement to contact is an attack that seeks to gain or regain contact with the enemy. Usually, a platoon moving to contact lacks detailed information about the enemy. The platoon uses traveling, traveling overwatch, or bounding overwatch based on the likelihood of enemy contact and the need for speed. Upon making contact, a lead BFV or fire team identifies the enemy strengths and weaknesses as it develops the situation. A platoon conducts a movement to contact as part of a company. Considerations for planning and conducting movements to contact include—

- Making enemy contact with the smallest element possible.
- Preventing detection of elements not in contact until they are in the assault.
- Maintaining 360-degree security at all times.
- Reporting all information quickly and accurately.

- Maintaining contact once it is gained.
- Generating combat power rapidly upon contact.
- Fighting through at the lowest level possible.

b. **Types of Attack.** An attack is an offensive action characterized by movement supported by fire. There are two types of attack: hasty and deliberate. They are distinguished chiefly by the time available for preparation. Additionally, special-purpose attacks include raids and ambushes. Successful attack depends on concentrating the maximum possible shock and violence against the enemy force. Mechanized infantry forces combine shock and violence with surprise. The objective is to shatter the enemy's nerve, ruin his synchronization, unravel his plan, and destroy his unit's cohesion and the willingness of his soldiers to fight. A successful attack combines a scheme of maneuver with a coordinated plan of direct and indirect fire support. The focus of an attacking platoon's fire and maneuver is a weak point, a vulnerable flank, or the rear of an enemy. Once he has identified the point of attack, the leader establishes a base of fire to kill, fix, or suppress the enemy at that point. He then maneuvers the rest of his force to a position from which it can assault.

(1) **Hasty attack.** A hasty attack is conducted with the forces immediately available to maintain momentum or to take advantage of the enemy situation. It does not involve extensive preparation in comparison to a deliberate attack.

(2) **Deliberate attack** A deliberate attack is carefully planned and coordinated. More time is available to perform thorough reconnaissance, evaluation of all available intelligence and relative combat strength, analysis of various courses of action, and other factors affecting the situation. It is generally conducted against a well-organized defense when a hasty attack is not possible or has been conducted and failed.

(3) **Raid.** A raid is a swift penetration of hostile territory to secure information, to confuse the enemy, or to destroy his installations. It ends with a planned withdrawal after completion of the assigned mission.

(4) **Ambush.** An ambush is a surprise attack by fire from concealed positions on a moving or temporarily halted enemy unit. It combines the advantages and characteristics of the offense with those of the defense.

c. **Initiative in the Attack.** Seizing and retaining the initiative involves more than just achieving tactical surprise. It involves a process of planning and preparing for combat operations, finding the enemy first, avoiding detection, fixing the enemy, locating or creating a weakness, and maneuvering to exploit that weakness with a quick and violent assault.

(1) **Plan and prepare.** Leaders use the troop-leading procedure to make sure that all necessary steps are taken to prepare for a mission. Leaders use the estimate of the situation to analyze the factors of ME'TT-T and to determine the best course of action and to ensure that leaders, soldiers, and their equipment can perform the tasks necessary to accomplish the mission.

(2) **Find the enemy.** Platoon leaders find the enemy by knowing how he fights, by analyzing the terrain in light of this knowledge, and by actively reconnoitering to locate him.

(3) **Avoid detection.** Platoons avoid detection by moving along the least expected route; platoons use terrain to mask their movements. They use proper camouflage techniques and move with stealth. This allows platoons to Capitalize on surprise. All of this requires imagination in leaders and stamina in soldiers.

(4) **Fix the enemy.** Platoons, sections, and squads fix enemy forces by employing suppressive fires that kill exposed enemy soldiers and destroy their weapons. As a minimum, they render the volume and accuracy of the enemy's fire ineffective.

(5) **Find or create a weakness.** Leaders look for vulnerable flanks, gaps in lines, or lulls in enemy fire. When they cannot readily find a weakness, they create one with suppressive fire coupled with the surprise effect of suddenly coming from an unexpected direction.

(6) **Maneuver to exploit the weakness.** Leaders must exploit this weakness by moving to the best covered and concealed position and then assaulting to destroy, defeat, or capture the enemy.

(7) **Consolidate and reorganize.** Finally, platoons and squads must quickly consolidate the position to defend it against an enemy counterattack. They then reorganize themselves and prepare to continue the mission.

d. **Control Measures.** Leaders use graphic control measures to regulate or direct the platoon's movement, positions, and fire.

(1) Control measures are not intended to restrict the exercise of initiative (the function of command). Leaders use control measures to clarify their intent, focus the platoon and squad effort, and ensure synchronization. Each control measure should have a specific purpose that contributes to mission accomplishment. If a control measure fails the purpose test, leaders should not use it.

(2) Control measures can be drawn on a map, overlay, sketch, or a terrain model. Leaders should strive to keep control measures easily identifiable and simple. Graphic control measures in the offense

include assembly area, attack position, line of departure, boundaries, route, release point, start point, axis of advance, limit of advance, direction of attack, phase line, checkpoint, assault position, objective, contact point, linkup point, infiltration lane, probable line of deployment, and limit of advance. FM 101-5-1 discusses these control measures in detail and provides examples of their use.

e. **Attacks During Limited Visibility.** Attacks during limited visibility achieve surprise, avoid heavy losses, cause panic in a weak and disorganized enemy, exploit success, maintain momentum, and keep pressure on the enemy. Platoons and squads attack whenever possible during limited visibility. Darkness, fog, heavy rain, falling snow, and the smoke and dust of combat create limited visibility conditions that allow infantry platoons and squads to move undetected.

(1) **Fundamentals.** The fundamentals for a daylight attack apply to limited visibility attacks. Limited visibility attacks require—

- Well-trained platoons.
- Sufficient light to employ night vision devices.
- A simple concept with sufficient control measures.
- Detailed, successful reconnaissance of the objective, routes, passage points, support-by-fire positions, and other key locations.

(2) **Considerations.** Leaders must consider the increased difficulty during limited visibility operations in performing the following:

- Controlling the movement of vehicles; individuals; and platoons, squads, and sections.
- Identifying targets and controlling direct and indirect fires.
- Navigating and moving.
- Identifying friendly and enemy vehicles and soldiers.
- Locating, treating, and evacuating casualties.
- Locating and bypassing or breaching enemy obstacles.

f. **Infiltration.** Infiltration is a form of maneuver in the offense. It is a means of reaching the enemy's rear without fighting through prepared defenses. Mechanized infantry platoons infiltrate to move into or through an area as stealthily as possible. An infiltration is not an end in itself but a means to an end.

(1) Platoons infiltrate—

- To gather information.
- To attack enemy positions from the rear.

- To conduct raids or ambushes in enemy rear areas.
- To capture prisoners.
- To seize key terrain in support of other operations.
- To aid a main attack.

(2) An infiltration has five phases (a squad or section is the smallest element that should infiltrate).

(a) *Patrol*. Find gaps, weak areas in enemy defenses and enemy positions.

(b) *Prepare*. Make plans, give orders, coordinate with forward and flank units, and rehearse.

(c) *Infiltrate*. Use the specified infiltration method. Avoid contact. Ignore ineffective enemy fire.

(d) *Consolidate*. Do this in the enemy rear or along a final linkup point; then, move to an objective rally point to continue the mission.

(e) *Execute*. Carry out the assigned mission. The mission can be attack, raid, seize key terrain or an area, capture prisoners, or gather information.

(3) Three methods of infiltration are—

(a) *Multiple lanes*. When many gaps exist and the terrain can support a large number of lanes, each platoon or squad uses its own lane.

(b) *Single lane—staggered time*. Platoons or squads move along a single lane at staggered times. This method can be used when few gaps exist or when the ground restricts the number of lanes.

(c) *Single lane—same time*. A single gap exists on which the whole platoon can move at the same time.

1-9. DEFENSE

Platoons and squads normally defend as part of a larger force to disrupt, disorganize, delay, or defeat an attacking enemy, deny an area to an enemy, or protect a flank. They may also defend as a part of a larger unit in a retrograde operation. The challenge to the defender is to retain the initiative, that is, to keep the enemy reacting and unable to execute his own plan.

a. **Types of Defense.** A defense is a coordinated effort by a force to defeat an attacker and prevent him from achieving his objective. The two types of defense are hasty and deliberate. They are distinguished chiefly by the time available for preparation. Defensive techniques used in these two types of defenses include perimeter defense, defense of a battle position, defense in sector, defense of a strongpoint, and reverse-slope defense. These techniques are discussed in Chapter 2, Section V.

(1) **Hasty defense.** A hasty defense is normally organized while in contact with the enemy or when contact is imminent and time to organize is limited. It is characterized by improvement of natural defensive strengths of the terrain by using fighting positions, emplacement, and obstacles.

(2) **Deliberate defense.** A deliberate defense is a defense normally organized when out of contact with the enemy or when contact with the enemy is not imminent and time for organization is available.

b. **Initiative in the Defense.** Since the enemy decides the time and place of the attack, leaders seize and retain the initiative in the defense through careful planning, preparation, coordination, and rehearsal. Leaders plan and establish the defense to find the enemy first, without being found; fix the enemy with obstacles and fires; locate or create a weakness in the enemy's attack plan; and maneuver to exploit that weakness with quick violent counterattacks.

(1) **Plan and prepare.** Leaders use the troop-leading procedure to make sure that all necessary steps are taken to prepare for a mission. They analyze the factors of METT-T to determine the best course of action. In the defense, they determine where best to kill the enemy, and they position obstacles to canalize him to that point. They position key weapons to concentrate fires into the killing area and cover obstacles with fire. Leaders position the remaining platoon and squad weapons to support and protect the key weapons and cover obstacles. They reconnoiter and rehearse counterattacks.

(2) **Find the enemy.** Platoon leaders find the enemy by knowing how he fights, by analyzing the terrain in light of this knowledge, by positioning OPs along likely avenues of approach, and by actively patrolling to locate him.

(3) **Avoid detection.** Platoons avoid detection by moving into the defensive position during darkness if possible, using proper camouflage techniques and by practicing good noise, light, and litter discipline. This allows platoons to capitalize on surprise. All of this requires imagination in leaders and stamina in soldiers.

(4) **Fix the enemy.** Platoons use a combination of tactical obstacles and direct and indirect fires to disrupt the enemy attack and fix the enemy in a place where the platoon can destroy him with fires.

(5) **Find or create a weakness.** Platoons create a weakness by destroying the enemy's command and control nodes, by isolating an attacking or assaulting enemy formation from its support, by causing mounted forces to dismount and thereby slowing the attack and making the enemy vehicles more vulnerable, by use of night vision devices to gain

a visibility advantage, or by the effective use of illumination to blind or expose the enemy during his attack.

(6) **Maneuver to exploit the weakness.** Having created a weakness, platoons must exploit it with counterattacks against the flank or rear of the enemy attack by fire or maneuver. Units must carefully coordinate and rehearse all counterattacks to ensure the proper synchronization in lifting and shifting of direct and indirect fires. They must also consider the threat of follow-on enemy forces against their counterattack.

(7) **Reorganize.** Platoons and squads must be able to reorganize quickly to continue the defense against follow-on forces.

c. **Control Measures.** Leaders use control measures to assign responsibilities, coordinate fires and maneuver, control combat operations, and clarify their concept of the operation. Additionally, control measures ensure the distribution of fires throughout the unit's area of responsibility and the initial positioning and subsequent maneuver of units.

(1) Graphic control measures used in the defense include sectors, battle positions, unit boundaries, contact points, coordination points, forward edge of the battle area (FEBA), strongpoints, target reference points (TRP), assembly areas, phase lines, passage points and lanes, release points, and engagement areas. FM 101-5-1 discusses these control measures in detail and provides examples of their use.

(2) Fire commands and control measures for individual and key weapons also constitute a type of control measure available to leaders. Weapons control measures include range cards, sectors of fire, principle direction of fire, final protective line, final protective fires, and target reference points. Most of these appear on the range card. Chapter 2 describes the requirements for weapons range cards and provides examples. In addition, antiarmor gunners, fire teams, squads, and platoons can be given engagement priorities and fire commands.

d. **Obstacles.** Obstacles give strength to a defense when properly employed. Platoons and squads incorporate existing (natural and man-made) obstacles into their defense and construct other obstacles, reinforcing systems with mines and wire.

(1) **Considerations.** Leaders must integrate their obstacle plans with direct and indirect fire plans and with their scheme of maneuver. Platoons always cover obstacles by fire and observation. They protect obstacles with antipersonnel mines, trip flares, and warning devices. They camouflage wire or hide it in natural terrain features. Chapter 2 discusses the techniques of obstacle employment most common to mechanized infantry platoons and squads.

(2) **Classifications.** Wire obstacles have three classifications based on their use and location. Priority for emplacement normally goes to tactical wire. Additionally, leaders can organize their obstacles so that one obstacle can serve both tactical and protective functions.

(a) **Tactical.** The platoon leader sites tactical wire parallel to and along the friendly side of the FPLs of major weapons. Tactical wire holds the enemy where he can be killed or wounded by automatic rifle fire, Claymores, hand grenades, machine gun fire, and 25-mm gun fire and antiarmor fire.

(b) **Protective.** Platoons locate protective wire to prevent surprise assaults from points close to the defense area. The wire normally lies just outside of hand-grenade range and well within both day and night observation.

(c) **Supplementary.** These obstacles are used to breakup the line of tactical wire to prevent the enemy from locating friendly weapons (particularly the machine guns) by following the tactical wire.

1-10. SECURITY

Security is protection which includes any measure taken by platoons and squads against actions that may reduce their effectiveness. It involves avoiding detection by the enemy or deceiving the enemy about friendly positions and intentions. It also includes reconnaissance to find the enemy and to learn as much about his positions and intentions as possible. Security allows units to retain freedom of action and is an important part of maintaining the initiative. The requirement for security is an inherent part of all platoon operations. Platoons and squads secure themselves when they move, attack, and defend. As part of a larger formation, they may undertake security operations that involve patrolling; establishing squad-and section-sized OPs on a screen line; or executing advance, flank, or rear guard missions for the main body in a movement to contact.

a. **Security During Movement.** Platoons and squads enhance security during movement by—

- Using the proper movement formation and technique.
- Moving as fast as the situation will allow. This may degrade the enemy's ability to detect the unit and the effectiveness of his fires once detected.
- Moving along terrain that offers cover and concealment.
- Enforcing noise, litter, and light discipline.
- Using proper camouflage techniques.

b. **Security in the Offense.** Security in the offense includes reconnaissance and security **missions** to locate the enemy and protect friendly forces from surprise while leaving them free to deploy when contact **is** made with the enemy. All platoons and squads are responsible for their own local security. They may also be given specific reconnaissance and security tasks as part of the company or battalion plan. Platoons and squads conduct patrols, establish OPs, and move using appropriate movement formations and techniques to accomplish both reconnaissance and security tasks.

c. **Security in the Defense.** In the defense, platoons and squads use both active and passive measures to enhance security. Platoons also add to their security by actions taken to deny **enemy** reconnaissance elements accurate information on friendly positions. This includes the destruction of enemy reconnaissance elements and the use of deception measures.

(1) Active measures include—

- The use of OPs and patrols.
- The establishment of specific levels of alert within the platoon. The level can be adjusted based on the METT-T situation.
- The establishment of stand-to times. The platoon's SOP should detail the platoon's activities for stand-to.

(2) Passive measures include—

- Camouflage.
- Movement control.
- Noise, litter, and light discipline.
- Proper radiotelephone procedures.
- Ground sensors, night vision devices, and antiarmor weapons' day and nightsights.

CHAPTER 2

OPERATIONS

This chapter provides techniques and procedures used by mechanized infantry platoons, sections, and squads. These techniques are used throughout the planning and execution phases of platoon and squad tactical operations.

Section I

COMMAND AND CONTROL

This section discusses mission tactics, troop-leading procedure, combat orders, and techniques for preparing a platoon to fight. These topics pertain to all combat operations. Their application requires time. With more time, leaders can plan and prepare in depth. With less time, they must rely on previously rehearsed actions, battle drills, and standing operating procedures.

2-1. MISSION TACTICS

Mission tactics is the term used to describe the exercise of command authority by a leader. Mission tactics places the relationship of command, control, and communications in proper perspective by emphasizing the predominance of command. This emphasis on command, rather than control, provides for initiative, the acceptance of risk, and the rapid seizure of opportunities on the battlefield. Mission tactics can be viewed as freedom of action for the leader to execute his mission in the way he sees fit, rather than being told how to do it. Mission tactics reinforced by the knowledge of the higher commander's intent and focused on a main effort establishes the necessary basis for small-unit leadership.

a. The philosophy of mission tactics extends throughout all levels of command. Leaders must be provided the maximum freedom to command and have imposed on them only the control necessary to synchronize mission accomplishment. Sometimes leaders must issue specific instructions. Normally, this is necessary when the platoon's actions must be synchronized with other actions. Mission tactics, as a command philosophy, recognizes the many tools available to the leader but

emphasizes that there is no substitute for the personal element of command.

b. Mission tactics causes every leader to understand and accomplish his mission in consonance with the commander's mission. Execution of mission tactics requires initiative, resourcefulness, imagination, and selfless subordination of one's personal interest to accomplish the higher commander's intent. Initiative must be driven by the commander's intent, not merely by a desire for independent action. Leaders must be resourceful enough to adapt to situations as they are, not as they were expected to be.

c. Platoon, section, and squad leaders must also effectively control their subordinates. Control restricts command. Generally, increased control leads to less application of command. Not all control is bad or counterproductive. For example, doctrine is a form of control in that all leaders expect their subordinates to understand and apply the principles of doctrine. Another common source of control is the use of graphics for operation overlays. While optional and situationally dependent, these are restrictive and must be reviewed by the leader before implementation. Each control measure must have a specific purpose that contributes to mission accomplishment. If it does not pass this purpose test, it unnecessarily restricts freedom of action and should not be used.

d. Control is necessary to synchronize the actions of elements participating in an operation. The more complex the operation, the greater the need for control. The challenge to leaders is to provide the minimal amount of control required and still allow for decentralized decision making in each situation.

(1) Mission tactics requires that leaders learn *how* to think rather than *what* to think. It recognizes that the subordinate is often the only person at the point of decision who can make an informed decision. Guided by the commander's intent, the mission, and the concept of the operation, the leader can make the right decision.

(2) At platoon and squad level, useful forms of control include common doctrine, mission, concept of the operation, time, and control measures.

(a) Doctrine, especially in the form of battle drills and platoon SOPs that prescribe away of performing a task, provides an element of control. By limiting the ways in which a task is performed to standard, battle drills and platoon SOPs provide a common basis for action; allow for quick, practiced responses; decrease the probability for confusion and loss of cohesion; and reduce the number of decisions to the essential minimum.

(b) The mission statement of the platoon is also a form of control. Its purpose provides the basis for decision and allows freedom of action. Its focuses on establishing the main effort and focuses all other actions toward mission accomplishment.

(c) The concept of the operation identifies the main and supporting efforts for the higher unit and describes how a commander sees the execution of the operation. This allows the maximum possible freedom of action for the subordinate leader tasked with executing the main effort. Leaders executing the supporting effort will have less freedom of action, because they must key their actions on the main effort. The concept of the operation also details the control of fires and other combat multipliers that must be synchronized and focused on the main effort.

(d) Leaders use time to control their platoons, squads, or individuals by establishing specifically when a task should begin or be complete. Control using time is especially critical when the platoon's and squad's actions must be synchronized with other platoons, squads, or supporting elements.

(e) Another source of control is the use of control measures. These include instructions to subordinate squads and sections, fire commands, and the use of operational graphics in overlays. While normally optional and situationally dependent, control measures are potentially restrictive and must be reviewed by leaders before incorporating them into their plans. To ensure the proper amount of control, each control measure must have a specific purpose that contributes to mission accomplishment. If it does not pass this test, it unnecessarily restricts freedom of action and should not be used.

e. Platoon, section, and squad leaders use mission tactics to accomplish the mission. They give orders and instructions that communicate the higher commander's intent, the mission (task and purpose) of the platoon, and the concept of the operation to include control measures. Leaders also use mission tactics to ensure that subordinates understand that they are to use initiative in making decisions when the situation changes.

2-2. TROOP-LEADING PROCEDURE

Troop leading is the procedure leaders use to prepare their platoons, squads, sections, or teams to accomplish a tactical mission. It begins when the leader is alerted for a mission. It starts again when he receives a change or a new mission. The troop-leading procedure comprises the steps listed below. Steps 3 through 8 may not follow a rigid sequence. Many of them may be accomplished concurrently. In combat, rarely will leaders have enough time to go through each step in detail. Leaders must

use the procedure as outlined, if only in abbreviated form, to ensure that nothing is left out of planning and preparation, and that their soldiers understand the platoon and squad mission and prepare adequately. They continuously update their estimates throughout the preparation phase and adjust their plans as appropriate.

STEP 1 Receive the mission.

STEP 2. Issue a warning order.

STEP 3. Make a tentative plan.

STEP 4. Start necessary movement.

STEP 5. Reconnoiter.

STEP 6. Complete the plan.

STEP 7. Issue the complete order.

STEP 8. Supervise.

a. **STEP 1. Receive the Mission.** The leader may receive the mission in a written or oral warning order, an operation order (OPORD), or a fragmentary order (FRAGO). He immediately begins to analyze it using the factors of METT-T

- What is the MISSION?
- What is known about the ENEMY?
- How will TERRAIN and WEATHER affect the operation?
- What TROOPS are available?
- How much TIME is available?

(1) The leader should use no more than one third of the available time for his own planning and for issuing his operation order. The remaining two thirds is for subordinates to plan and prepare for the operation. Leaders should also consider other factors such as available daylight and travel time to and from orders and rehearsals.

(2) In scheduling preparation activities, the leader should work backwards from the LD or defend time. This is reverse planning. He must allow enough time for the completion of each task.

b. **STEP 2. Issue a Warning Order.** The leader provides initial instructions in a warning order. The warning order contains enough information to begin preparation as soon as possible. Platoon SOPs should prescribe who will attend all warning orders and the actions they must take upon receipt; for example, drawing ammunition, rations and water, and checking communications equipment. The warning order has no specific format. One technique is to use the five-paragraph OPORD format. The leader issues the warning order with all the information he

has available at the time. He provides updates as often as necessary. If available, the following information may be included in a warning order. The leader never waits for information to fill a format. A sample warning order is in Figure 2-1.

- The mission or nature of the operation.
- Who is participating in the operation.
- Time of the operation.
- Time and place and who will attend the issuance of the operation order.

FORMAT	ANNOTATED FORMAT	EXAMPLE, ORAL (ATTACK)
SITUATION	Brief description of the enemy and friendly situations. Point out key locations on the ground, map, or sketch. Attachments and detachments to the squad/platoon.	<p>"This is a warning order. Hold your questions until I finish.</p> <p>"The recon platoon has identified a motorized rifle platoon with at least two BTRs defending Hill 876, vic GL123456. They are digging in and it looks like they plan to defend the road junction at GL126463. The rest of the enemy company is further to the west, around Hill 899.</p> <p>"Captain Williams just issued a warning order for the company to prepare to conduct an attack at 110200 July to seize Hill 876 in order to provide suppressive fires for the battalion's main attack on Hill 899.</p> <p>"There are no attachments or detachments.</p>
MISSION	Concise statement of the mission which includes the task and purpose (who, what, when, where, and why). If not all information is known, state which parts of the mission statement are tentative.	<p>"3d Plt attacks 110200 Jul 91 to seize Hill 876 (GL123456) in order to provide fires on Hill 899 in support of the battalion's attack.</p>
EXECUTION	Brief statement of the tentative concept of the operation.	<p>"We will be one of the two assault platoons along with 2d Plt. 1st Plt will be the base of fire along with the company mortars.</p>

Figure 2-1. Example of platoon warning order.

FORMAT	ANNOTATED FORMAT	EXAMPLE, ORAL (ATTACK)
<p>EXECUTION (continued)</p>	<p>Time schedule: Earliest time of move. Time and place of OPORD. Probable execution time. Inspection times and items to be inspected different from SOP. Rehearsal time, location, and actions to be rehearsed.</p>	<p>"Time schedule is as follows: LD time is 0200. The earliest we will have to move is 2330. After 2330, we have to be ready to move within 10 minutes of the order to do so. My final inspection will be at 2300, here at the CP. We have a company rehearsal for team leaders on up, at 1600 at the company CP. We will meet here at 1530 and move together. I want a platoon rehearsal for team leaders, squad leaders, section leaders, the aidman, the FO, and SFC Fowler (the PSG) here at our CP at 1330. We will do a full platoon rehearsal at 2100 so we can do it at least once in the dark. Platoon rehearsals will be for actions at the objective. Squads rehearse breaching and react to contact drills on your own. My OPORD will be here at the platoon CP at 1030. I want the orders group present.</p>
<p>Tasks to subordinate key personnel: Platoon sergeant Bradley commanders Squad leaders RATELO Aidman Attachments To soldiers helping prepare OPORD. As needed to others.</p>	<p>"SFC Fowler, you will control the mounted element during our dismounted assault on the objective. Talk to me about resupply after this warning order. I want you to plan for casualty evacuation and to give paragraph 4 of the OPORD. "Bradley commanders do a good PMCS and prefire checks on the BFY. "SSG Crawford, take your squad and recon the routes from here to the LD. "SGT Brown (FO), I need you to get the fire plan from the FIST ASAP, so we can see what additional targets we need.</p>	

Figure 2-1. Example of platoon warning order (continued).

FORMAT	ANNOTATED FORMAT	EXAMPLE, ORAL (ATTACK)
		<p>"SSG Steele, send SGT White and his team here in 20 minutes to begin making the terrain model of the objective."</p>
SERVICE SUPPORT	<p>Additional general instructions. CSS tasks to be accomplished that are different from the tactical SOP.</p>	<p>"Each squad will carry four AT4s to use against the BTRs or any bunkers we find."</p>
COMMAND AND SIGNAL	<p>Location of CP succession of command (if not SOP). SOI in effect. Signals/code words.</p>	<p>"No change to platoon organization. The platoon CP will stay here. SOI we have is still in effect."</p>
		<p>"The time is now 0620. What are your questions?"</p>

Figure 2-1. Example of platoon warning order (continued).

c. **STEP 3. Make a Tentative Plan.** The leader develops an estimate of the situation to use as the basis for his tentative plan. The estimate is the military decision making process. It consists of five steps: detailed mission analysis, situation analysis and course of action development, analysis of each course of action, comparison of each course of action, and decision. The decision represents the tentative plan. The leader updates the estimate continuously and refines his plan accordingly. He uses this plan as the start point for coordination, reconnaissance, task organization (if required), and movement instructions. He works through this problem solving sequence in as much detail as time available allows. As the basis of his estimate, the leader considers the factors of METT-T.

(1) **Mission.** The leader considers his mission as given to him by his commander. He analyzes it in light of the commander's intent two command levels higher, and he derives the essential tasks his platoon must perform in order to accomplish the mission.

(2) **Enemy.** The leader considers the type, size, organization, tactics, and equipment of the enemy he expects to encounter. He identifies the enemy's, strengths and weaknesses.

(3) **Terrain.** The leader considers the effect of terrain and weather on enemy and friendly forces using the guidelines below (OAKOC):

(a) **Obstacles.** In the attack, the leader considers the effect of restrictive terrain and enemy obstacles on his ability to maneuver. In the defense he considers how he will tie in his obstacles to the terrain to disrupt, turn, fix, or block an enemy force and protect his own forces from enemy assault. He also considers how he will cover the obstacles by direct or indirect fire.

(b) **Avenues of approach.** An avenue of approach is an air or ground route of an attacking force of a given size leading to its objective or key terrain in its path. In the offense, the leader identifies the avenue of approach that affords him the greatest protection and places him at the enemy's most vulnerable spot. In the defense, the leader positions his key weapons along the avenue of approach most likely to be used by the enemy.

(c) **Key terrain.** Key terrain is any locality or area whose seizure or retention affords a marked advantage to either combatant. The leader considers key terrain in his selection of objectives, support positions, and routes in the offense, and on the positioning of his platoon in the defense.

(d) **Observation and fields of fire.** The leader considers ground that allows him observation of the enemy throughout his area of operation. He considers fields of fire in terms of the characteristics of the weapons available

to him; for example, maximum effective range, the requirement for grazing fire, and the arming range and time of flight for antiarmor weapons.

(e) *Cover and concealment.* The leader looks for terrain that will protect him from direct and indirect fires (cover) and from aerial and ground observation (concealment).

(f) *Weather.* In considering the effects of weather, the leader is most interested in visibility and trafficability.

(4) *Troops available.* The leader considers the strength of squads, the characteristics of his weapon systems, and the capabilities of attached elements as he assigns tasks to squads and sections.

(5) *Time available.* The leader refines his allocation of time based on his mission and reverse planning sequence and all other known deadlines.

d. **STEP 4. Start Necessary Movement.** The platoon may need to begin movement while the leader is still planning or reconnoitering forward. The platoon sergeant or a squad leader may bring the platoon forward, usually under the control of the company executive officer or first sergeant. This step could occur at any time during the troop-leading procedure.

e. **STEP 5. Reconnoiter.** The platoon leader makes a map reconnaissance and if time allows, he makes a personal reconnaissance to verify his terrain analysis, adjust his plan, confirm the usability of routes, and time any critical movements. The leader must consider the risk inherent in conducting reconnaissance forward of friendly lines. Sometimes the leader must rely on others (for example, reconnaissance platoon) to conduct the reconnaissance if the risk of contact with the enemy is high.

f. **STEP 6. Complete the Plan.** The leader completes his plan based on the reconnaissance and any changes in the situation. He should review his mission, as he received it from his commander, to ensure that his plan meets the requirements of the mission and stays within the framework of the commander's intent.

g. **STEP 7. Issue the Complete Order.** Platoon and squad leaders normally issue oral operation orders.

(1) To aid subordinates in understanding the concept for the mission, leaders should issue the order within sight of the objective or on the terrain to be defended. A terrain model or sketch is always helpful.

(2) Leaders must ensure that subordinates understand the mission, the commander's intent two levels up, the concept of the operation, and their assigned tasks. Leaders may require subordinates to repeat all or part of the order or demonstrate on the model or sketch their

understanding of the operation. Leaders should also quiz their soldiers to ensure that all soldiers understand the mission. Chapter 4 provides a list of questions that leaders can ask their soldiers to determine their understanding.

h. STEP 8. Supervise. The leader supervises the platoon's preparation for combat by conducting rehearsals and inspections.

(1) **Rehearsals.** If possible, leaders should conduct rehearsals on terrain that resembles the actual ground and in similar light conditions. The platoon may begin rehearsals of battle drills and other SOP items before the receipt of the operation order. Once the order has been issued, the platoon can rehearse mission-specific tasks. The leader uses rehearsals to—

- Practice essential tasks (improve performance).
- Reveal weaknesses or problems in the plan.
- Coordinate the actions of subordinate elements.
- Improve soldier understanding of the concept of the operation (foster confidence in soldiers).

The types of rehearsals are *briefback*, *reduced force*, and *full force*. There are many different techniques available to accomplish these rehearsals. Some important tasks to rehearse include actions in the assembly area, actions before LD, actions en route to the assault position or objective, actions in the assault position, actions on the objective, and actions during consolidation and reorganization on the objective.

(a) **Briefback** Briefbacks identify problems and disconnects in execution but to a lesser degree than hands-on rehearsals. The platoon leader should conduct at least two briefbacks with subordinate leaders. When possible, he should conduct briefbacks collectively at a meeting of the orders group. This makes the exchange of information easier, improves coordination among platoons and squads, and speeds the distribution of changes.

- The first briefback is done immediately after the platoon OPORD has been issued. This briefback is to ensure subordinate leaders understand the platoon's mission.
- The second briefback is done after subordinates have formulated their own concept, but before they have issued their OPORD. This briefback is to ensure the platoon and subordinate concepts agree before subordinate leaders issue their OPORD.

(b) *Reduced-force rehearsal (key leaders)*. A reduced-force rehearsal is done when time is limited or the tactical situation does not permit everyone to attend. The platoon replicates its actions on mock-ups, sand tables, or smaller pieces of terrain than the actual operation.

(c) *Full-force rehearsal*. This type of rehearsal is the most effective, but uses the most time and resources. It involves every soldier who will participate in the operation. If possible it should be conducted under the same conditions (weather, time of day, terrain, and so on) that is expected to be encountered during the actual operations.

(2) *Techniques of rehearsal*. The techniques areas follows.

(a) *Force on force*. This technique is used during full-force rehearsals. Platoons rehearse in good visibility on open terrain before gradually increasing to realistic conditions. The platoon rehearses with squads/sections going force on force against each other or the entire platoon going force on force against another platoon in the company.

(b) *Map*. A map rehearsal may be conducted with a single map overlay. A map rehearsal limits the number of participants. Time and space constraints are very limited.

(c) *Radiotelephone*. This is used when time and enemy situation do not allow for the gathering of personnel; to test radios and determine backup systems in the event of communication equipment failure; and to rehearse key elements of the platoon plan such as the fire support matrix and execution of reserve obstacles.

(d) *Sand table or terrain model*. This technique is used when time is limited. Participants are the key leaders. This technique is normally conducted without vehicles. Training aids must be built large enough so all personnel can observe. Graphic features are included (such as phase lines, trigger points, objectives, and TRPs) and may include other items as necessary in painting a word picture.

(e) *Rock/stick drill*. This is similar to a sand table or terrain model. The difference is that participants either move themselves, rocks, sticks, or anything else to replicate their actions or their platoon's actions.

(f) *TEW'T (tactical exercise without troops)*. The platoon normally conducts a TEWT as part of a larger force. Very few assets are required, normally just key leaders participate. This technique is most effective when used with wheeled vehicles upon key terrain.

(3) *Inspections*. Section and squad leaders should conduct initial inspections shortly after receipt of the warning order. The platoon sergeant spot-checks throughout the platoon's preparation for combat.

The platoon leader and platoon sergeant make a final inspection. They should inspect—

- Weapons and ammunition.
- Uniforms and equipment.
- Mission-essential equipment.
- Soldier's understanding of the mission and their specific responsibilities.
- Communications.
- Rations and water.
- Camouflage.
- Deficiencies noted during earlier inspections.

2-3. OPERATION ORDER FORMAT

An operation order (OPORD) is a directive issued by the leader to his subordinate leaders in order to effect the coordinated execution of a specific operation.

a. The leader briefs his OPORD orally from notes that follow the five-paragraph format below (Figure 2-2).

FORMAT	ANNOTATED FORMAT	EXAMPLE, ORAL (ATTACK)	EXAMPLE, ORAL (DEFEND)
<p>TASK ORGANIZATION</p>	<p>Task Organization: Explain how operation, if there is no change to previous task organization, indicate "no change."</p>	<p>"Task organization is 1st and Sections A and B are the base-of-fire element.</p>	<p>"No change. 2d Squads are the assault element,</p>
<p>1. SITUATION</p>	<p>1. SITUATION: Provide information essential to the subordinate leader's understanding of the situation.</p>	<p>SITUATION</p>	<p>SITUATION</p>
<p>a. Enemy Forces.</p>	<p>a. Enemy Forces. Refer to the overlay or sketch. Include pertinent intelligence provided by higher HQ and other facts and assumptions about the enemy. This analysis is stated as conclusions and addressed— (1) Disposition, composition, and strength. (2) Capabilities. A listing of what the enemy is able to do and how well. (3) Most probable course of action.</p>	<p>"The reconnaissance platoon has confirmed a full strength motorized rifle squad on our portion of the company objective. They are dug in and expected to fight hard to retain this terrain.</p>	<p>"An enemy motorized rifle battalion about 85 percent strength is expected to attack from the northeast, moving along the east side of Comanche Road, sometime during the night of 12 June. The MRB will be a supporting attack from the regiment's main attack. We should see the regimental reconnaissance sometime during the night of 11 June, and the MRB's CRP on the afternoon of 12 June.</p>

Figure 2-2. Example of platoon operation order.

FORMAT	ANNOTATED FORMAT	EXAMPLE, ORAL (ATTACK)	EXAMPLE, ORAL (DEFEND)
<p>b. Friendly Forces.</p>	<p>b. Friendly Forces. Provide information that subordinates need to accomplish their tasks.</p> <p>(1) Higher unit. A verbatim statement of the higher unit commander's mission statement from paragraph 2 and concept of the operation statement from paragraph 3a.</p> <p>(2) Left unit's mission.</p> <p>(3) Right unit's mission.</p> <p>(4) Forward unit's mission.</p>	<p>"Company C attacks 110200JUN92 to seize Hill 652 (OBJ BULL), vicinity GL163831 to prevent the MRP on OBJ BULL from concentrating combat power against the battalion main effort, Company A on OBJ DOG.</p> <p>"Company A (battalion main attack) clears OBJ DOG in the vicinity of GL165872 to prevent the enemy on that position from disrupting future CS and CSS operations.</p> <p>"1/C/2-66 infantry (mechanized) suppresses the enemy on OBJ CAT to allow 2d Platoon to breach and seize OBJ BIRD, then fix the enemy on OBJ FISH to allow 3d Platoon (company main effort) an unimpeded movement to OBJ CAT; then follow and assume the main effort and seize OBJ FISH.</p>	<p>"Company A defends NLT 121000JUN92 to destroy the enemy, vicinity EA FOX (GL123456) and EA PUP (GL127439), and prevent the envelopment of Company B from the south.</p> <p>"2d Platoon is the company main effort. They are on our left. They will defend BP 3 to destroy the enemy in EA FOX.</p> <p>"Company A, 2/66 Infantry is on our right. They are defending along the high ground in their sector to destroy enemy forces and prevent envelopment of our company from the south.</p> <p>"Reconnaissance platoon screens forward of our company BP and will withdraw through 3d Platoon.</p>

Figure 2-2. Example of platoon operation order (continued).

FORMAT	ANNOTATED FORMAT	EXAMPLE, ORAL (ATTACK)	EXAMPLE, ORAL (DEFEND)
	<p>(5) Mission of the unit in reserve or following.</p> <p>(6) Units in support or reinforcing the higher unit.</p> <p>c. Attachments and Detachments. When not shown under Task Organization, list here or in an annex, units attached or detached from the platoon, together with the effective times.</p>	<p>"2/C/2-66 Infantry attacks to create a breach point and seize OBJ BIRD to prevent a counter-attack against the company.</p> <p>"The battalion mortar platoon is to our rear and will provide supporting fires for our assault on OBJ CAT and FISH to prevent enemy from reinforcing enemy in the vicinity of GL162878 (OBJ DOG).</p> <p>None</p>	
<p>2. MISSION</p>	<p>2. MISSION: Provide a clear, concise statement of mission, which includes the task to be accomplished, the unit, and the purpose for doing it (who, what, when, where, and why). The leader derives the mission from his mission analysis.</p>	<p>"3d Platoon attacks 110130JUN92 to seize high ground in the vicinity of GL165855 (OBJ CAT) to prevent the enemy from reinforcing enemy in the vicinity of GL165862 (OBJ DOG), on order fix the enemy on OBJ FISH to support 1st Platoon's attack on OBJ FISH.</p>	<p>MISSION</p> <p>"1st Platoon defends Hill 202 (BP 2) NLT 121000JUN92 to destroy enemy in vicinity of EA FOX and PUP to prevent the envelopment of 2d Platoon from the south.</p>

Figure 2-2. Example of platoon operation order (continued).

FORMAT	ANNOTATED FORMAT	EXAMPLE, ORAL (ATTACK)	EXAMPLE, ORAL (DEFEND)
<p>3. EXECUTION Intent.</p>	<p>3. EXECUTION: Intent. Give the stated vision that defines the purpose of the operation and the relationship among the force, the enemy, and the terrain. At battalion level and below, the intent may be the same as the purpose of the mission statement. If so, there is no requirement to restate it here.</p>	<p>EXECUTION "We will accomplish our part of the company's mission by systematically attacking to seize the high ground on OBJ CAT to prevent the enemy from reinforcing the enemy on OBJ DOG. We will divide the platoon objective into two squad objectives. The mounted element will provide suppressive fire on</p>	<p>EXECUTION "I want the mounted element to destroy at least 9 enemy vehicles in EA PUP, then immediately move to primary positions in BP 2 and be prepared to destroy another company-sized element in EA FOX. In EA FOX, the dismounted elements will prevent the enemy dismounted troops and engineers from breaching the minefields, obstacles, and from enveloping 2d Platoon from the south. Section B and 2d Squad will be a reserve to counter any enemy attempt at envelopment from the south. At the end of this battle, I want to have at least 3 BFVs combat capable to move on a counterattack, with 85 percent of dismounted soldiers combat effective.</p>
<p>a. Concept of the Operation. Refer to the operation overlay and concept sketch. Explain, in general terms, how the platoon, as a whole, will accomplish the mission.</p>	<p>"Our part of the company mission is in three phases. Phase I will be the preparation phase of the main defensive position. Phase II will be the forward fight in EA PUP, and Phase III will be the main fight in EA FOX.</p>		

Figure 2-2. Example of platoon operation order (continued).

FORMAT	ANNOTATED FORMAT	EXAMPLE, ORAL (ATTACK)	EXAMPLE, ORAL (DEFEND)
	<p>If applicable, designate the decisive point, form of maneuver or defensive techniques, and any other significant factors or principles. Limit this paragraph to six sentences.</p>	<p>OBJ 1 and 2. 1st Squad will seize OBJ 1; then 2d squad will follow to seize OBJ 2.</p>	
<p>(1) Maneuver.</p>	<p>(1) Maneuver. Address all elements, sections, squads and attachments by name. Designate the platoon's main effort; that is, who will accomplish the most important task for the platoon. (All other tasks must relate to the main effort. Give task and purpose for each subordinate element.)</p>	<p>"We will attack with 1st Squad following 2d Platoon through the breach to destroy the BTR-70 and suppress the enemy trench to allow 2d Squad to seize OBJ 2. 2d Squad (main effort) follows 1st Squad to attack and destroy the bunkers in the vicinity of OBJ 2, preventing the enemy from reinforcing against OBJ DOG. The mounted element will provide suppressive fire on OBJ 1 and 2 to support 1st and 2d Squads' assault on OBJ 1 and 2; then consolidate on the objective on order.</p>	<p>"Phase I, we will deploy with 1st Squad on the left, in the north; and 2d Squad on the right. Both squads are overlooking the main obstacle belt and are oriented east into EA FOX. 1st Squad will orient fires from TRP 09 to TRP 06 to destroy the enemy in EA FOX. Employ your Dragon on the right flank with a sector between TRP 09 and TRP 06. The primary direction of fire is toward TRP 08. You are the main effort.</p> <p>"2d Squad orient your fires from TRP 08 to TRP 07 to destroy the enemy in EA FOX, employ your Dragon on the right flank, oriented between TRP 09 and TRP 07. Establish a secondary sector of fire east southeast, from just north of OP 1 to south of Route 2 and passage point 2, to prevent the enemy from enveloping our position from the south. All vehicle positions will be two-tier, and Dragon positions will have overhead cover first.</p>

Figure 2-2. Example of platoon operation order (continued).

FORMAT	ANNOTATED FORMAT	EXAMPLE, ORAL (ATTACK)	EXAMPLE, ORAL (DEFEND)
		<p>"Phase II, the mounted element, under my command, will move forward just before dark 12 Jun 92 to hasty positions in the vicinity of BP 1, and orient north into EA PUP to destroy the enemy entering the EA .</p> <p>Section A on the left and Section B on the right.</p> <p>"Section A orient from TRP 01 to TRP 04. Engagement priority is tanks, ADA vehicles, C2 vehicles, BMPs, and engineer equipment.</p> <p>"Section B orient from TRP 03 to TRP 04, engagement priority is BMPs, ADA vehicles, C2 vehicles, troops.</p> <p>"Engage on order. I want this to be like an ambush. Continue to engage until ordered to cease fire, or at least 9 enemy vehicles are destroyed. On order, we will withdraw to BP 2. Order of march is Section A, then Section B using bounding overwatch.</p> <p>Section A will cover Section B's move to passage point 2 along Route 2. Section B will then cover Section A from passage point 2. All vehicles will move to prepared positions in BP 2 and wait for orders.</p>	<p>"Phase III, when the enemy enters EA FOX and reaches the first minefield, I will initiate fires.</p>

Figure 2-2. Example of platoon operation order (continued).

FORMAT	ANNOTATED FORMAT	EXAMPLE, ORAL (ATTACK)	EXAMPLE, ORAL (DEFEND)
			<p>"Section A in the north, orient fires between TRP 09 and TRP 07 to destroy the enemy in EA FOX. Engagement priority is BMPs, ADA vehicles, C² vehicles, tanks." 1st Squad orient from TRP 09 to TRP 06 and deny enemy dismounted infantry or engineers from breaching the wire and mine obstacles and enveloping 2d Platoon from the south.</p> <p>"Section B in the south, orient fires between TRP 08 and TRP 06 to destroy the enemy in EA FOX. Engagement priority is tanks, engineer vehicles, ADA vehicles, C² vehicles, and BMPs. 2d Squad orient between TRP 08 and TRP 07 and deny the enemy troops from breaching the wire and mine obstacles to your front and enveloping 2d Platoon from the south." If OP 1 detects the enemy trying to maneuver around our right flank, all BFVs will go to supplementary position BP 2C oriented in the direction of passage point 2. 2d Squad and its Dragon will occupy supplementary positions oriented toward passage point 2 and all elements will engage and destroy all enemy attempting to envelop our position. 1st Squad continues to guard to the front. If the enemy in EA FOX returns to assault our position, I will direct all weapons</p>

Figure 2-2. Example of platoon operation order (continued).

FORMAT	ANNOTATED FORMAT	EXAMPLE, ORAL (ATTACK)	EXAMPLE, ORAL (DEFEND)
<p>(2) Fires.</p>	<p>(2) Fires. Refer to the fire support overlay and target list. Describe how the task and purpose of fire support the scheme of maneuver. If applicable, address priority of fires (include changees), priority targets (who controls fires on them), and any restrictive control measures on the use of fires.</p>	<p>"The commander will prepare the objective before the attack to support the company maneuver onto the objective. Company priority of fire is 2d Platoon, then to us. I will control the platoon fires. Use TRPs to adjust fire as we attack the objective.</p>	<p>to fire into EA FOX, and continue to fire until all the enemy is destroyed, by using the code word SMASH.</p> <p>"There are battalion mortars in support, but Company B has priority of fires. In our Company, 2d Platoon has priority of fires. "Fires will be used to button up the enemy, and kill his dismounted infantry and engineers. Smoke will be used to obscure his vision.</p> <p>"There are four targets in EA PUP, and five in EA FOX.</p> <p>"TRPs 01, 02, 03, and 04 in EA PUP will be used to button up the enemy and help channelize him into EA FOX.</p> <p>"TRP 09 is the priority target.</p> <p>"TRPs 08, 06, 07, 10 will be used to suppress, obscure all mounted elements and kill all dismounted troops attempting to breach. TRP 10 will be called if the enemy attempts to assault our position. 2d Squad leader will initiate that target. The succession of command to initiate that target is platoon sergeant, then 1st Squad leader.</p>
	<p>(3) Additional combat support assets. State the concept of employment of any combat support assets of who gets priority of their use, how they are to be</p>		

Figure 2-2. Example of platoon operation order (continued).

FORMAT	ANNOTATED FORMAT	EXAMPLE, ORAL (ATTACK)	EXAMPLE, ORAL (DEFEND)
	<p>used (priority of effort), and how they will be controlled and by whom.</p>		
<p>b. Tasks to Combat Units.</p>	<p>b. Tasks to Maneuver Units. Specify tasks, other than those listed in paragraph 3a(1), and the purpose of each, for squads and attachments. List each in separate numbered subparagraphs. Address the reserve last. State any priority or sequence. (Do not include information that belongs in the Coordinating Instructions subparagraph.)</p>	<p>"1st Squad, follow 2d Platoon through the breach and destroy the BTR-70 in the vicinity of GL161828, then provide suppressive fire on the bunkers on OBJ 2 to support 2d Squad's assault on OBJ 2. "2d Squad provide the suppressive fire to isolate OBJ 2 when 1st Squad assaults OBJ 1, then assault OBJ 2 and clear bunkers 1 through 4. "Mounted element provide suppressive fires to support 1st and 2d Squads' assault on OBJ 1 and 2. On purple smoke, shift fires from OBJ 1 to OBJ 2 to suppress for 2d Squad's assault. On green smoke, shift fires to OBJ FISH to suppress any fires directed at 2d Squad's assault. On order, consolidate on OBJ CAT near the bunkers, facing east to establish a support-by-fire position toward OBJ FISH. On order, support by fire 1st Platoon's assault of OBJ FISH. On order, 1st and 2d Squads consolidate to the north side and provide early warning of attack from that direction.</p>	<p>"1st Squad occupy and prepare BP 2A, prepare your supplementary position here (point out on terrain model), to prevent a flank attack. Prepare OP 1 and construct obstacle 1. "Mounted element occupy and prepare BP 2B. "2d Squad occupy and prepare BP 2C, prepare OP 2, and construct obstacle 3.</p>
<p>c. Tasks to Combat Support Units.</p>	<p>c. Tasks to Combat Support Units. A platoon may receive assets of CS units; for example, an engineer squad. List tasks to CS units in subparagraph in the order they appear in the organization. List only those specific tasks that must be accomplished by these units not specified elsewhere.</p>		

Figure 2-2. Example of platoon operation order (continued).

FORMAT	ANNOTATED FORMAT	EXAMPLE, ORAL (ATTACK)	EXAMPLE, ORAL (DEFEND)
<p>d. Tasks to Subordinate Elements.</p>	<p>d. Tasks to Subordinate Elements. Specify tasks and purpose of each squad, section, or attachment. List in separate numbered subparagraph. Address the reserve last. State any priority or sequence. Do not include any information that belongs in coordinating instructions.</p>		<p>"1st Squad, occupy BP 1A, oriented northeast, and destroy all dismounted troops in sector, and any tanks along Comanche Road. Construct obstacle 1. Assist in the preparation of minefield 2. Conduct reconnaissance and security patrols from the right flank of 2d Platoon to the left flank of our platoon along the wire obstacle. One patrol every two hours.</p> <p>"2d Squad, construct obstacle 1. Assist in the preparation of minefield 2. Conduct reconnaissance and security patrols from OP 1 through passage point 2 and along the right flank of the platoon position.</p> <p>Establish OP 1. Man passage point 2 from 121800JUN92 until the completion of the passage of the mounted element. Occupy BP 2A, oriented northeast. Destroy all enemy dismounted troops in the sector, and any tanks in the vicinity of the far minefield along Comanche Road.</p> <p>"Section A (mounted), initially, defend forward in BP 1. Occupy on the left. Orient between TRP 01 and 04. Destroy enemy in EA PUP, engagement priority is tanks, ADA vehicles, C² vehicles, BMPs. On order, cover the withdrawal of Section B back to BP 2.</p>

Figure 2-2. Example of platoon operation order (continued).

FORMAT	ANNOTATED FORMAT	EXAMPLE, ORAL (ATTACK)	EXAMPLE, ORAL (DEFEND)
	<p>e. Coordinating e. Coordinating Instructions. List the details of coordination and control applicable to 2 or more units in the platoon. Items that may be addressed include—</p> <ul style="list-style-type: none"> Priority intelligence requirements, and intelligence requirements, and reporting tasks. MOPP level. 	<p>"The order of march during movement is 31, 30, 32, 33 to the assault position. Dismounted 1st Squad followed by 2d Squad in the attack. We will use traveling overwatch to the assault position, and bounding overwatch with dismounted squads bounding overwatched by BFVs</p>	<p>In BP 2, occupy northern positions oriented between TRP 09 and TRP 07. Engagement priority is BMPs, ADA vehicles, C2 vehicles.</p> <p>"Section B (mounted), initially, defend forward in BP 1. Occupy on the right. Oriented between TRP 03 and 04. Destroy enemy in EA PUP. Primary engagement priority: BMPs, engineer vehicles, C2 vehicles, dismounted troops. On order, bound back to passage point 2. Upon passage, turn and cover the withdrawal of Section A through passage point 2. Occupy the southern position on BP 2, oriented between TRP 08 and TRP 06. Engage the enemy in priority: tanks, engineer vehicles, ADA vehicles, C2 vehicles, BMPs.</p> <p>"All elements are responsible for constructing protective and tactical wire obstacles. PSG will supervise emplacement.</p> <p>"ADA Status: YELLOW; TIGHT.</p> <p>"MOPP2 until 112400JUN92.</p> <p>"MOPP3 112400JUN92 to 120400JUN92.</p> <p>"MOPP4 on order.</p> <p>"Security is 20 percent until 112000JUN92;</p>

Figure 2-2. Example of platoon operation order (continued).

FORMAT	ANNOTATED FORMAT	EXAMPLE, ORAL (ATTACK)	EXAMPLE, ORAL (DEFEND)
	Troop safety and operational exposure guidance.	through the breach. "We will depart the AA at 112130RJUN.	50 percent from 112000JUN92 to defend time.
	Engagement and disengagement criteria and instructions.	"The H-hour sequence for this operation is as follows: "At H-5 minutes, 1st platoon in support-by-fire position. "At H-3 minutes, The 4.2-inch mortar preparation on the trench line will begin.	"No vehicle movement after 12000JUN92 until passage back from forward positions. "Inspections: Initial—Element leaders 111600JUN92. Prefinal—PSG 1117000JUN92. Final—Platoon leader 111820JUN92.
	Fire distribution and control measures.	"At H-hour 120430RJUN, 2d platoon will conduct the breach. "ADA weapons status is HOLD. "MOPP2 is in effect.	"Rehearsals: Company: 111200JUN92. Platoon:
	Consolidation and reorganization instructions (other than SOP items).	"Consolidation will be as depicted on the consolidation concept sketch upon seizure of OBJ 2. "Report the following immediately: "Minefields, enemy MOPP levels, in positions, BTR-70 destroyed, trench line cleared, all tanks observed.	1. Movement route back to BP 2 from BP 1. 2. Engagement plan. "PIRs: Any signs of engineers in MOPP clothing. Any heavy engineer equipment.
	Reporting requirements.		
	Terrorism and counter-terrorism instructions.		
	Specified tasks that pertain to more than one squad or element.		
	Rules of engagement		
	Order of march and other movement instructions (consider an annex).	"Timing: 11 June 1300 Pit rehearsal	

Figure 2-2. Example of platoon operation order (continued).

FORMAT	ANNOTATED FORMAT	EXAMPLE, ORAL (ATTACK)	EXAMPLE, ORAL (DEFEND)
		<p>1400 Co rehearsal 1700 Inspection 1730 Chow 1830 Rest 2100 Night rehearsal 12 June 0015 Stand-to 0045 Final inspection 0130 LD time 0430 Assault time</p>	
<p>4. SERVICE SUPPORT</p>	<p>4. SERVICE SUPPORT. Include CSS instructions and arrangements supporting the operation that are of primary interest to the platoon. Include changes to established SOPs or a previously issued order. Paragraph 4 is often prepared and issued by the PSG.</p>	<p>SERVICE SUPPORT "Company trains are at GL118400. "Class I, T-MRE-T. "LOGPAC 1600 daily. All vehicles will be topped-off before 111200JUN92. "Class IV: Preconfigured loads will arrive at BP 2 101000JUN92.</p>	
<p>a. General</p>	<p>a. General. Reference the SOPs that govern the sustainment operations of the unit. Provide current and proposed company trains locations, casualty and damaged equipment collection points, and routes to and from them.</p>	<p>"Company trains will be located at trail intersection in the vicinity of GL161823 after seizure of OBJ BULL.</p>	

Figure 2-2. Example of platoon operation order (continued).

FORMAT	ANNOTATED FORMAT	EXAMPLE, ORAL (ATTACK)	EXAMPLE, ORAL (DEFEND)
<p>b. Material and Services.</p> <p>(1) Supply.</p>	<p>b. Material and Services:</p> <p>(1) Supply. Include information on each class of supply—maps, water, special supplies, and captured enemy material. When applicable list constraints, and or limitations, specific operating hours, distribution methods or schedules and other information which alters the standard manner in which supplies are managed, controlled, handled, or distributed.</p>		
<p>(2) Transportation</p>	<p>(2) Transportation. Provide route limitations and traffic priorities by units, and schedule for services.</p>		
<p>(3) Services.</p>	<p>(3) Services. Include information or instructions that prescribe the type of service available, designation, and location of the facility and schedule for service.</p>		
<p>(4) Maintenance</p>	<p>(4) Maintenance. Include any information that differs from the established SOP on maintenance of weapons and equipment.</p>		
<p>(5) Medical Evacuation</p>	<p>(5) Medical Evacuation. Identify procedures for evacuation of wounded if they differ from the SOP:</p>	<p>“Evacuate casualties to the casualty collection point located behind the mounted element support position during the assault and behind the CP after the assault. Platoon CP after</p>	<p>“Casualty collection point is behind PSG’s position. The company has an M113 ambulance in support.”</p>

Figure 2-2. Example of platoon operation order (continued).

FORMAT	ANNOTATED FORMAT	EXAMPLE, ORAL (ATTACK)	EXAMPLE, ORAL (DEFEND)
	<p>seizure of OBJ CAT will be directly behind the BTR position.</p> <p>"Remains will be evacuated by LOGPAC to the GRREG collection point in the BSA. Contaminated remains will be separated and evacuated IAW guidance from the company commander.</p> <p>"Company expects to receive some replacements late on 15 June. We should receive two 11M10s. At that time, I will decide who will get them.</p> <p>"EPW collection point will be behind 1st Squad on the objective.</p>	<p>"PSG find and mark a route from the ambulance to get to us, as well as a litter evacuation route, if required, remains will be evacuated by LOGPAC vehicles to the GRREG point in the BSA.</p> <p>"Supply Sergeant, you are responsible for that. Contaminated remains will be separated and evacuated IAW further guidance.</p> <p>"The chaplain will hold a nondenominational service at the company CP at 2000 today. Squad leaders report the number of men wishing to attend to the PSG by 1400. PSG, get that information to the 1SG.</p>	
<p>d. Personnel.</p>	<p>d. Personnel. Identify the EPW collection point and any additional instructions on EPW handling not covered in the SOP.</p>		
<p>e. Miscellaneous</p>	<p>e. Miscellaneous. Include instructions for the destruction of supplies and any other information not covered elsewhere.</p>		
<p>5. COMMAND AND SIGNAL.</p>	<p>5. COMMAND AND SIGNAL.</p>	<p>COMMAND AND SIGNAL</p>	<p>COMMAND AND SIGNAL</p>
<p>a. Command</p>	<p>a. Command. Discuss the command structure if different than the SOP.</p>	<p>"SOI. Index 4-9 in effect.</p> <p>"Visual signals are as follows:</p> <p>"Two red star clusters: 2d Platoon</p>	<p>"The company CP is at GL112388. The company commander will be collocated with 2d Platoon.</p>

Figure 2-2. Example of platoon operation order (continued).

FORMAT	ANNOTATED FORMAT	EXAMPLE, ORAL (ATTACK)	EXAMPLE, ORAL (DEFEND)
	<p>(1) Location of the higher unit commander and command post.</p> <p>(2) Location on the higher unit during each significant phase of the operation, and the platoon command post.</p> <p>(3) Location of the platoon sergeant during each significant phase of the operation, and the location of the platoon alternate command post.</p> <p>b. Signal. Any special signals to be used during the battle by either the platoon internally or the company.</p> <p>(1) SOI index in effect.</p> <p>(2) Listening silence, if applicable.</p> <p>(3) Methods of communication in priority.</p> <p>(4) Emergency signals, visual signals.</p> <p>(5) Code words.</p>	<p>begins assault on OBJ CAT.</p> <p>"One red or one white star cluster: 3d Platoon is beginning assault on OBJ 2.</p> <p>"Chemical light will be used to mark progress on trench line clearing. GREEN = cleared portion. RED = obstacle or booby trap. INFRARED = lead element.</p> <p>"I will be the lead vehicle during movement to the assault position and occupy it with the dismounted element.</p>	<p>"I will be forward initially with the mounted element. After the engagement in EA PUP, I will position behind 1st Squad, in position number 2. The platoon CP will be located there also.</p> <p>"The platoon sergeant will remain with dismounted position while I am forward and will join his BFV in position 3 behind 2d Squad when it returns.</p> <p>"Current SOI is in effect.</p> <p>"Company cease fire signal is 2 green star clusters followed by 1 red.</p> <p>"One white star cluster will be an alternate signal for the mounted section to withdraw from BP 1.</p>

Figure 2-2. Example of platoon operation order (continued).

FORMAT	ANNOTATED FORMAT	EXAMPLE, ORAL (ATTACK)	EXAMPLE, ORAL (DEFEND)
		<p>"The time is now 1007. What are your questions?"</p>	<p>"Code words for execution of EA PUP is LIGHTNING BOLT, EA FOX is GOLDSTRIKE; for all platoon weapons to fire in EA FOX is SMASH. "The running password for patrols is MOOSEBREATH, followed by the number of soldiers returning. "The time is now 0912. What are your questions?"</p>

Figure 2-2. Example of platoon operation order (continued).

b. The leader uses a fragmentary order (FRAGO) to change an existing order. He normally uses the OPORD format but addresses only those elements that have changed. The leader should make his instructions brief, simple, clear, and specific.

c. Annexes provide the instructions for conducting specific operations such as air assault, boat, and truck movement, stream crossings, establishing patrol bases, and airborne insertions, if they are so detailed that a platoon SOP is insufficient for a particular situation. The format is the same as the five-paragraph OPORD.

d. An operation overlay is a tracing of graphic control measures on a map. It shows boundaries, unit positions, routes, objectives, and other control measures. It helps to clarify the operation order. Platoons normally trace their overlays from the company operations map. Squad leaders transfer control measures on to their maps as needed. The subordinate's need for higher unit graphics must be balanced against the risk of the enemy obtaining this information. An example company operation overlay for an attack is in Figure 2-3, page 2-32. An example company operation overlay for a defense is in Figure 2-4, page 2-33. An example platoon overlay for a defense is in Figure 2-5, page 2-34.

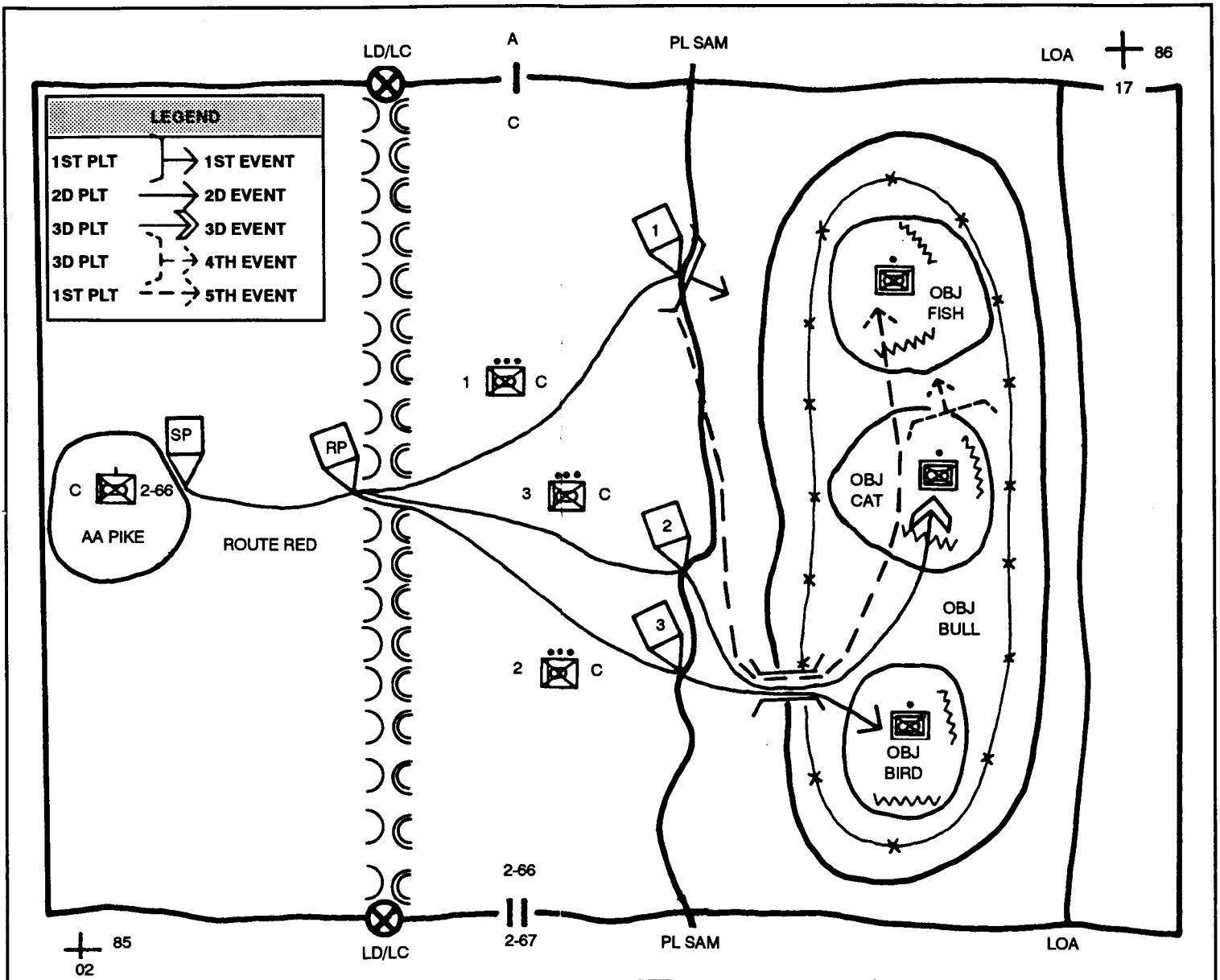

Figure 2-3. Example a company overlay (attack).

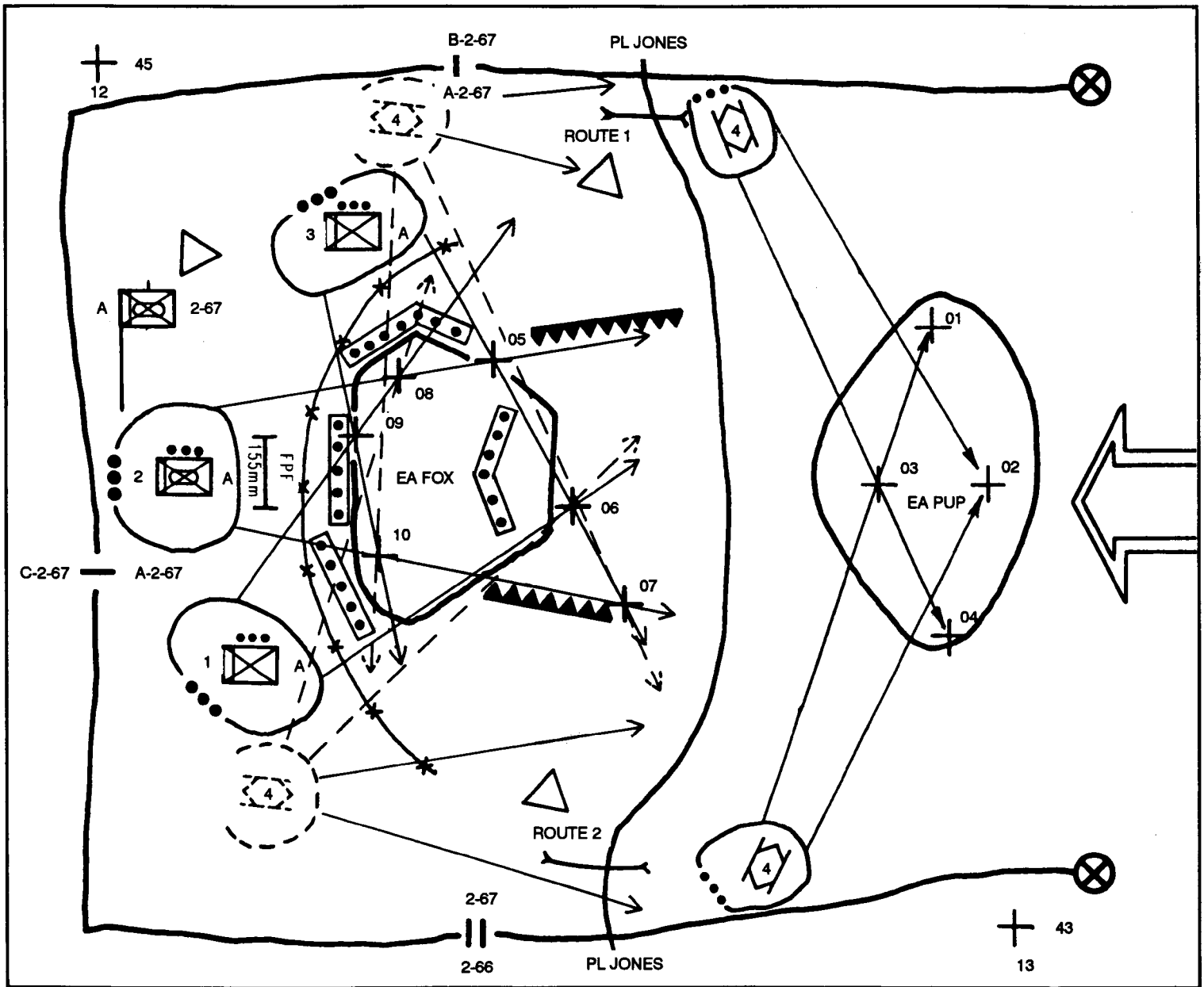

Figure 2-4. Example of a company overlay (defend)

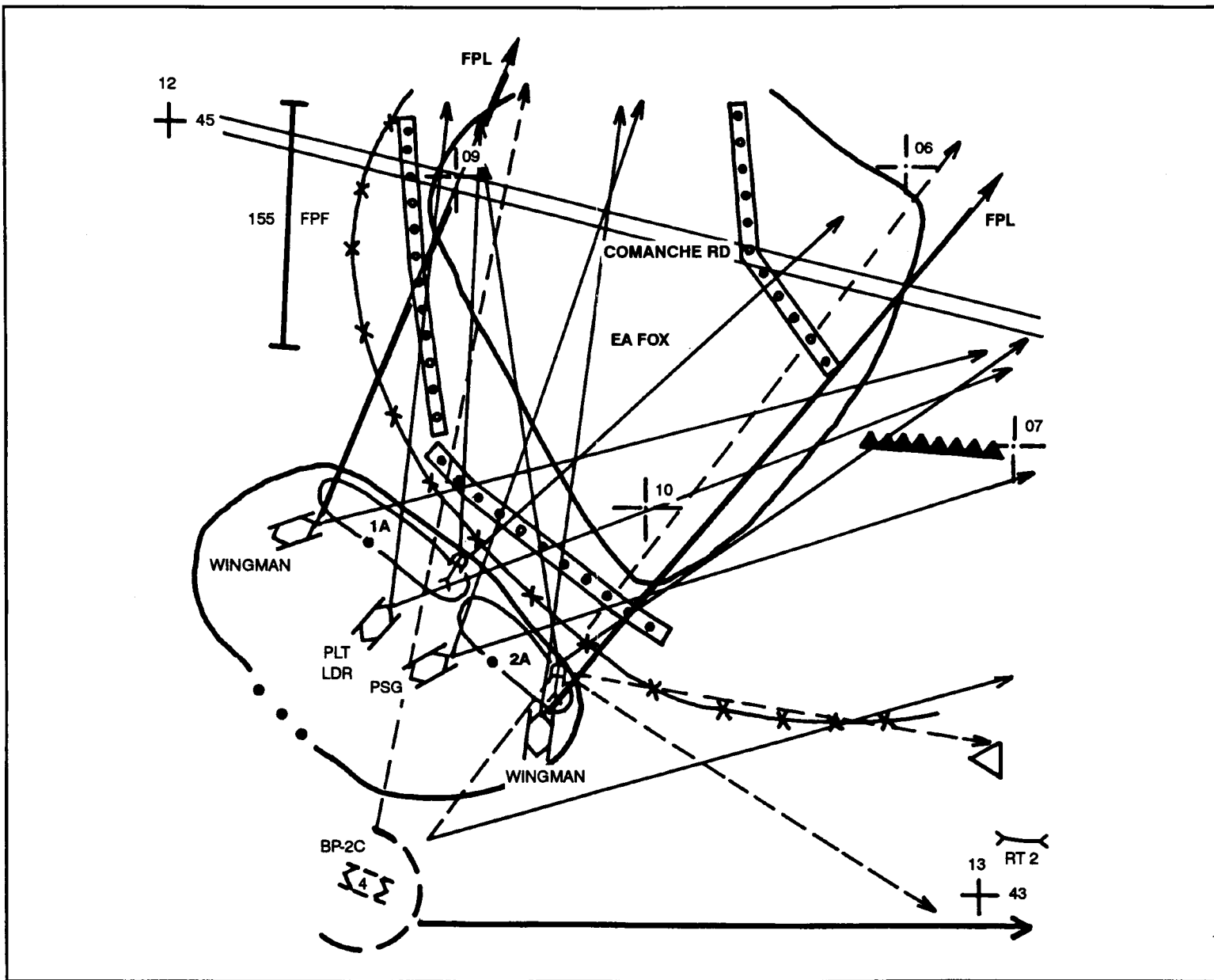

Figure 2-5. Example of a platoon overlay (defend).

e. When possible, the leader uses the actual terrain or a terrain model to brief his OPORD. He may also use concept sketches—large, rough drawings of the objective areas—to show the flow of events and actions clearly.

(1) **Concept sketch.** A concept sketch should include the task and purpose. The sketch shows the locations and positions of objectives, control measures, and key terrain in relation to each other. It is not necessarily drawn to scale. Example battalion, company, and platoon concept sketches are in Figures 2-6, 2-7, 2-8, and 2-9, pages 2-36 through 2-39.

(2) **Terrain model.** A terrain model is a three-dimensional scale model of the terrain (Figure 2-10, page 2-39). It is effective for briefing and discussing the actions on the objective. It may depict the entire mission area. However, for offense missions, priority should be given to building a model of the objective area.

(a) It should be built oriented to the ground (north on the model is north on the ground) and should show the main terrain features in the area.

(b) The next step after orienting the model to the ground is the construction of grid squares. The leader should identify the grid squares that the model will show. These ensure a more accurate model.

(c) The terrain model should depict key terrain, friendly control measures, and enemy dispositions.

(d) Materiel for constructing the model includes string, yarn (various colors), chalk (colored), 3x5 cards, target markers, or unit markers.

- MISSION: B Co.
TASK: Suppress enemy on OBJ DOG.
PURPOSE: Allow Co A to seize OBJ DOG.
- MISSION: Team A.
TASK: Destroy enemy on OBJ DOG.
PURPOSE: Deny enemy Box Springs Road.
- MISSION: C Co.
TASK: Seize OBJ BULL.
PURPOSE: Prevent enemy from counterattacking against Co A.
- MISSION: Reconnaissance Plt.
TASK: Screen Bn left flank.
PURPOSE: To prevent BN from being enveloped from the left.
- MISSION: E Co.
TASK: Suppress enemy on OBJ BULL and be prepared to fire to protect the BN flank from counterattack.
PURPOSE: To allow Co C to seize OBJ BULL and protect BN right flank.
- MISSION: Mortar Plt.
TASK: Provide indirect fires to support BN attack.
PURPOSE: To allow the BN to seize OBJ DOG and OBJ BULL.
- MISSION: Team Tank.
TASK: On order be prepared to follow and support A Co.
PURPOSE: To provide flexibility to BN scheme of maneuver and ensure security of BN mission.

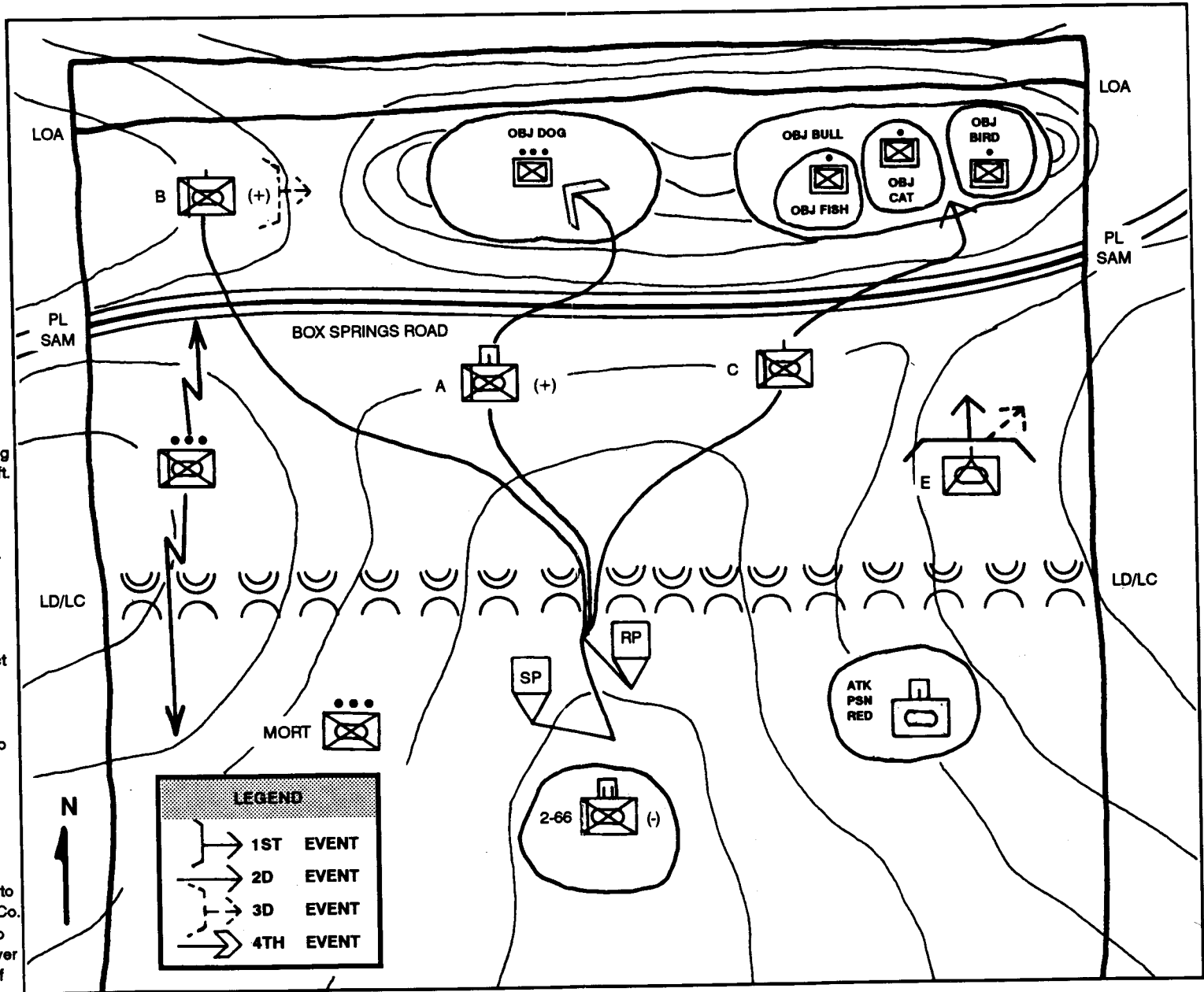

Figure 2-6. 2-66 Infantry (Mech) concept sketch.

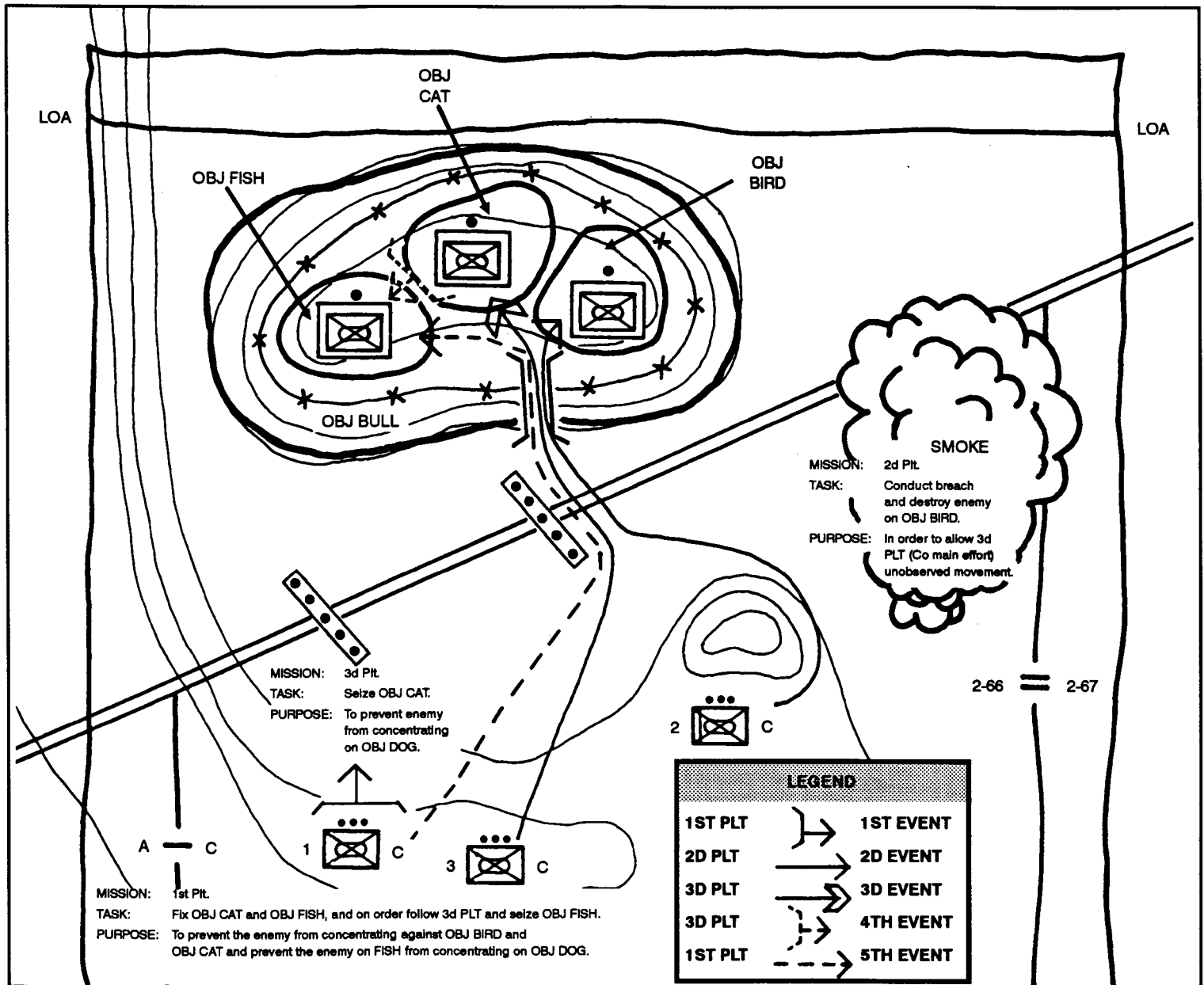

Figure 2-7. C/2-66 Infantry (Mech) concept sketch.

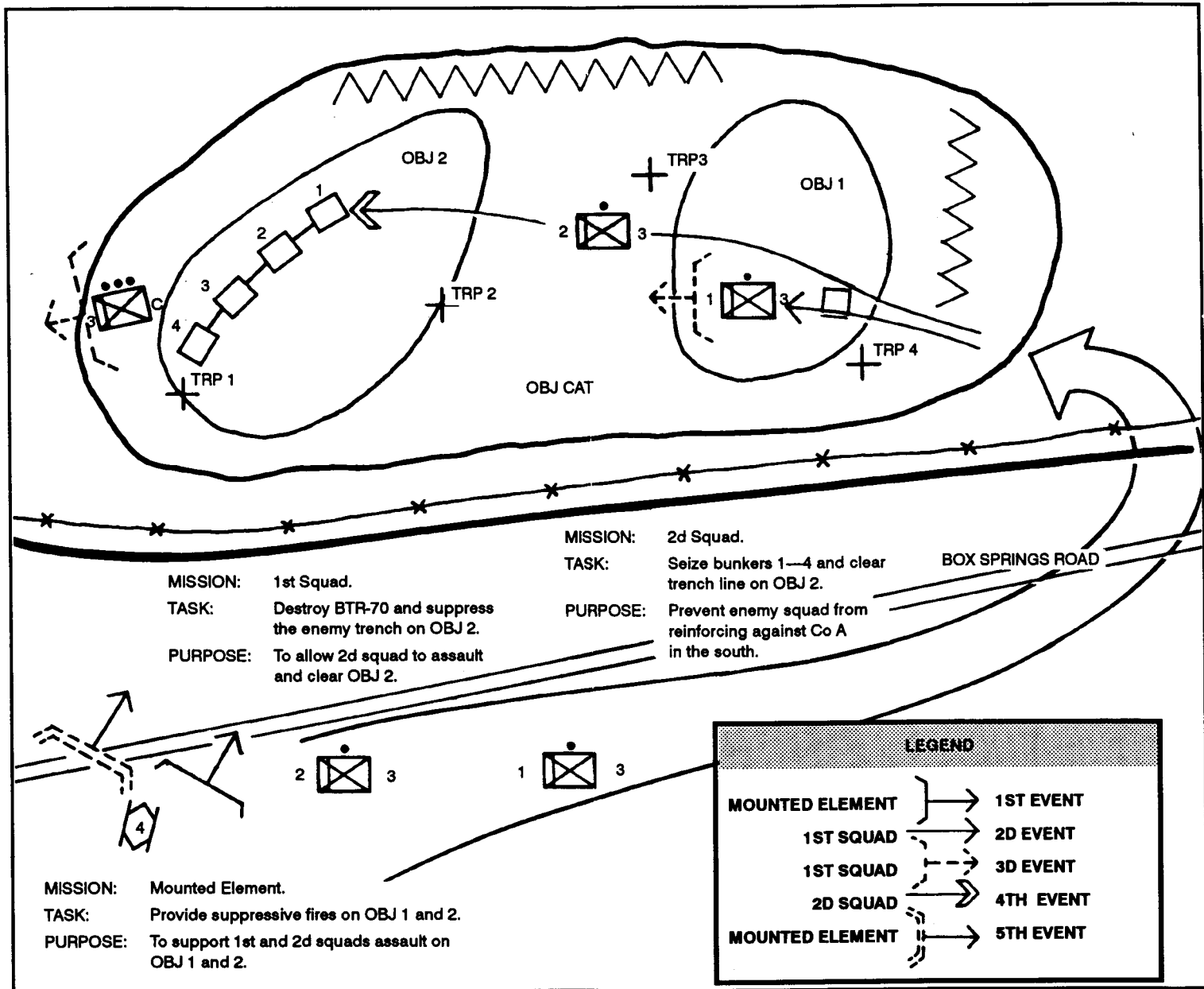

Figure 2-8. 3/C/2-66 Infantry (Mech) concept sketch.

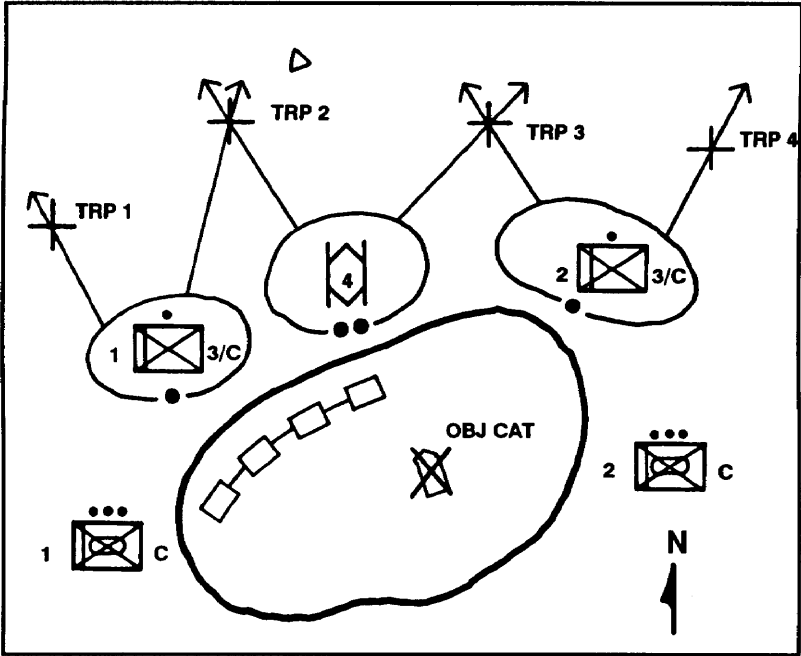

Figure 2-9. 3/C/2-66 Infantry (Mech) consolidation plan concept sketch.

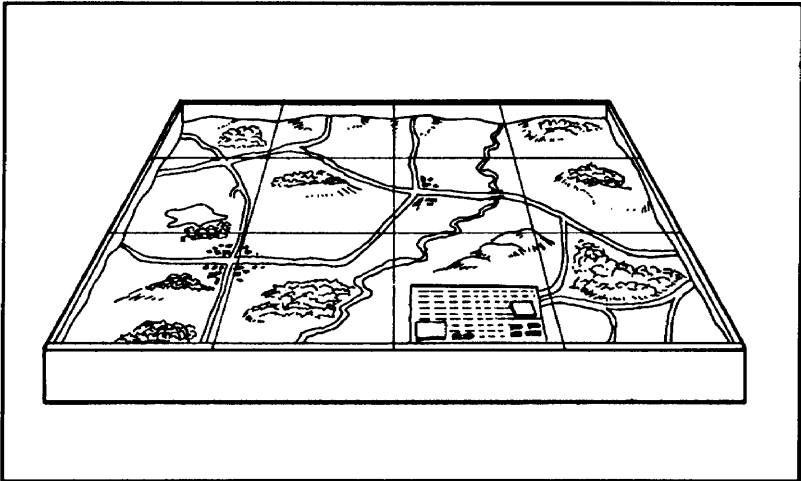

Figure 2-10. Terrain model.

2-4. FIRE CONTROL AND DISTRIBUTION

As a member of the combined arms team, the BFV platoon must provide sufficient dismounted infantry during combat operations and during all battlefield conditions. BFV crews provide direct-fire support to the maneuvering dismounted infantry. Effective fire control and distribution measures must be established to avoid fratricide and allow the infantry to gain and maintain the initiative. Platoons must establish clear fire control and distribution SOPs and practice them during all aspects of training. Crews must be well disciplined in these techniques and should be aware that the infantry can dismount and join the battle at anytime. Squad and team leaders must remain alert and aware of the tactical situation while riding in the troop compartment. They must be prepared to execute the command to dismount quickly. Once on the ground, the infantry must remain aware of the vehicle element's location and establish measures to keep BCs aware of the squad's location. Leaders must know principles of fire control, methods of fire control and distribution, and methods of engaging targets with antiarmor weapons.

a. The principles of fire control areas follows.

(1) ***Destroy the most dangerous targets first.*** The danger an enemy vehicle or weapon system presents to the squad or platoon changes with range, terrain, and the weapons mounted on the vehicle. Generally, tanks present the greatest threat to BFVs at ranges out to 2,000 meters. However, Soviet tanks equipped with missiles can engage BFVs up to 4 kilometers away. At ranges greater than 2,000 meters, a BRDM or a BMP firing an ATGM presents a greater threat. A BMP that is moving does not present a meaningful threat until it moves within 1,000 meters. An RPG team is a threat within 300 meters. Targets are engaged in direct relation to the danger they present. If two or more targets are equal threats, the closest one should be engaged first.

(2) ***Avoid target overkill.*** A force fighting outnumbered cannot afford to engage a single target with more than one weapon. Bradley commanders strive for single engagements and one-shot kills with the TOW, and single-round ranging shots and short-burst kills with the 25-mm gun. Bradley commanders must avoid engaging disabled vehicles. Such targets should be left for tanks or other weapon systems with a larger basic load of ammunition and more destructive power or engaged after other, more dangerous targets have been destroyed.

(3) ***Concentrate on long-range targets.*** The fire team weapons also complement the BFV's weapons. The machine guns, rifles, grenade launcher, AT4, and Dragon are best used along more restrictive

approaches where fields of fire are limited. This allows the BFV to concentrate on long-range targets.

(4) **Control fires to achieve the best shots and expose only those BFVs needed for an engagement.** The leader uses the BFV that has the best chance of engaging and destroying the enemy. All other vehicles should remain hidden until additional targets are within the engagement area, the firing BFV needs help in destroying the target, or they are needed to provide cover for withdrawal action.

(a) Flank shots offer the best opportunity to destroy enemy targets. Threat armor is more penetrable on the flanks and in the rear than in the front.

(b) The platoon engages only targets that offer a high-probability of a hit. Engagements beyond the effective range of the weapon system are avoided. Trigger lines and or the laser range finder are used to determine the maximum engagement lines. Exposing BFV firing positions and wasting ammunition are avoided.

(5) **Use each weapon in its best role.** Each BFV weapon has its own capabilities and limitations. Each is used in roles for which it is best suited and how it best complements the other weapons.

(a) The 25-mm gun is best used to destroy lightly armored or unarmored vehicles and to suppress antitank guided missiles at medium to long range. Each BFV carries 900 rounds of 25-mm ammunition consisting of AP and HE rounds. Three hundred rounds are uploaded and 600 rounds are stored in the rear of the vehicle.

(b) For stand-off protection, the TOW is best used against armored targets 2,000 meters and beyond. The TOW is mainly used to engage tanks that cannot be destroyed with the 25-mm gun. Each BFV can carry up to seven TOW missiles; two missiles in the launcher and five stowed inside the BFV (The five missiles inside can be any combination of TOWS or Dragons.)

(c) The 7.62-mm coaxial machine gun is best used to destroy unarmored vehicles, kill dismounted infantry, and suppress enemy gunners out to 1,000 meters. It is used against suitable targets to complement the 25-mm gun at shorter ranges. This helps conserve the 25-mm ammunition.

(d) The dismounted squads use the machine gun, antiarmor weapons, and automatic rifles to close with and destroy the enemy.

(6) **Maintain combat loads as long as possible.** Ammunition resupply is a major problem on the battlefield. Without proper fire discipline, a BFV can use its entire combat load in one or two engagements and then

be ineffective in later encounters. Crews must constantly check the on-board supply of ammunition. Ammunition reporting procedures should be established as SOP. The platoon leader should prescribe how low on ammunition the platoon, sections, or squads can get before requesting resupply. Elements should not be allowed to drop below this level except in a combat emergency. To reduce reloading time, ammunition in the ready racks is replaced at every chance.

(7) **Avoid fratricide.** When possible, crews avoid engagements that are close to friendly infantry or vehicles. BFV crews must remain aware of the movement of the dismounted element to avoid casualties from friendly fires. Additionally, infantry squads must establish measures to keep the BFV crews aware of their location.

b. When moving, a section or platoon uses offensive engagement techniques when stationary, they use defensive techniques regardless of the mission.

(1) **Individual BFVs.** Threat armored vehicles have more armor in the front 60-degree arc of the vehicle than on the flanks and rear portions. Thus, the leaders must understand fighting positions' effectiveness against the Threat (for example, flank shots and close combat techniques).

(2) **Section/wingman concept.** A Bradley section consists of the platoon leader and a wingman or platoon sergeant and a wingman. The wingman concept helps in the command and control of the platoon. Platoon/section SOPs dictate the engagement and firing techniques to be used by sections. Whether the sections fire together or alternate fires, mutual support is provided. Sections always operate as part of a platoon.

(3) **Squads.** The dismount element consists of two 9-man squads with two squad leaders and four fire team leaders. The platoon leader normally operates on the ground with the dismounted squads.

(4) **Platoons.** In mechanized infantry forces, the Bradley platoon is the lowest level employed to conduct operations.

c. Fire control and distribution procedures provide leaders with a method to achieve their objective. Proper use of fire control and distribution ensures a unity of effort and the ability to mass the effects of combat power at the decisive place and time. Leaders must decide which fire control method or combination of methods will work in each tactical situation. They must ensure the fires of their platoons are effective.

(1) **Methods of fire control.** The methods of fire control are sound signals, graphic control measures, visual signals, and time.

(a) **Sound signals.** This includes both voice and devices such as whistles and horns. Sound signals are good only for short distances.

Their range and reliability are reduced by battle noise, weather, terrain, and vegetation.

(b) *Graphic control measures.* These measures must be simple and clear. Above all they must support the concept of the operation. Routine use of standard control measures will ensure understanding and compliance at the lowest level. Listed below are some of the key control measures used by mechanized infantry platoons.

- Sector of fire. FM 101-5-1 defines a sector of fire as “an area that is required to be covered by the fire of an individual weapon, or a unit.” The primary purpose of sectors of fire is to ensure distribution of fires across a platoon’s area of responsibility. The leader may use sectors of fire to divide the engagement area among his principle weapons (Figure 2-11).

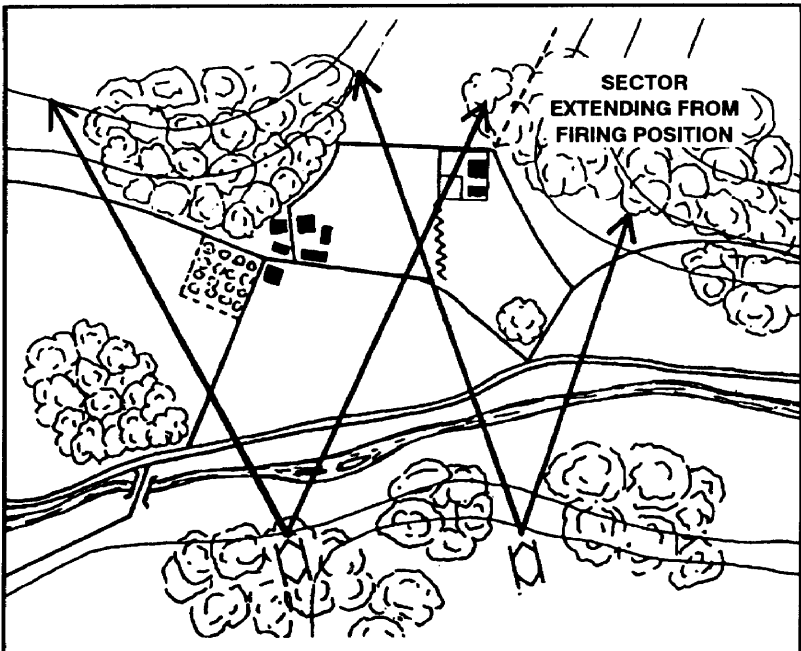

Figure 2-11. Sector of fire.

- Engagement areas. FM 101-5-1 describes an engagement area as “an area in which the commander intends to trap and destroy an enemy force with the massed fires of all available weapons.” As a

control measure, the engagement area attempts to concentrate the fires of a unit against enemy forces. Engagement areas can be divided into sectors of fire for subordinate units or weapons systems or both.

- Target reference point. A TRP is an easily recognizable point on the ground (either natural or man-made) used for identifying enemy targets or controlling fires (Figure 2-12).

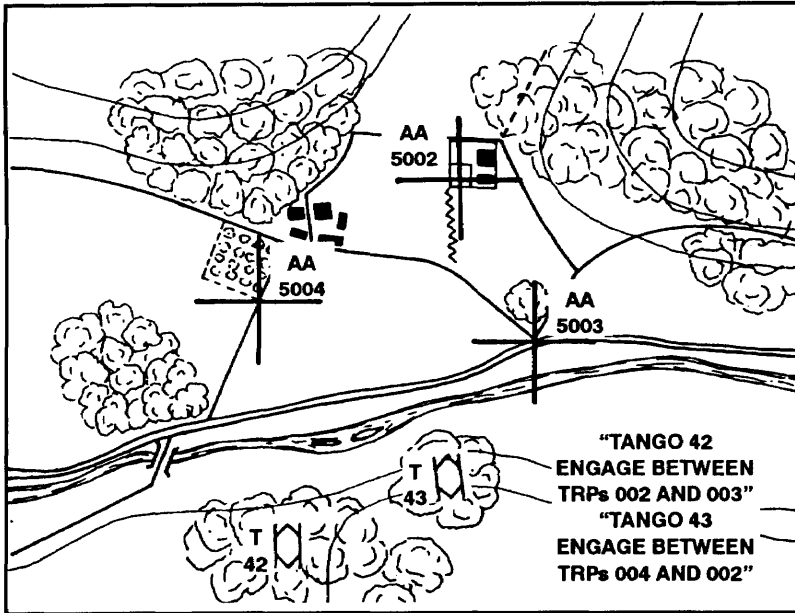

Figure 2-12. Target reference points.

- Phase lines. A phase line is a linear control measure normally used to control movement. It can also be used to control and distribute the fire of sections and squads. Any prominent natural or man-made linear terrain feature—for example, a ridge line, river or stream, road, or railroad track—can be used as a phase line. (Figure 2-13.)

(c) *Other graphic control measures.* The following graphic control measures also aid in the control but to a lesser degree than the previous listed graphic control measures. These control measures are used for both day and limited visibility. However, some adjustments may have to be made.

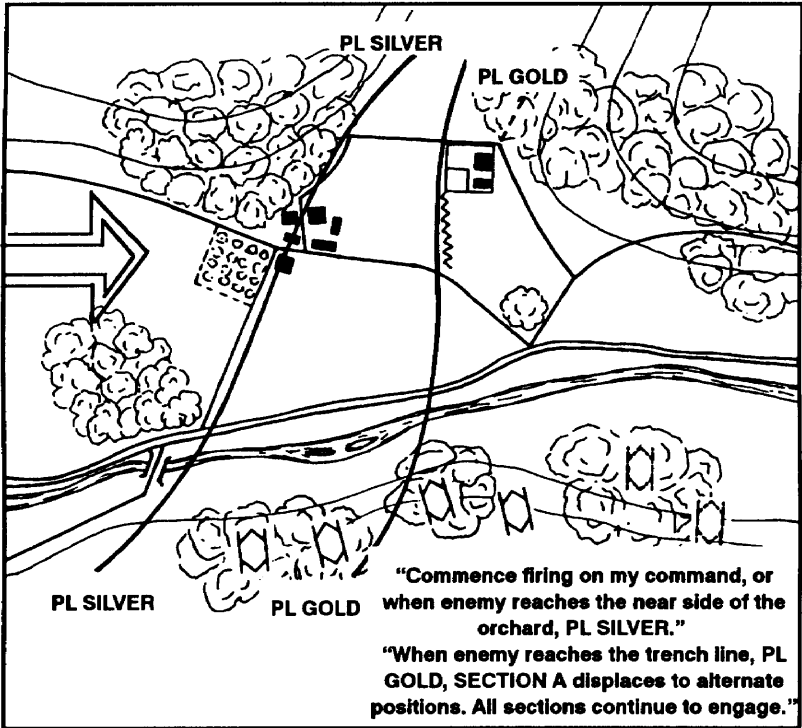

Figure 2-13. Phase line.

- **Attack position.** It is the last position occupied or passed through by the assault echelon before crossing the LD. It provides cover and concealment, and permits easy entry and exit. It is used to ensure coordinated effort by the entire force. It may or may not be used. During limited visibility, it may be closer to the LD and smaller than during good visibility.
- **Line of departure.** An LD is designated to coordinate the commitment of attacking units at a specified time.
- **Point of departure.** Because it is critical all movements be closely coordinated; squads, section, or platoon may be assigned a specific point to cross the LD.
- **Release point.** Each company commander releases control of his platoons to the platoon leaders at the company RP. RPs are far enough from the objective to allow units to deploy before they reach the probable line of deployment.

- **Route.** The company commander normally picks the routes from the company RP to platoon RPs. Platoon leaders pick routes from platoon RPs to the squad RPs.
- **Probable line of deployment.** The company commander may designate a PLD. This is the place he deploys his unit before beginning the assault. A PLD is normally used during limited visibility.
- **Objectives.** The company commander assigns each platoon an objective, which is part of the company objective. These are easy-to-identify terrain features.
- **Limit of advance.** To keep friendly supporting fires from falling on friendly dismounted troops, leaders may designate a limit of advance. It should be a terrain feature easy to recognize during limited visibility. Assaulting elements do not advance beyond this feature. This allows supporting fires beyond the objective without endangering friendly troops.
- **Battle positions.** The company commander assigns each platoon a defensive location oriented on the most likely enemy avenue of approach from which a unit may defend or attack.

(d) *Visual signals.* The leader can give a visual signal when he wants the soldiers to begin, cease, or shift fire as soon as they see the signal. Platoons can also use visual signals triggered by the enemy.

(e) *Time.* Units may be directed to begin, shift, and cease firing at a set time.

(2) **Fire commands.** Leaders use fire commands to direct the fires of the unit. A fire command has the following six elements.

(a) *Alert.* The first element alerts the crew of an immediate engagement and who will conduct the engagement.

(b) *Weapon/ammunition.* The second element informs the crew of the weapon and/or ammunition that is to be used.

(c) *Description.* The third element identifies the target for the crew. If there are multiple targets, the BC tells the crew which target to engage first.

(d) *Direction.* The fourth element is given to guide the gunner when the BC cannot lay the weapon for direction or elevation.

(e) *Range.* The fifth element of a fire command is used when the BC chooses the precision gunner method. (See FM 23-1, Chapter 3, Section II.)

(f) *Execution.* Once the crew responds to the first five elements, the BC gives the execution element. Before the execution element, the BC reconfirms the target as hostile.

(3) **Methods of fire distribution.** Leaders must distribute the fires of their organic weapons to destroy or suppress enemy positions. There are two ways to distribute fire on a target—point fire and area fire.

(a) **Point fire.** Point fire is directed against a specific identified target, such as a machine gun or ATGM position. All weapons are fired at the target. Spreading out the platoon on the ground aids in point fire, because the target is hit from multiple directions. Point fire is not often used, because the platoon seldom encounters a single, clearly identified enemy weapon. (Figure 2-14.)

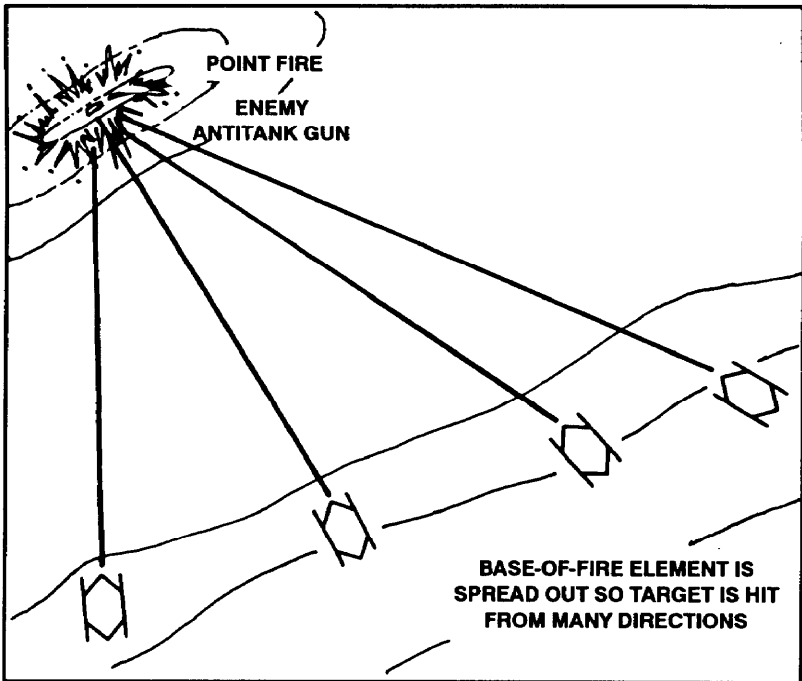

Figure 2-14. Point fire.

(b) **Area Fire.** Area fire is distributed over a larger area when enemy positions are numerous or less obvious. Each weapon or BFV in the defense or overwatch element is given a specific sector of the target area to fire into. This is done to ensure that the entire target area is covered by fire and observation. (Figure 2-15, page 2-48.)

(4) **Fire patterns.** The three basic fire patterns are frontal fire, cross fire, and depth fire. They are used to distribute the platoon's fire when

multiple targets appear and no other measures have been assigned or in conjunction with other measures.

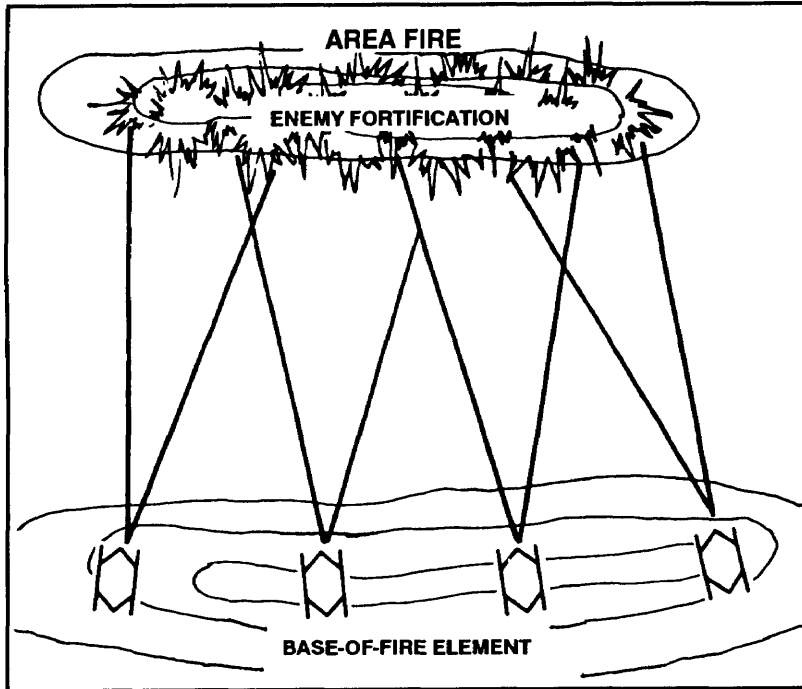

Figure 2-15. Area fire.

(a) *Frontal fire.* Frontal fire is used when targets are dispersed laterally to the platoon's direction of fire. Each weapon shoots targets to its front, with flank weapons engaging flank targets first. As targets are destroyed, fire is shifted toward the center of the target area (Figure 2-16).

(b) *Cross fire.* Cross fire is used when targets are dispersed laterally but obstructions prevent all weapons from firing to the front (Figure 2-17). Cross fire is also used to get flank shots. Flank shots increase the chance of a kill and avoid detection when the enemy is moving straight at the BFV. Each weapon engages a target diagonal to its position, with flank weapons engaging targets on the opposite flank. As targets are destroyed, fire is shifted to the center of the enemy formation.

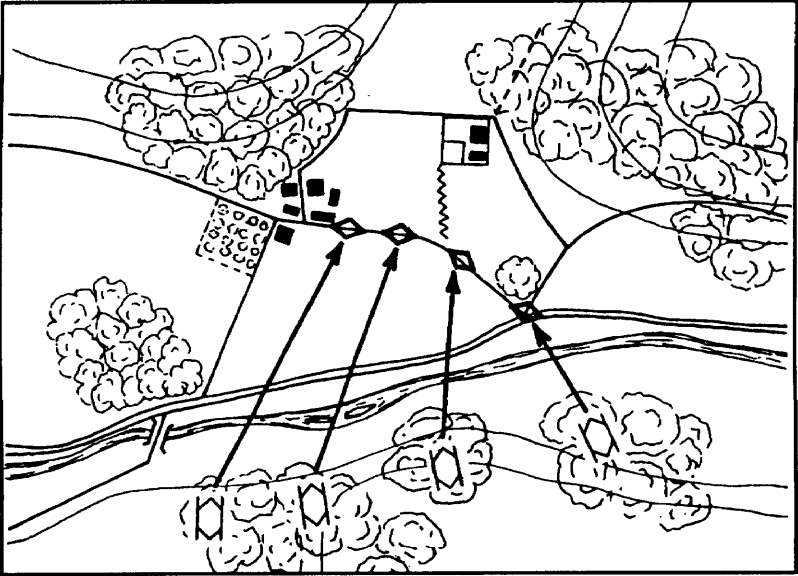

Figure 2-16. Frontal fire.

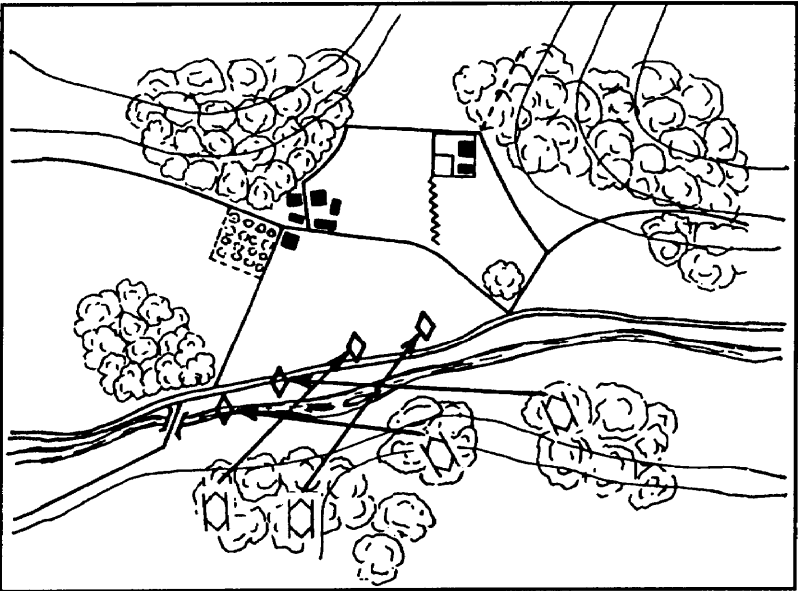

Figure 2-17. Cross fire.

(c) *Depth Fire.* Depth fire is used when targets are exposed in depth (Figure 2-18). Weapons on one side engage the nearest targets, while weapons on the other side engage the farthest targets. Fire is then shifted toward the center of the formation. This is done by platoon SOP or as specified in the leader's order.

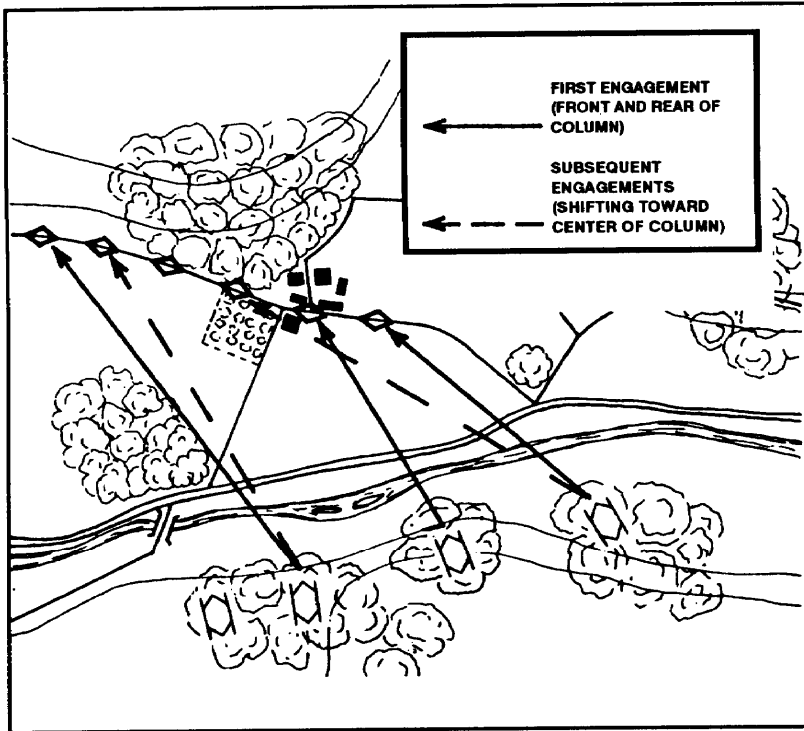

Figure 2-18. Depth fire.

(d) *Change in fire pattern.* Fire patterns are changed or used concurrently with other fire patterns when necessary to ensure maximum coverage of an enemy formation. This may be necessary when the enemy, after being engaged, adjusts his formation (Figure 2-19).

d. Methods of employment for antiarmor weapons areas follows.

(1) **Dragon.** There are two options for the employment of Dragons in the mechanized infantry platoon— centralized or decentralized.

(a) *Centralized control.* The platoon leader controls the fires of his Dragon gunners, either by locating the weapons near him and personally

directing their fires, or by grouping them together under the control of the platoon sergeant or another individual the platoon leader designates.

(b) *Decentralized control.* Dragon gunners operate with, and are controlled by their squad leaders. It may be necessary for the squad leader to employ one fire team as a Dragon team. The platoon leader normally gives the command for opening fire.

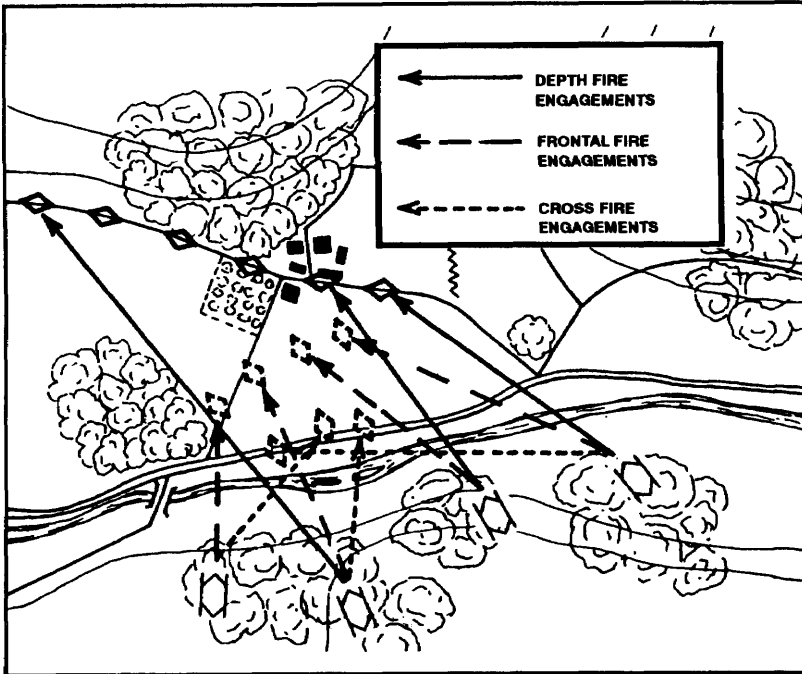

Figure 2-19. Change fire patterns.

(c) *Target engagement.* Target priorities and rules of engagement may change from situation to situation. Leaders must specify to Dragon gunners, either in their plans and orders, or by platoon SOP, target priorities and rules for engaging multiple targets. Dragon gunners should be assigned sectors of fire to preclude more than one weapon engaging the same target simultaneously. When engaging targets, gunners ensure they can track the target until impact.

(d) *Oblique fire.* Whenever possible, gunners engage targets with oblique fire. Platoon and squad leaders, when selecting positions, make every effort to emplace the gunner in a position that permits him to cover his sector

with oblique fire. It is difficult for the enemy to retrace the flight path of a missile to its launch site when the missile moves obliquely across their front, as opposed to being launched from a head-on position. Forces generally orient to their front, and are therefore more vulnerable to fires from their flanks.

(2) **LAW and AT4.** The four methods of engaging targets with both the LAW and the AT4 are single, sequence, pair, and volley firing.

(a) *Single firing.* In single firing, one soldier engages a target with one LAW or AT4—there are no follow-on shots. This method is mostly for use at short ranges (50 meters or less with the LAW; 200 meters or less with the AT4). The single-firing method can be effective at greater ranges (out to 200 meters with the LAW, out to 300 meters with the AT4) when the exact range to the target is known.

(b) *Sequence firing.* In sequence firing, one firer armed with two or more LAWS or AT4s engages a single target. The firer—

- Inspects and prepares the weapons for firing and lays them side by side.
- Fires and observes the impact of the round.
- If he hits the target, continues to fire follow-on rounds until the target is destroyed or until ordered to cease fire.
- If he misses, applies burst-on-target corrections with follow-on rounds until the target is hit. He then fires until he destroys the target or until ordered to cease fire.

(c) *Pair firing.* In pair firing, two or more firers each armed with two or more LAWS or AT4s engage the same target. They exchange information throughout the target engagement.

- The first firer who sees the target identifies it, announces the estimated range and the lead he will use, and fires.
- The second firer observes the firing, announces a revised estimate of range and lead (if appropriate), and fires.
- The firers continue exchanging range and lead information until the target is hit.
- Once the range and lead have been determined, both firers, on command, engage the target until it is destroyed or until ordered to cease fire.

(d) *Volley firing.* In volley firing, more than one firer engages the same target using one or more LAWS and AT4s. Volley firing should be used when the range to the target has been determined. This method is desirable because more rounds are fired at a given time, thus increasing the probability of hitting/killing the target (FM 23-33 and FM 23-25).

Section II SECURITY

This section discusses techniques used by mechanized infantry platoons and squads to provide security for themselves and for larger formations during movements and offensive and defensive operations. Security is part of force protection which enhances the combat power of the force. Positioning of thermal sights during movement, offense, and defense is critical to security. Platoon leaders must ensure the use of thermal sights is included in their security plan.

2-5. SECURITY DURING MOVEMENT

Security during movement includes the actions that platoons and squads take to secure themselves and the tasks given to them to provide security for a larger force.

a. Platoons and squads enhance their own security during movement through the use of covered and concealed terrain; the use of the appropriate movement formation and technique; the actions taken to secure danger areas during crossing the enforcement of noise, light, and radiotelephone discipline; and the use of proper equipment and individual camouflage techniques. Platoons also enhance their security by using the correct graphic control measures, formations, and movement techniques to prevent fratricide.

(1) **Terrain.** In planning a movement, leaders consider the terrain from the aspect OAKOC as discussed in Section I. Leaders look for terrain that avoids obstacles, provides protection from direct and indirect fires and from ground and aerial observation, avoids key terrain that maybe occupied by the enemy, allows freedom to maneuver, and avoids natural lines of drift or obvious terrain features. If key terrain cannot be avoided, leaders plan to reconnoiter it before moving through. When operating as an advance or flank guard for a larger force, platoons and squads maybe tasked to occupy key terrain for a short time while the main body bypasses it.

(2) **Formations and movement techniques.** Formations and movement techniques provide security by—

- Positioning each vehicle and soldier so that they can observe and fire into a specific sector that overlaps with other sectors.
- Placing a team or section forward to allow the platoon to make contact with only the lead team and give the remainder of the platoon freedom to maneuver.
- Providing overwatch for a portion of the platoon.

In selecting formations and movement techniques, leaders must consider other requirements such as speed and control as well as security. See Section III for information on determining the best formation and technique based on METT-T

(3) **Security at danger areas.** Paragraph 2-10 describes actions taken by platoons and squads to secure danger areas before crossing them.

(4) **Camouflage, noise, light, litter and radiotelephone discipline.** Leaders must ensure that camouflage used by their platoon is appropriate to the terrain and season. Platoon SOPs specify elements of noise, light, litter, and radiotelephone discipline. (See Chapter 4.)

b. Platoons, sections, and squads may operate as the advance, flank, or rear guard for larger units. They employ the same techniques described above to move as securely as possible.

c. During short halts, vehicles deploy into a herringbone or coil formation for all-round security and soldiers dismount and assume prone positions behind cover. They watch the same sectors that were assigned to them for the movement. Leaders establish OPs, and orient machine guns and vehicle weapon systems along likely enemy approaches. Soldiers remain alert and keep movement to a minimum. During limited visibility, leaders incorporate the use of night vision devices.

d. During long halts, the platoon establishes a perimeter defense (See Section V). The platoon leader ensures that the platoon halts on defensible terrain. He establishes the defense using the same considerations discussed in Section V.

e. For additional security during halts, the platoon leader may establish a section- or squad-sized ambush. He must provide a specific location and instructions concerning the initiation and conduct of the ambush and the linkup of the section or squad with the platoon.

2-6. SECURITY IN THE OFFENSE

Security in the offense includes actions taken by platoons, sections, and squads to find the enemy, to avoid detection or prevent the detection of the larger body, and to protect the platoons, sections, or squads during the assault on the objective. Fratricide prevention is also an integral part of security in the offense and must be integrated into offensive planning.

a. **Movement to Contact.** Platoons and squads execute guard or screening missions as part of a larger force in a movement to contact.

b. **Reconnaissance Patrols.** Platoons and squads conduct reconnaissance patrols before executing offensive operations to find the enemy and determine his strength and dispositions.

c. **Hasty and Deliberate Attacks.** Platoons and squads use the same security techniques for movement discussed above while moving from assembly areas to the objective. The base-of-fire and maneuver elements of the platoon must provide their own security while executing their specific tasks.

(1) **Base-of-fire element.** The platoon sergeant or leader controlling the base-of-fire element should designate vehicles and soldiers on the flanks of the position to provide observation and, if necessary, fires to the flanks while the element engages the enemy on the objective. The base-of-fire element also provides security to its rear.

(2) **Maneuver element.** The maneuver element must secure its own flanks and rear as it assaults the objective. Platoon leaders should consider designating assaulting sections and buddy teams to observe the flanks and rear. When clearing trenches, the platoon should be alert against local counterattacks along cleared portions of the trench behind the lead fire team. The base-of-fire element provides security for the maneuver element by engaging any counterattacking or reinforcing forces if it can do so without endangering the maneuver element with its own fires.

d. **Consolidation.** Platoons and squads move quickly to establish security during the consolidation of an objective. They do this by establishing OPs along likely approaches and by establishing overlapping sectors of fire to create all-round security. (See Section V.)

2-7. SECURITY IN THE DEFENSE

Security in the defense includes active and passive measures taken to avoid detection or deceive the enemy and to deny enemy reconnaissance elements accurate information on friendly positions. Fratricide prevention is also an integral part of security in the defense and must be integrated into defensive planning.

a. **Terrain.** Leaders consider the terrain in terms of OAKOC as they plan for security in the defense. They look for terrain that will protect them from enemy observation and fires and, at the same time, provide observation and fires into the area where they intend to destroy the enemy or defeat his attack. When necessary, leaders use defensive techniques, such as reverse slope or perimeter defense, to improve the security of the defensive position. Leaders plan protective obstacles to the flanks and rear of their positions and tie them in with supplementary fires. Leaders consider adjacent key terrain that threatens the security of their positions. They secure this terrain by posting OPs and by covering it with direct and indirect fires. Finally, leaders establish OPs along the most likely enemy approaches into the position or sector to provide early warning.

b. **Observation Posts.** Each platoon should post at least one OP. The platoon leader designates the general location for the OP and the routes to and from the OP. The squad leader establishing the OP selects the specific site. Section XII provides a detailed discussion of the techniques used by platoons and squads in establishing and manning OPs. When a platoon performs a screen mission for a larger force in a defense, it may establish squad-sized OPs that are well dispersed. The squads conduct patrolling missions between these OPs to establish the screen.

c. **Patrols.** Platoons should actively patrol the area to their front and flanks while in a defensive operation. These patrols should include observation of dead space, gaps between platoons and companies, open flanks, and gaps or lanes in tactical and protective wire. Patrols may also be used to establish and relieve OPs. On completion of a patrol mission, the patrol members are debriefed and the information disseminated throughout the platoon. The platoon leader must ensure that all patrols not initiated by his higher headquarters are coordinated with them. (See FM 7-8 for additional information.)

d. **Passive Measures.** Platoons may be directed to cover specific areas of its sector with night vision devices, thermal sights, or early warning devices. These systems should be incorporated into the platoon sector sketch. Passive measures also include camouflage; movement control; and noise, light, litter, and radiotelephone discipline.

e. **Deceptive Measures.** Deceptive measures include actions that platoons and squads may take to mislead the enemy and induce him to do something counter to his interests. Platoons may employ deceptive measures for local security such as dummy positions or supplemental wire.

f. **Deception Operations.** Platoons may conduct deception operations as part of a larger force. These operations may include demonstrations, feints, displays, or ruses. In most instances platoons execute missions as normal but on a limited scale (feint), or to present a false picture to the enemy.

Section III MOVEMENT

This section discusses formations, movement techniques, and actions during mounted and dismounted movement for mechanized infantry platoons and squads.

2-8. FORMATIONS

Formations are arrangements of elements, vehicles, and soldiers in relation to each other. Platoons use formations for control, flexibility, and security. Leaders choose formations based on METT-T. Platoon leaders are normally up front in formations during mounted movement, and team leaders are up front in formations during dismounted movement. This allows them to lead from the front and lead by example. All Bradley commanders (mounted) and soldiers (dismounted) in the formations must be able to see their leader. The speed of movement and distance between vehicles or soldiers in formations will vary according to the METT-T situation at the time. Each vehicle or person will be guarding and searching a different sector to provide all-round security while on the move. Platoons use column, line, echelon, and wedge formations for mounted movement. The dismounted platoon uses column and line formations.

a. **Mounted.** Column, line, echelon, and wedge formations, modified as necessary, determine the position of vehicles in relation to each other and the orientation of turrets in sectors of responsibility for scanning and fire. This allows the platoon to act appropriately in most situations and during most conditions. Action on enemy contact, as well as the requirement to change formations on the move, must be a matter of implementing one of a series of standard, thoroughly trained drills. Herringbone and coil are the security formations used when the vehicles are not moving.

(1) **Column.** The column formation is used for road marches, for movement during limited visibility, and when passing through defiles or other restrictive terrain. (Figure 2-20, page 2-58.) The column simplifies control, provides good security, and permits maximum firepower to the flanks.

(2) **Line.** The line formation is used when assaulting a weakly defended objective, crossing open areas, or in a support-by-fire position. (Figure-21, page 2-58.) This formation provides maximum fire to the front. The distance between elements depends on terrain.

(3) **Echelon.** The echelon formation permits excellent firepower to the front and to either the right or left flank. (Figure 2-22, page 2-59.) It is normally used when a platoon is to cover an exposed flank of a larger force.

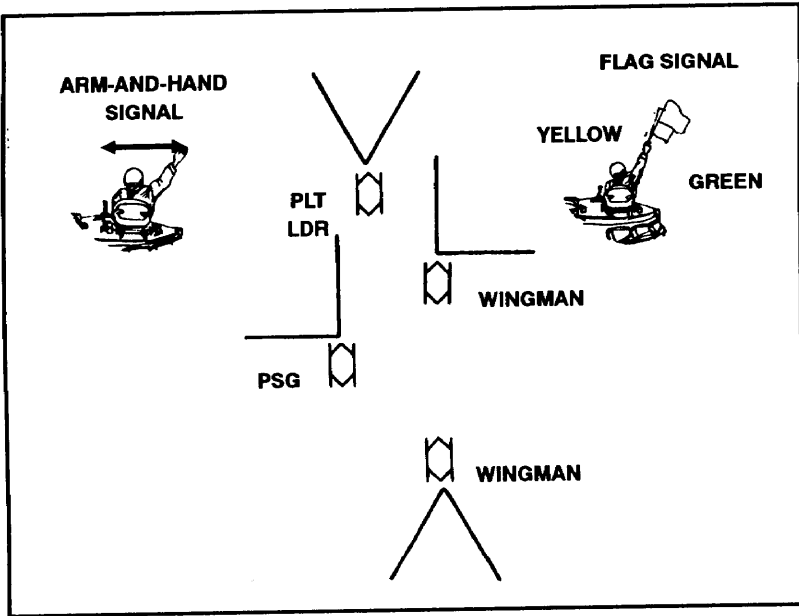

Figure 2-20. Column formation.

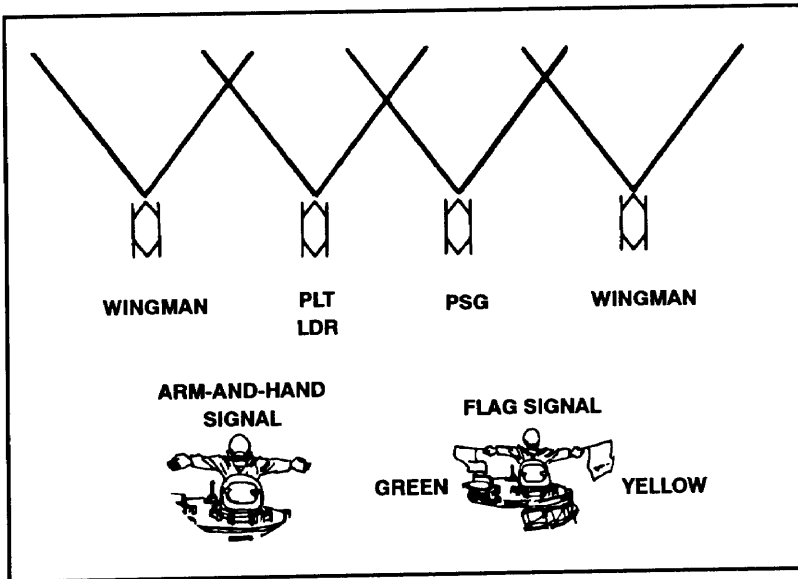

Figure 2-21. Line formation.

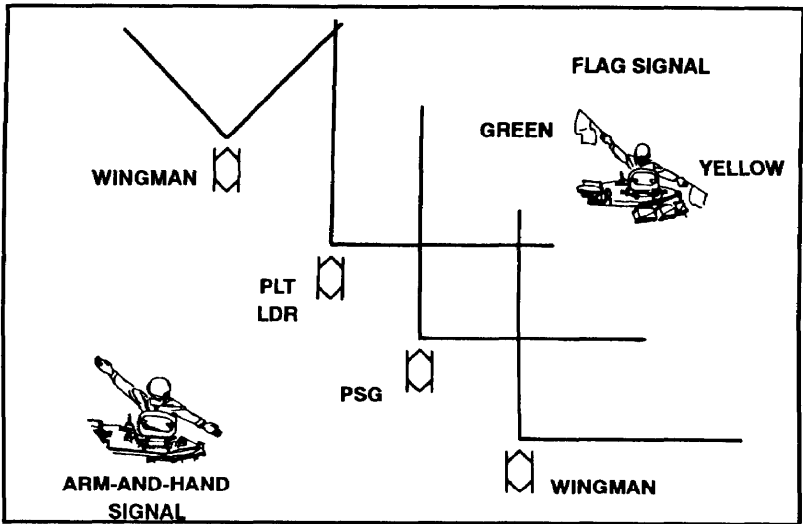

Figure 2-22. Echelon formation.

(4) *Wedge.* The wedge formation permits excellent firepower to the front and good fire to each flank. (Figure 2-23.) The wedge formation is often used when the enemy situation is vague.

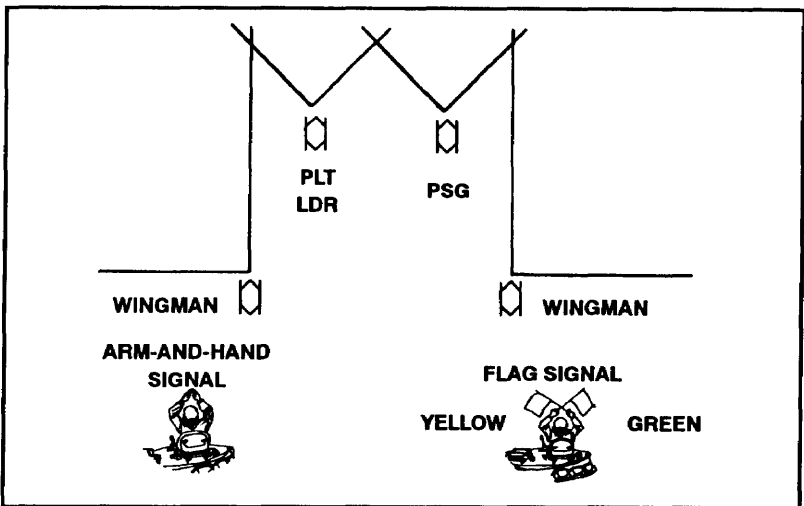

Figure 2-23. Wedge formation.

(5) **Herringbone.** The herringbone is used to disperse the platoon when traveling in column formation. (Figure 2-24.) It may be used during air attacks or when the platoon must stop during movement. It lets the platoon move to covered and concealed positions off a road or from an open area and establish air-round security without detailed instructions being issued. The vehicles are repositioned as necessary to take advantage of the best cover, concealment, and fields of fire. Fire team members dismount and establish security.

(6) **Coil.** The coil is used to provide all-round security and observation when the platoon is stationary. (Figure 2-25, page 2-61.)

It also is useful for tactical refueling, resupply, and issuing platoon orders. Security is posted to include airguards and dismounted fire teams. The vehicle turrets are manned.

b. **Dismounted.** Squads normally move mounted until the situation requires them to dismount. The squad moves alone or as part of the platoon's dismount element. The platoon's mounted element or other fire teams of the dismount element normally overwatch the movement of the dismounted squad. The dismount element uses a variety of formations.

(1) **Fire team formations.** Fire team formations describe the positioning of soldiers in relation to each other. Each formation has advantages and disadvantages. The leader must weigh these in light of his METT-T analysis. (Table 2-1, page 2-63.)

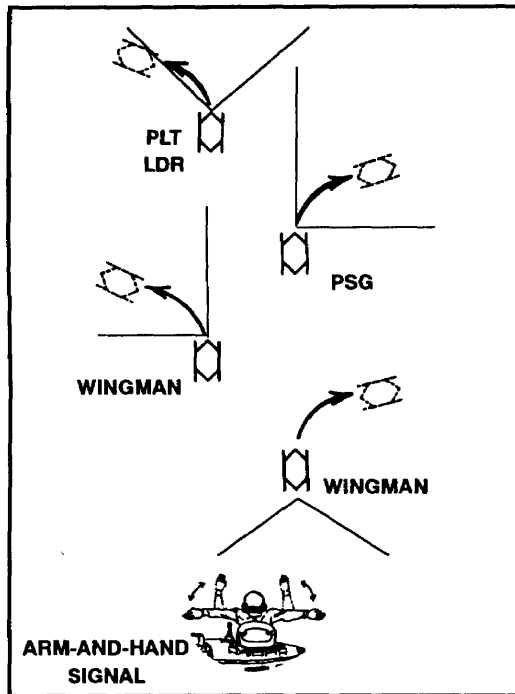

Figure 2-24. Herringbone formation.

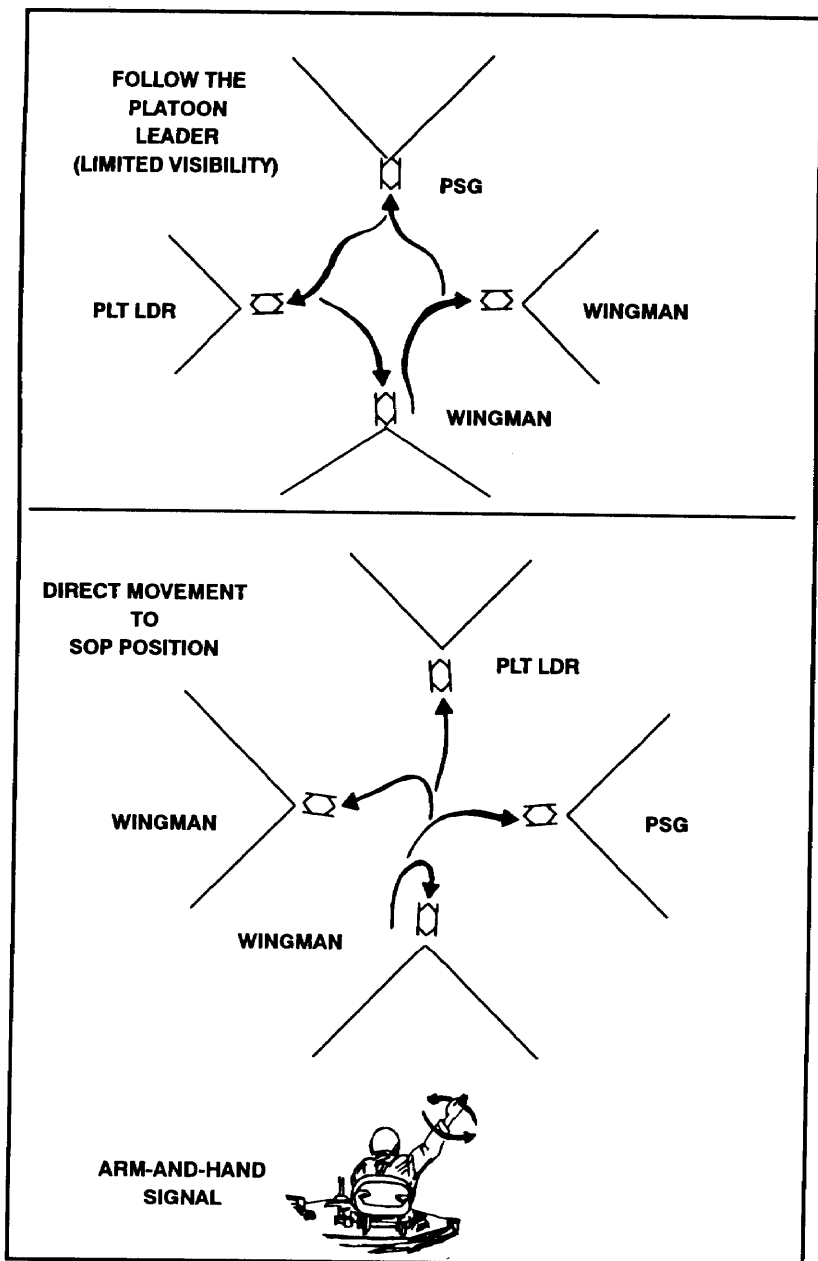

Figure 2-25. Coil formation.

(a) *Wedge*. The wedge is the basic formation for the fire team. The interval between soldiers in the wedge formation is normally 10 meters. The wedge expands and contracts depending on the terrain. When rough terrain, poor visibility, or other factors make control of the wedge difficult, fire teams modify the wedge. The normal interval is reduced so that all team members can still see their team leader and the team leaders can still see their squad leader. The sides of the wedge can contract to the point where the wedge resembles a single file. When moving in less rugged terrain, where control is easier, soldiers expand or resume their original positions. (Figure 2-26.)

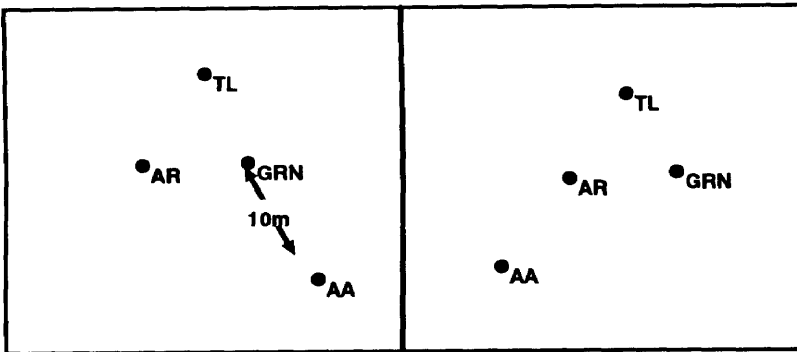

Figure 2-26. Fire team wedge.

(b) *File*. When the terrain precludes use of the wedge, fire teams use the file formation. (Figure 2-27.)

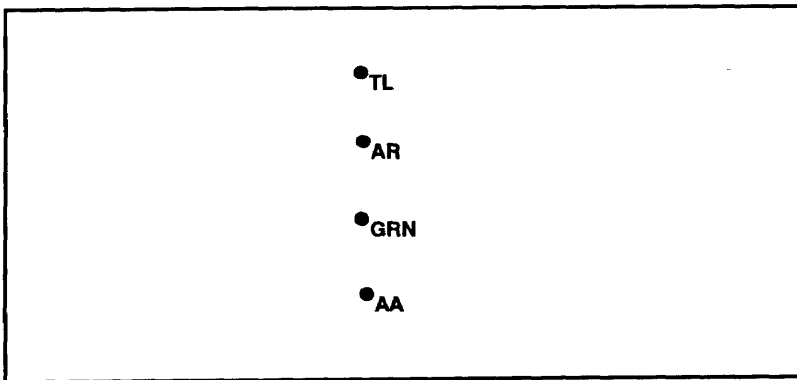

Figure 2-27. Fire team file.

MOVEMENT FORMATION	WHEN NORMALLY USED	CHARACTERISTICS			
		CONTROL	FLEXIBILITY	FIRE CAPABILITIES/ RESTRICTIONS	SECURITY
FIRE TEAM WEDGE	BASIC FIRE TEAM FORMATION.	EASY	GOOD	ALLOWS IMMEDIATE FIRES IN ALL DIRECTIONS.	ALL-ROUND
FIRE TEAM FILE	CLOSE TERRAIN DENSE VEGETATION, LIMITED VISIBILITY CONDITIONS.	EASIEST	LESS FLEXIBLE THAN THE WEDGE.	ALLOWS IMMEDIATE FIRES TO THE FLANKS. MASKS MOST FIRES TO THE REAR.	LEAST

Table 2-1. Comparison of fire team formations.

(2) Squad formations.

Squad formations describe the relationships between fire teams in the squad. They include the squad column, squad line, and squad file. A comparison of the formations is in Table 2-2, page 2-65.

(a) *Squad column.* The squad column is the squad's main formation. It provides good dispersion laterally and in depth without sacrificing control, and facilitates maneuver. The lead fire team is the base fire team. Squads can move in either a column wedge or a modified column wedge. (Figure 2-28.) Rough terrain, poor visibility, or other factors can require the squad to modify the wedge into a file for control purposes. As the terrain becomes less rugged and control becomes easier, the soldiers assume their original positions.

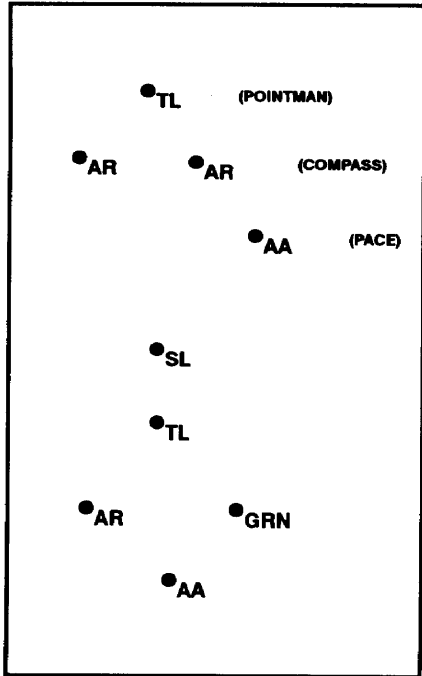

Figure 2-28. Squad column with fire teams in column.

(b) *Squad line.* The squad line provides maximum firepower to the front. (Figure 2-29, page 2-64.) When a squad is acting as the base squad, the fire team on the right is the base fire team.

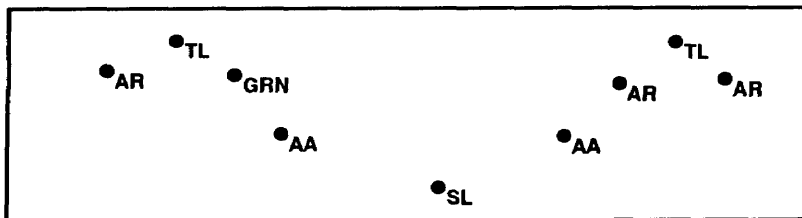

Figure 2-29. Squad line.

(c) *Squad file.* When not traveling in a column or line, squads travel in file. The squad file has the same characteristics as the fire team file. If the squad leader wishes to increase his control over the formation, exert greater morale presence by leading from the front, and be immediately available to make key decisions, he will move forward to the first or second position. Additional control over the rear of the formation can be provided by moving a team leader to the last position. (Figure 2-30.)

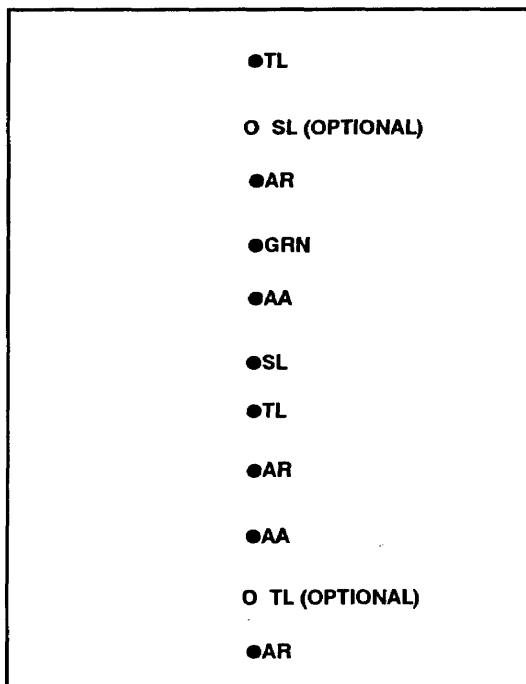

Figure 2-30. Squad file.

MOVEMENT FORMATION	WHEN NORMALLY USED	CHARACTERISTICS			
		CONTROL	FLEXIBILITY	FIRE CAPABILITIES/ RESTRICTIONS	SECURITY
SQUAD COLUMN	SQUAD PRIMARY FORMATION.	GOOD	FACILITATES MANEUVER, GOOD DISPERSION LATERALLY AND IN DEPTH.	ALLOWS LARGE VOLUME OF FIRE TO THE FLANKS— LIMITED VOLUME TO THE FRONT.	ALL-ROUND
SQUAD LINE	WHEN MAXIMUM FIRE POWER IS REQUIRED TO THE FRONT.	NOT AS GOOD AS SQUAD COLUMN.	LIMITED MANEUVER CAPABILITY (BOTH FIRE TEAMS COMMITTED).	ALLOWS MAXIMUM IMMEDIATE FIRE TO THE FRONT.	GOOD TO THE FRONT, LITTLE TO THE FLANKS AND REAR.
SQUAD FILE	CLOSE TERRAIN VEGETATION, LIMITED VISIBILITY CONDITIONS.	EASIEST	MOST DIFFICULT FORMATION FROM WHICH TO MANEUVER.	ALLOWS IMMEDIATE FIRE TO THE FLANKS. MASKS MOST FIRE TO THE FRONT AND REAR.	LEAST

Table 2-2. Comparison of squad formations.

(3) **Platoon formations.** The platoon uses the column or line formations. (Figures 2-31 and 2-32, page 2-66.)

(a) **Column.** The column is the platoon primary movement formation. It provides good dispersion both laterally and in depth, and simplifies control. This formation can deliver a limited volume of fire to the front and high volume to the flanks. The lead squad is the base squad.

(b) **Line.** It provides good lateral dispersion. In this formation, the platoon can deliver the greatest amount of fire to the front. The platoon leader designates the base squad. The transition from movement techniques to maneuver must be done quickly to attain the initiative.

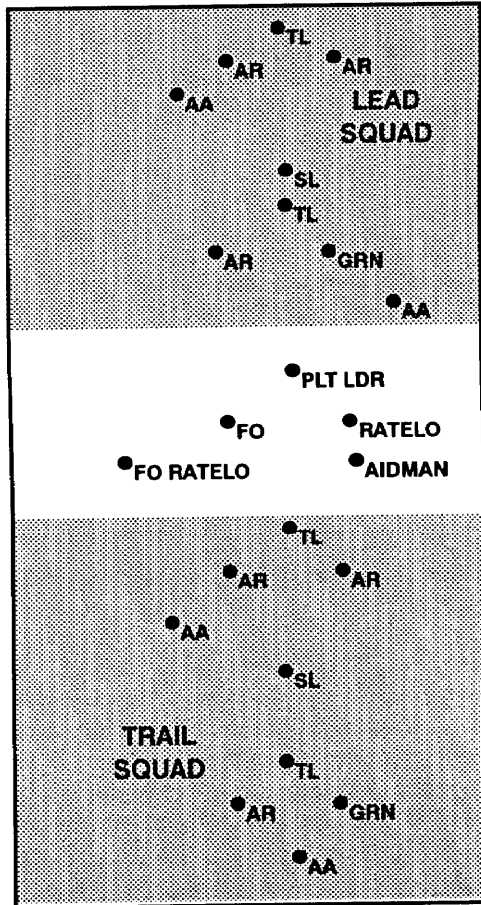

Figure 2-31. Platoon column.

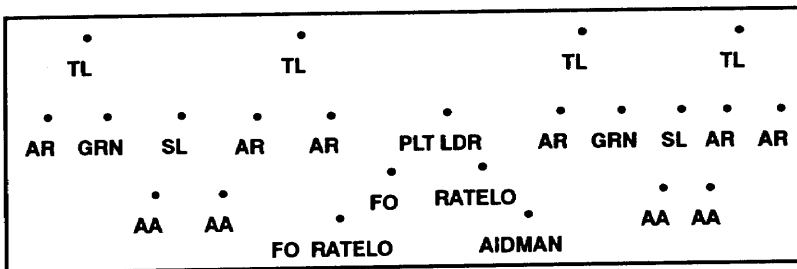

Figure 2-32. Platoon line.

2-9. MOVEMENT TECHNIQUES

A movement technique is the manner a platoon uses to traverse terrain. There are three movement techniques: traveling, traveling overwatch, and bounding overwatch. The selection of a movement technique is based on the likelihood of enemy contact and the need for speed. Factors to consider for each technique are control, dispersion, speed, and security (Table 2-3.) Movement techniques are not fixed formations. They refer to the distances between vehicles (mounted movement), soldiers, teams, and squads that vary based on mission, enemy, terrain, visibility, and any other factor that affects control.

MOVEMENT TECHNIQUES	WHEN NORMALLY USED	CHARACTERISTICS			
		CONTROL	DISPERSION	SPEED	SECURITY
TRAVELING	CONTACT NOT LIKELY	MORE	LESS	FASTEST	LEAST
TRAVELING OVERWATCH	CONTACT POSSIBLE	LESS	MORE	SLOWER	MORE
BOUNDING OVERWATCH	CONTACT EXPECTED	MOST	MOST	SLOWEST	MOST

Table 2-3. Movement techniques and characteristics.

a. Mounted.

(1) **Traveling.** Traveling is used when contact with the enemy is not likely and speed is needed (Figure 2-33, page 2-68.)

(2) **Traveling overwatch.** Traveling overwatch is used when contact is possible. A platoon in traveling overwatch may move in a column, wedge, or echelon formation with turrets oriented into assigned sectors of responsibility. (Figure 2-34, page 2-68.) (As noted earlier, the platoon should move mounted in sections—one under the platoon leader's control, the other controlled by the platoon sergeant.)

(3) **Bounding overwatch.** Bounding overwatch is used when contact is expected. Platoons execute bounding overwatch in alternate or successive bounds. (Figure 2-35, page 2-69.) Platoons use alternate bounds when speed is important and when terrain is open. They use successive bounds to move deliberately or when terrain is restrictive.

(a) When the platoon uses mounted bounding overwatch, one or two vehicles bound while the others overwatch from a stationary position. (Figure 2-36, page 2-69.) When the new position is reached, the bounding fire teams dismount for local security. If the new position is relatively open, the bounding section may not need dismounted personnel to secure the position. As soon as the position is secured, the bounding section covers the rest of the platoon as they move forward. The process is repeated for subsequent moves.

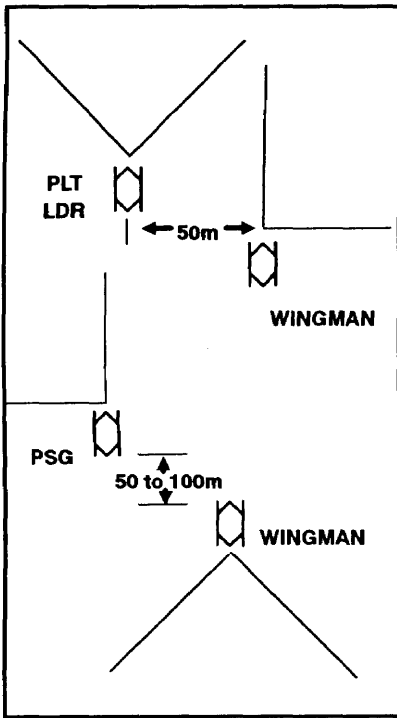

Figure 2-33. Traveling, platoon mounted.

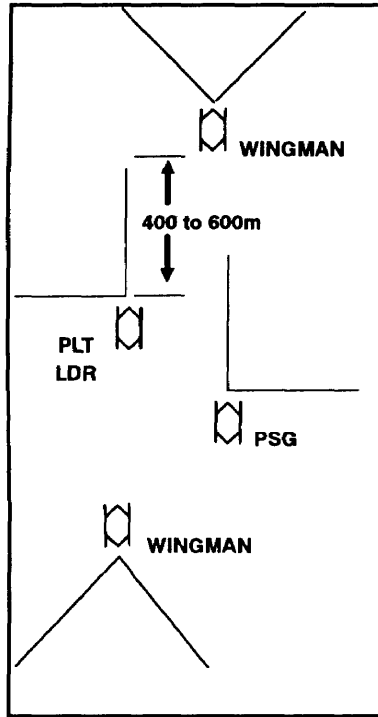

Figure 2-34. Traveling overwatch.

(b) The vehicles in the overwatch should follow the platoon or company SOP for weapons-ready posture. For example, all BFVs might have their TOW launchers erected and self-tested with one of the BFVs designated to fire, and another ready to fire its 25-mm gun or 7.62-mm coaxial machine gun. Each gunner should be prepared for immediate engagement in accordance with the platoon leader's fire control and distribution plan. Designated gunners should have their thermal sights on. Those BFVs chosen to have the 25-mm gun ready should select the proper ammunition and rate of fire, and turn the range index knob to the estimated range of the most likely target. Those BFVs selected to have the 7.62-mm coaxial machine gun ready also turn their range control knob to the range of the most likely target. This arrangement ensures that the overwatch force can provide immediate and accurate fire support with the proper weapon and ammunition. This can be adjusted to fit the enemy situation, terrain, and availability of ammunition and missiles.

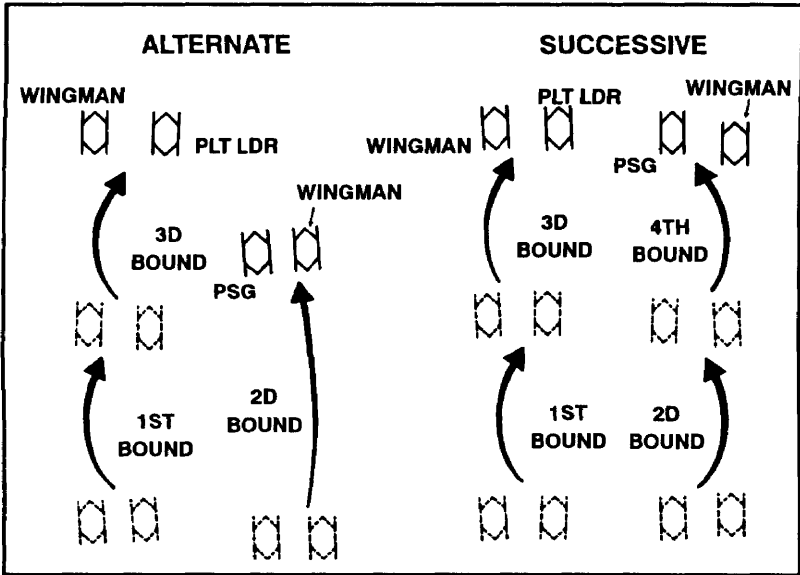

Figure 2-35. Methods of bounding overwatch.

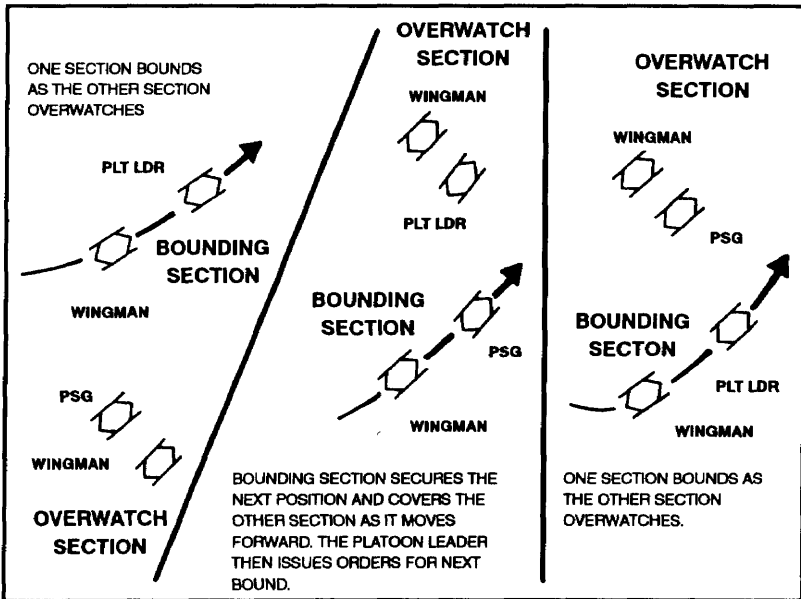

Figure 2-36. Bounding overwatch.

b. **Dismounted.** The platoon normally remains mounted until forced to dismount. When it dismounts, it uses the following techniques.

(1) **Traveling.** This technique is not used often when contact is not likely, because the platoon normally remains mounted. (Figure 2-37.) Sometimes the platoon has missions that require the dismount element to operate independent of the BFVs. The traveling technique is normal for trailing platoon dismounted elements in a company dismounted formation. The element's formation is adjusted to fit the situation.

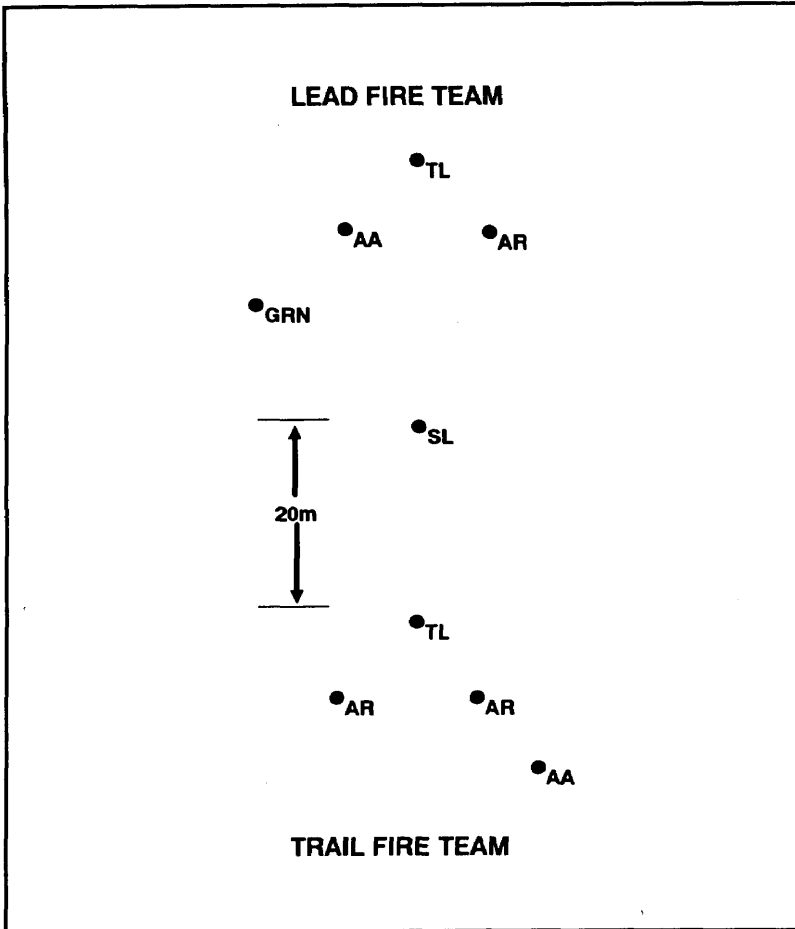

Figure 2-37. Traveling, squads dismounted.

(2) **Traveling overwatch.** The dismount element normally uses a column or wedge formation. The lead team tries to move at least 50 meters, but preferably 100 meters or more, in front of the rest of the element. The BFVs may be even farther to the rear or to a flank. (Figure 2-38.)

(3) **Bounding overwatch.** When contact is expected and the terrain does not permit mounted movement or when the dismount element is separated from the vehicles, the platoon (-) bounds with the dismount element deployed. (Figure 2-39, page 2-72.)

(4) **Movement during limited visibility conditions.** At night or when visibility is poor, a platoon must be able to function the same as during day. It must be able to control, navigate, maintain security, and move at night or during limited visibility.

(a) **Control.** When visibility is poor, the following methods aid in control:

- The platoon uses vehicle night vision devices when mounted and selected personnel use night vision devices when dismounted.
- Leaders move closer to the front.
- The platoon reduces speed.
- The platoon uses small strips of luminous tape or chemical light on the rear of vehicles or helmets to ensure the vehicle or soldier behind them can maintain visual contact.
- Leaders reduce the interval between vehicles, soldiers, and squads to make sure they can see each other.
- During dismounted movement, leaders conduct headcounts at regular intervals and after each halt to ensure personnel accountability.

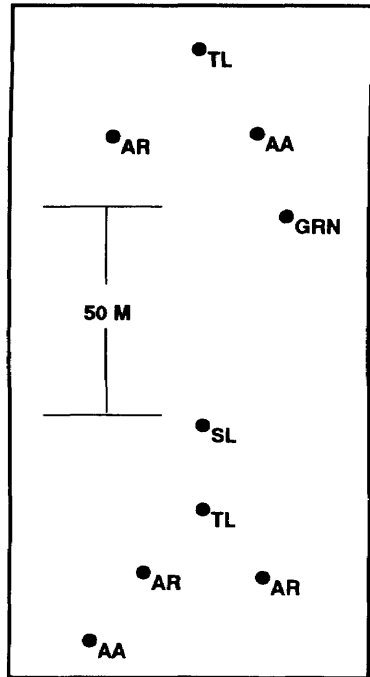

Figure 2-38. Traveling overwatch, squads dismounted.

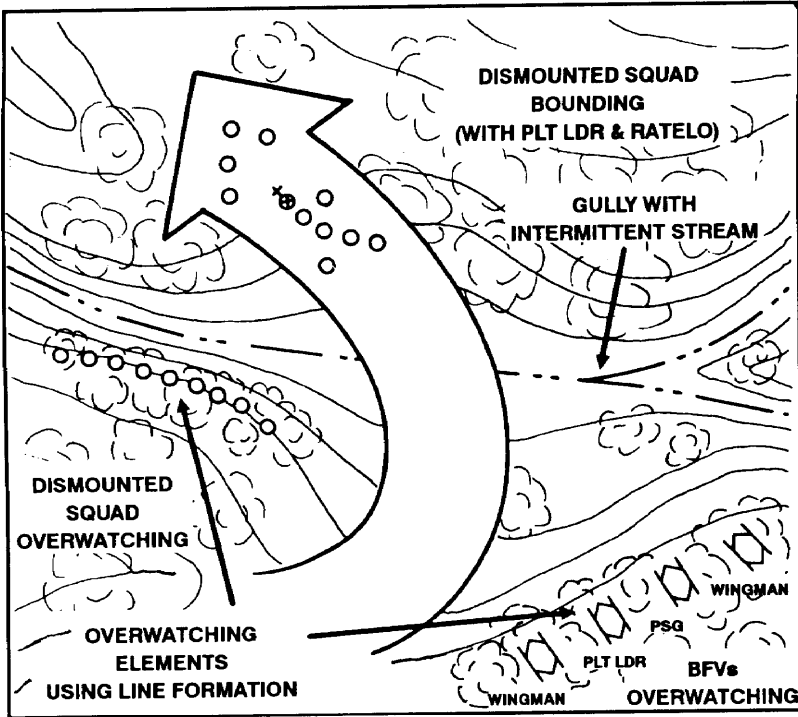

Figure 2-39. Bounding overwatch, squads dismounted.

(b) *Navigation.* To assist in navigation during limited visibility, leaders use—

- Terrain association (general direction of travel coupled with recognition of prominent map and ground features).
- Dead reckoning (compass direction and specific distances or legs). At the end of each leg, leaders should verify their location.
- Resection.
- Movement routes that parallel identifiable terrain features.
- Guides to marked routes.
- GSRs to vector platoons to the proper location.
- Position-location devices.
- Thermal sights.

(c) **Security.** For stealth and security in night moves, squads and platoons—

- Use radio-listening silence.
- Use terrain to avoid detection by enemy surveillance or night vision devices.
- Make frequent listening halts during dismounted movement.
- Mask the sounds of movement with artillery fires.

c. **Individual Movement Techniques.** Individual movement techniques include the high and low crawl and short rushes (three to five seconds) from one covered position to another. (See FM 21-75.)

d. **Other Movement Situations.** The platoon can use other formations for movement.

(1) **Movement with armored vehicles.** For a detailed discussion of BFV and tank operations, see Section IX.

(2) **Movement by water.** Platoons avoid crossing water obstacles when possible. Leaders should identify weak or nonswimmers when crossing water in BFV and pair them with a good swimmer in their crew/squad.

2-10. ACTIONS AT DANGER AREAS

The infantry platoon normally moves mounted to take full advantage of the firepower, speed, and protection of the BFV. When moving through forested areas, towns, or where there is a possibility of an ambush, the platoon leads with the dismounted infantry to protect against enemy short-range ATGM. Defiles, bends in roads, or river crossing sites are likely enemy locations.

a. Rifle squads or engineers when available are deployed to breach obstacles, to find a route around impassable terrain, and to provide security. Because the BFV is vulnerable to short-range ATGM, suspected vehicle ambush areas must be rested with caution. If available, fire from tank main guns can be used to force through hastily constructed obstacles, after the obstacle area has been secured by infantry. This technique keeps the momentum up and does not require that the force wait for engineers to be brought forward.

b. One of the major tasks of the lead element is protection of the company or company team from surprise attack. The lead platoon must clear each possible ambush site unless instructed otherwise.

c. When a danger area is encountered that makes an enemy ambush possible, the company team commander makes the determination as to how much risk he will take. If speed is critical, he may choose to take a greater risk and not dismount, or he may choose to stay mounted but move

forward only a small element. If he has reason to believe that an ambush is likely, then he will probably dismount the infantry. He may also "reconnoiter by fire into the likely enemy position.

DANGER

THE BFV SHOULD NEVER FIRE ARMOR-PIERCING AMMUNITION WHILE DISMOUNTED FRIENDLY SOLDIERS ARE WITHIN A GUN ARC OF 10 DEGREES AND WITHIN 400 METERS, UNLESS OVERHEAD COVER IS AVAILABLE FOR DISMOUNTED SOLDIERS. IF ROUNDS ARE FIRED OVER THE DISMOUNTED ELEMENT, DISMOUNTED SOLDIERS COULD BE KILLED OR INJURED BY THE DISCARDING SABOT OR PLASTIC THAT FALL OFF ROUNDS FIRED FROM THE BFVs OR TANKS. (TANK SAFETY ARC IS 70 DEGREES AT 1,000 METERS.)

d. In each situation where dismounted infantry lead BFVs and tanks, the company team commander decides whether tanks or BFVs move directly behind the dismount element. Tanks are normally preferred, because their large main guns and machine guns can deliver immediate, devastating fire, and they have much better armor protection than the BFVs. Regardless of whether tanks or BFVs are the overwatch force, they must be ready, once contact is made, to suppress enemy weapons that endanger the dismounted infantry.

e. A defile is a narrow passage that constricts the movement of soldiers. It is an ideal ambush site. If a defile is encountered that forces the company team to move in single vehicle file for a significant distance, the commander might choose to lead with dismount infantry. (Figure 2-40.) Common defiles for mechanized platoons are roads or trails across streams or through swamps and heavy forests. When clearing a defile, the dismount element clears each side far enough from the choke point to make sure that there are no ambushes. It also checks the surface for evidence of mines. Because contact should be expected at defiles, the leading squad should use bounding overwatch.

f. If a platoon is given the task of clearing a road as part of a movement to contact, it must use caution. The enemy often employs antiarmor weapons on a bend in the road so that he can ambush lead vehicles without trailing vehicles overmatching. A bend in the road

and its shoulder may also be mined; therefore, squads must carefully check bends in roads.

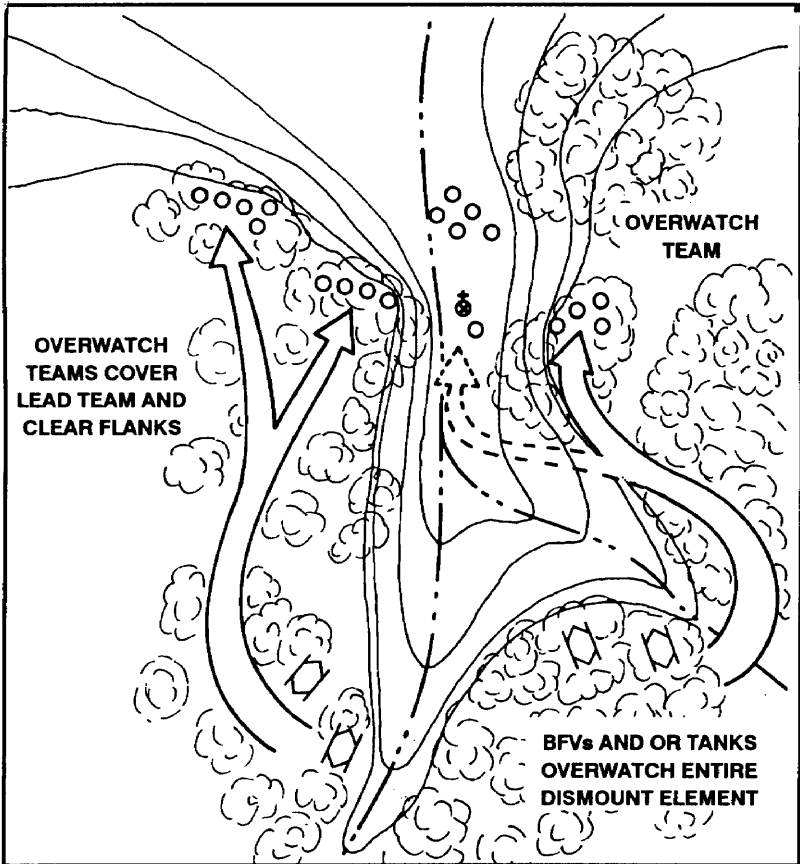

Figure 2-40. Clearing a defile.

g. A bridge must be considered an obstacle or possible ambush site and approached as such. It must be cleared before it is crossed.

h. Infantrymen normally dismount to lead through urban areas. (Figure 2-41, page 2-76.) Vehicle movement through a village or town is generally limited to streets and infantrymen must clear buildings along the way. The infantrymen move down a street with squads staggered along the street sides. The infantrymen move alongside the buildings, clearing each building as they advance. As it moves,

each platoon makes sure there are no enemy positions left in the buildings on its side of the street. Each team looks for enemy in the upper floors of the buildings on the other side of the street. Tanks or BFVs provide overwatch. A single platoon should be responsible for clearing a single street to enhance command and control.

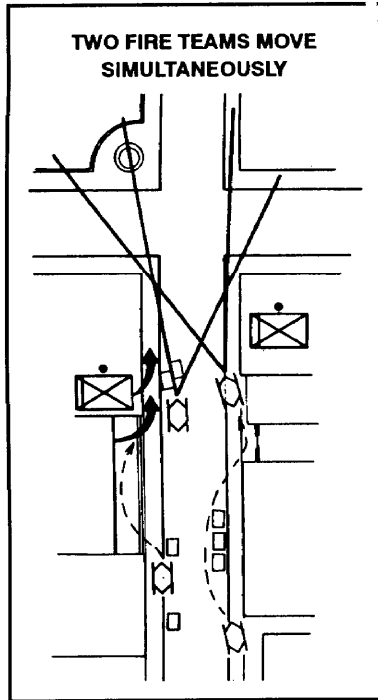

Figure 2-41. Dismount element leading.

Section IV OFFENSE

This section provides techniques and procedures for offensive missions. It includes movement to contact, deliberate attack, and consolidation and reorganization on the objective.

2-11. MOVEMENT TO CONTACT

Unless the platoon is in direct contact with the enemy, most offensive operations begin with a movement to contact. Its purpose is to gain or maintain contact with the enemy and to develop the situation to conduct either a hasty or deliberate attack. Movement to contact is usually characterized by a lack of detailed information about the enemy. Once contact is made, the leader determines the enemy strength; the location of flanks, gaps, weaknesses; and possible enemy intentions.

a. **Conduct a Movement to Contact.** Platoons and squads participate in a movement to contact as part of a company/team using movement formations and techniques explained in Chapter 3.

(1) Because the enemy situation is vague, the platoon must be prepared to act in any situation. This is accomplished by proper planning, war-gaming, using appropriate movement formations and techniques, using fire control measures, using platoon SOPs, using engagement criteria, and studying the terrain before and during movement to anticipate likely enemy locations. While moving, all leaders study the terrain and anticipate enemy contact and what actions to take. (Figure 2-42, page 2-78.)

(2) Because the platoon leader does not know when or where he will make contact with the enemy, he should avoid mounted movement on terrain that restricts maneuver such as draws, ravines, narrow trails, or steep slopes. The platoon leader must also consider the speed at which the commander expects him to move when selecting his route. If restrictive terrain is unavoidable, the platoon leader will consider alternative techniques to enhance security, for example, dismount a squad or fire team to conduct a movement through the restrictive area in advance of the vehicles.

(3) A line of departure, phase lines, and checkpoints are normally assigned to control the forward movement of the company or company team. The platoon leader may be required to report these graphic control measures to the commander. The platoon does not stop at a phase line unless told to do so. If necessary, the platoon leader may designate additional phase lines or checkpoints for internal platoon use to reduce the number and length of radio transmissions used to control movement.

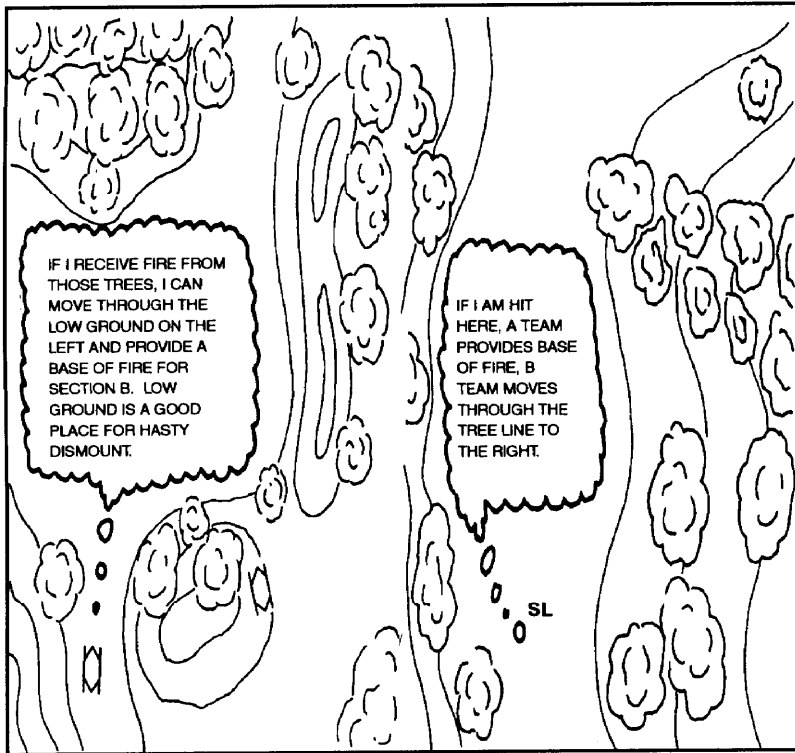

Figure 2-42. Anticipate enemy contact.

(4) Fire control and distribution are accomplished through the use of boundaries, fire plans, pyrotechnics, and weapons-ready posture. It takes on added importance in the movement to contact because of the scarcity of information about the enemy. The weapons-ready posture must be flexible enough to respond to an unclear enemy situation, and it will vary between the bounding and overmatching elements. It is critical in BFV-equipped platoons because of the variety of weapons that can be controlled from the turret and the dangers of expending all of the on-board ammunition of a weapon within the platoon.

(a) The overwatching element should erect their TOWs and perform the self-test, and the designated vehicles prepare 25-mm HEI-T, APDS-T, and 7.62-mm coax.

(b) When restrictive terrain dominates the route, the bounding element may not have the same fields of fire as the overmatching element

and may be less capable of employing TOWs. Once again, the leader designates which vehicles will prepare to fire the various weapons and types of ammunition. A mounted overmatching element is not the only technique in restrictive or slow-go terrain. The platoon leader may also decide to use a combination of a long-range overwatch (BFVs) and a dismounted squad or fire team as a short-range overwatch. In this case, soldier and vehicle locations, limits of fire, and signal control measures are all important to minimize the chances of fratricide.

(5) Without instructions the forward observer must, based on spot reports or observation, inform the platoon leader that he is ready to adjust indirect fires. This must be an automatic response. The mounted (during mounted movement, the platoon leader adjusts indirect fires) and dismounted elements must both have this capability.

(6) If there is no platoon FO, the platoon leader must still have a good indirect fire plan for his route to cover anticipated places of contact. These targets are reasoned from the platoon leader's wargaming process and incorporated into the company plan. With no FO, the platoon leader should initiate the call for fires on the command net, with the FIST leader eavesdropping. The FIST leader generates the immediate or preplanned mission. The adjustment process can be done via alternate methods.

(7) Air guards are critical in a movement to contact. If the cargo hatch is open, an air-guard can be designated to watch the sides and rear; the front view is blocked by the turret. The Bradley commander in one or more of the BFVs must act as an air guard oriented to the front.

(8) Once the platoon makes contact with the enemy, it is maintained until the commander orders otherwise. The platoon leader develops the situation based on effectiveness of enemy fire, friendly casualties, size of enemy force, and freedom to maneuver. He gathers and reports critical information about the enemy and recommends a course of action. There are several options the commander and the platoon leader can execute once contact is made. The platoon could bypass the enemy with permission from the commander, conduct a hasty attack, fix the enemy so another platoon can conduct the assault, or conduct a hasty defense or establish a hasty ambush. (Figure 2-43, page 2-80.) The following are guidelines which can be used for planning and when contact is made to develop the situation.

(a) Light resistance is resistance from an enemy squad-sized element or smaller that is not causing friendly casualties, and the enemy force is equipped with or without an armored vehicle, in hasty fighting position with no obstacles, and primarily hand-held antiarmor weapons.

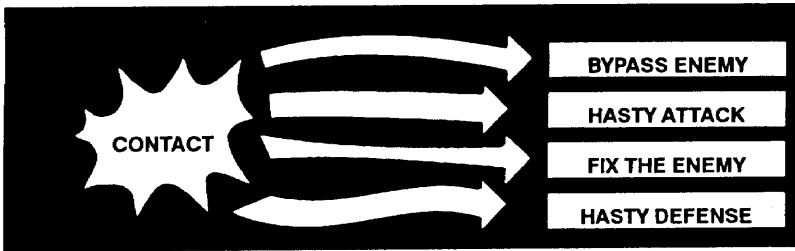

Figure 2-43. Movement to contact options.

(b) Medium resistance is resistance from an enemy squad- to platoon-sized element that is causing light friendly casualties. The enemy defense is organized around the best defensible terrain with combined arms assets integrated.

(c) Heavy resistance is resistance from an enemy platoon-sized element or larger that is causing heavy friendly casualties. The enemy is defending a strongpoint with combined arms assets.

(9) Light resistance may be bypassed IAW the OPORD or when directed by the commander. Once the platoon reacts to contact and the decision has been made to bypass, the following actions occur. (Figure 2-44.)

- BFVs suppress on the move.
- Infantry remains mounted.
- Platoon leader calls for and adjusts indirect fire and smoke to screen his movement past the enemy position.
- Platoon leader reports the size and the location of the enemy to the company/team commander, and the platoon continues the mission.

(10) Once the platoon reacts to contact and the decision is made to conduct a hasty attack, the actions of the platoon areas follows:

(a) Light resistance (Figure 2-45)–

- One section of BFVs provides long-range overwatch from a covered position or supporting fires on the move, especially against enemy ATGM.
- The other section maneuvers to conduct the assault.
- The platoon leader calls for and adjusts indirect fire to suppress the enemy.

- Infantry remains mounted unless the enemy must be cleared from restrictive terrain, or unless forced to dismount by enemy resistance.
- The platoon conducts consolidation and reorganization.
- The platoon leader reports the status, and the platoon continues the mission.

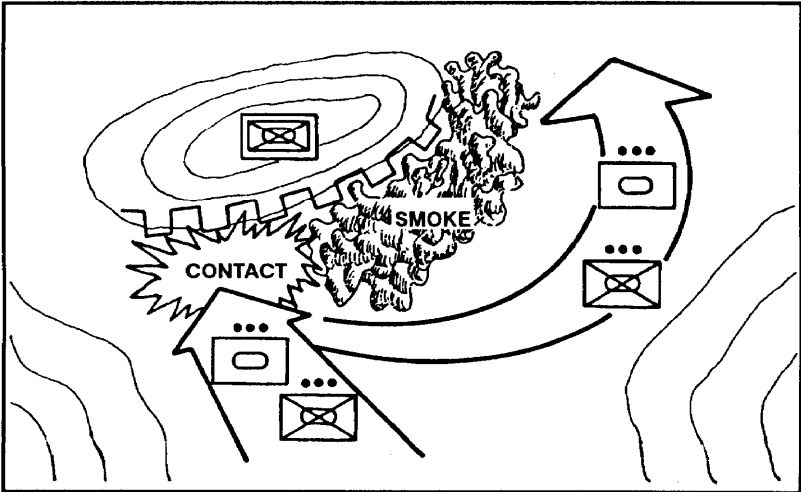

Figure 2-44. Bypass the enemy.

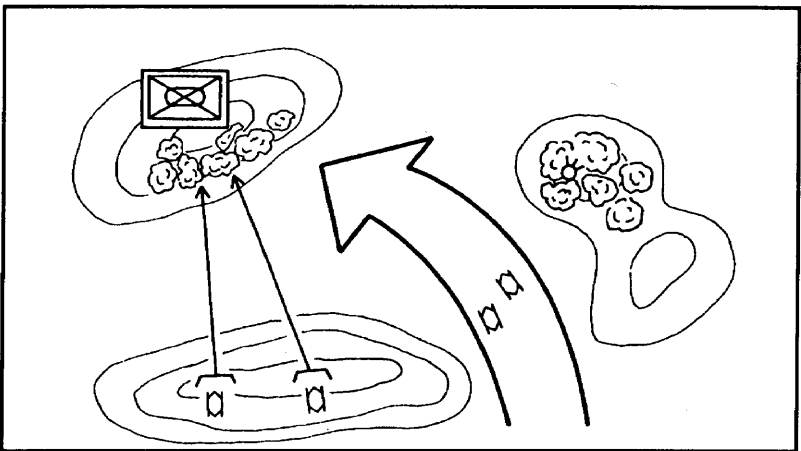

Figure 2-45. Hasty attack—light resistance.

(b) Medium resistance (Figure 2-46)–

- BFVs suppress the enemy from support-by-fire positions and maneuver against the enemy if a trafficable, covered and concealed approach is available.
- The platoon leader calls for and adjusts indirect fires to suppress the enemy and smoke to screen the movement.

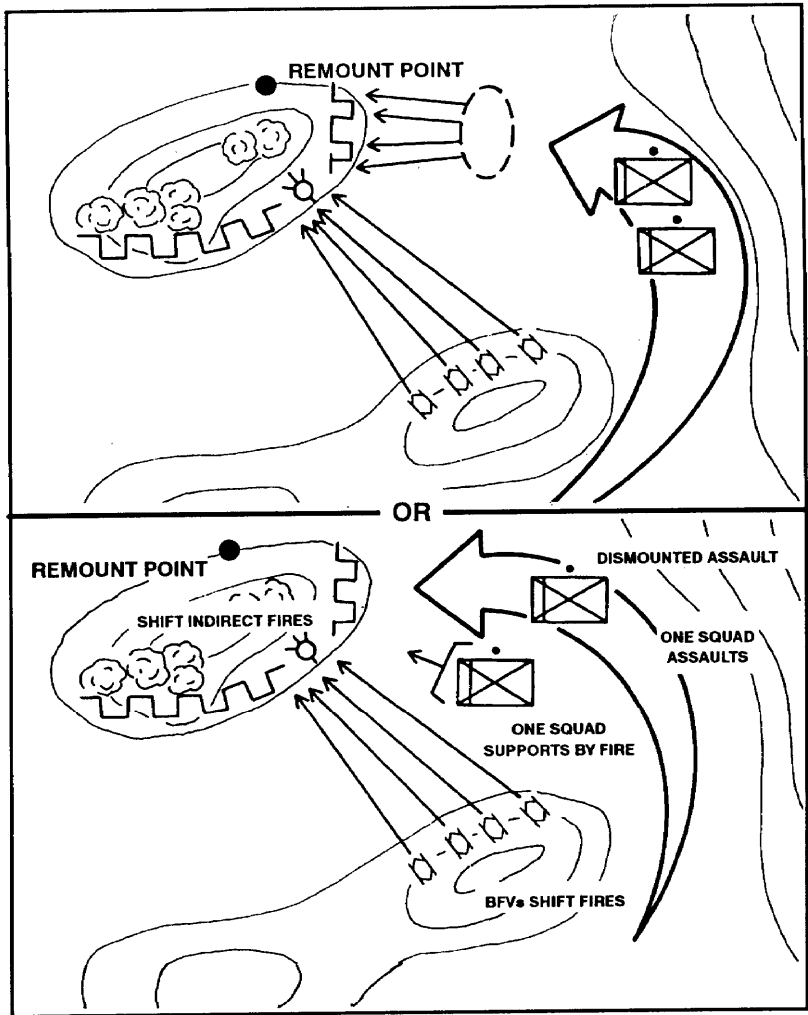

Figure 2-46. Hasty attack—medium resistance.

- BFVs immediately suppress the enemy from a hull-down position, while the infantry dismounts. EFVs continue to suppress while the infantry moves to the objective. The BFVs keep fires in front of the infantry as they conduct the assault.
- If the BFVs can maneuver closer to the objective, the BCs search for hull-down positions to serve as dismount points and support-by-fire positions. The BFVs then continue to suppress the enemy, while the infantry moves to the objective. Supporting fires are kept in front of the infantry as they conduct the assault.
- The infantry conducts the assault using fire and movement. One squad supports by fire while one squad moves. The platoon leader and FO moves with the squad conducting the assault to control the movement and adjust or control all supporting fires.
- Once the dismount element assaults across the objective, the platoon leader calls the BFV forward to assist in securing the objective.
- The platoon conducts consolidation and reorganization.
- The leader reports to higher headquarters.
- The dismount element remounts the BFVs, and the platoon continues the mission.

(11) If a bypass or hasty attack is not possible, the platoon may be instructed to fix the enemy. Fixing the enemy involves establishing a base of fire to suppress the enemy and keep him from repositioning any part of his force for use elsewhere. (Figure 2-47, page 2-84.) When enemy resistance is too heavy for the platoon to assault, or a hasty attack has failed, the actions of the platoon areas follows.

- (a) BFVs suppress from long-range support-by-fire positions.
- (b) Infantry dismounts to protect BFVs from ground attack or to secure a dismounted avenue of approach.
- (c) The platoon leader calls for and adjusts indirect fires to suppress the enemy.
- (d) The platoon prepares to lift or shift fires as other platoons conduct the assault.
- (e) Depending on the company formation and order of movement, platoons must be prepared to support by fire for another platoon while it conducts the assault or conducts the assault while other platoons support by fire.
- (f) If more than one platoon is involved, the commander issues instructions for fire control and distribution to the platoon leader. The platoon leader will then control the platoon fires as discussed earlier.

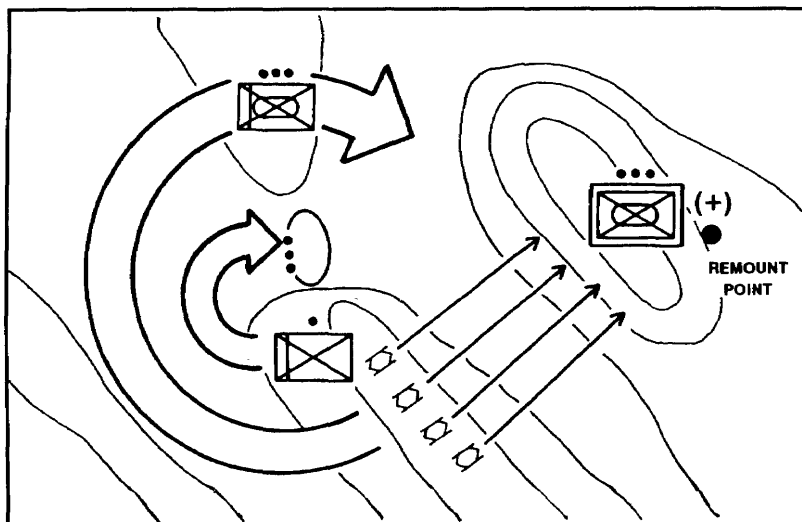

Figure 2-47. Fix the enemy.

b. **Conduct a Hasty Ambush.** Ambush is effective against a moving force that is not aware of the presence of the platoon. Instead of immediately opening fire, the platoon moves into hasty firing positions oriented on an engagement area. When most of the enemy formation is in the engagement area, the enemy is attacked by massed fires.

c. **Conduct a Hasty Defense.** (Figure 2-48.) In some situations, a platoon conducting a movement to contact will make contact with an enemy force much larger and more powerful. If the platoon encounters a larger enemy force where the terrain gives the platoon an advantage, it should attempt to fix the enemy force. This will allow the rest of the company team to maneuver against the force. If the platoon cannot fix the enemy, the platoon may be forced to assume a hasty defense. The hasty defense option should be used only if the platoon is in danger of being overwhelmed, because the hasty defense may surrender the initiative to the enemy and means that he has fixed the platoon. Exposed infantry is vulnerable to enemy indirect fires. If the platoon receives indirect fire, it should use the protection of the BFVs but observe and fight from the BFVs. BFVs use covered and concealed positions for protection from long-range ATGM. Once the indirect fires lift, the infantry immediately dismounts, and the platoon prepares for an enemy assault. In the hasty defense, the platoon leader does the following:

- Keeps the commander informed and continues to report on the enemy strength, dispositions, and actions.
- Dismounts infantry to secure BFVs or cover dismounted avenues of approach in preparation for the enemy's attack.
- Places BFVs in hull-down positions.
- Establishes fire control and distribution measures initially using fire patterns and engagement priorities.
- Calls for and adjusts indirect fires.
- Reports immediately to the company/team commander.

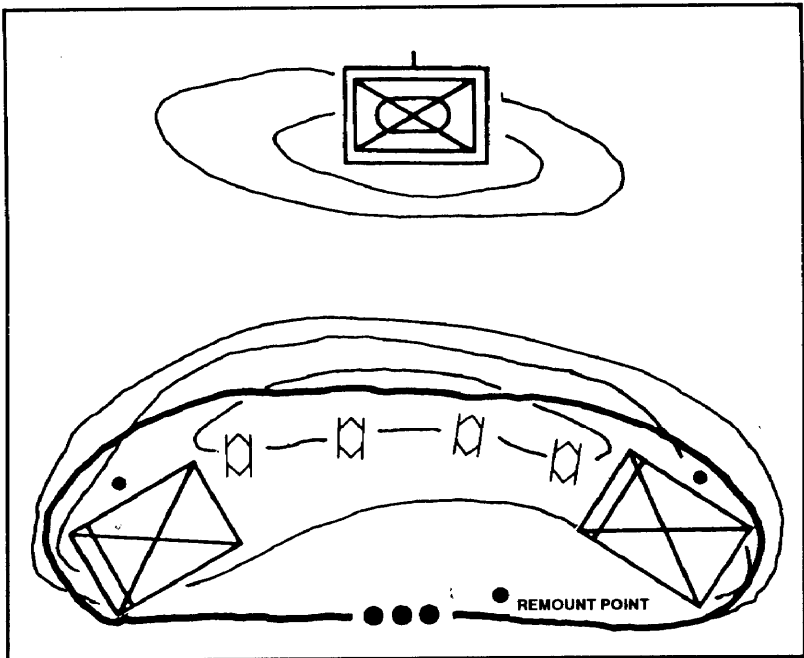

Figure 2-48. Hasty defense.

2-12. ATTACKS

Planning considerations for a deliberate and a hasty attack are the same. However, deliberate attack planning is characterized by more detailed information on the terrain and enemy. Also there is more time to coordinate organic and supporting assets, and to conduct reconnaissance. Because of the amount of time and information available for planning,

a deliberate attack is normally executed at a rapid pace; whereas, in a hasty attack, information must be acted on as it is received and the attack is conducted at a more controlled pace.

a. **Deliberate Attack.** A deliberate attack is an attack planned and carefully coordinated using all available assets and information. Mission and course of action analysis are conducted thoroughly. The principle is to mass the greatest possible combat power against the enemy's most vulnerable point while using combat multipliers and deception. BFV platoons conduct deliberate attacks as part of a larger force.

b. **Hasty Attack.** A hasty attack is an offensive operation for which a platoon has not made extensive preparations. It is conducted with the resources immediately available to maintain momentum or to take advantage of the enemy situation. The attack drill is used during the hasty attack.

c. **Planning Considerations.** On receipt of a company attack order, the platoon leader starts the troop-leading procedure and begins an estimate of the situation. When he has completed his mission analysis, the platoon leader develops his plan (scheme of maneuver and fire support plan).

(1) **Scheme of maneuver** Depending on the situation and the support provided by the rest of the company, the platoon leader decides the required elements (assault, support, breach, security, reserve) and the organization of each.

(a) **Formation.** The platoon moves as part of the company formation. The company commander directs not only the platoon's formation but may also direct the movement technique. The formation assists in the command and control and ensures swift, committed movement to the objective.

(b) **Command and control.** Based on the scheme of maneuver, the platoon leader selects a position within the platoon formation from which he can control the entire platoon. He selects the control measures needed for the operation and the best means to communicate with the squad and section leaders (voice commands, arm-and-hand signals, flags, whistles, radios, flares, and smoke). The platoon leader's responsibility is to control his platoon so that all available combat power is focused on the enemy and there are no errant fires that create fratricide incidents.

(2) **Fire support plan.** This plan is developed along with the scheme of maneuver, which it supports and complements. It discusses the use of all available direct and indirect fire. The goal is to kill as many enemy as possible and to suppress the rest to keep them from firing on the assaulting force. The company commander and FSO plan the indirect fires. However, the platoon leader and his FO can plan and request more targets if needed. The platoon leader plans the direct fires of his platoon.

(a) *BFVs*. The platoon leader can employ the BFVs to provide supporting fires for the dismounted element as they assault the objective.

(b) *Rifle squads*. The platoon leader has several options as to how to employ the rifle squads. He can use both squads to assault the objective while the BFVs provide supporting fires. He can also use one squad as part of the support element to provide close support while the other squad assaults the objective. Another option is to use the squads to fire the firing port weapons and clear or secure the objective during a mounted assault (resistance is unexpectedly light).

(c) *Indirect fire*. After receiving the company fire plan, the platoon leader checks it to ensure that targets are planned on all known or suspected enemy positions in front of, on, behind, and to the flanks of the objective. If more targets are required, the FO coordinates them with the FSO.

(d) *Other fire support*. Other fire support can come from Army and Air Force aircraft and air defense weapons. The company or battalion commander plans and controls this support. A platoon leader can request the support if he needs it.

2-13. CONDUCT OF A DELIBERATE ATTACK

The primary concern for infantry leaders in every attack is to accomplish the mission and reduce the time that their soldiers are exposed to the effects of enemy fire. They also seek to reduce the effectiveness of any fires they are exposed to. Success will be determined by how well this is accomplished in support of a plan that properly identifies the enemy weakness and concentrates combat power against it. The attack can be considered in phases—the assembly area to the LD, the LD to the assault position, the assault position to the objective, the actions on the objective, and finally the consolidation plan.

a. **Movement to the Objective Area.** The platoon moves toward the objective using the formations and techniques and employing the fundamentals discussed in Section III. Platoons must avoid detection during this phase of the attack. If detected at this range, the enemy has the time and the room to employ his most lethal weapons and munitions: mortars, field artillery, CAS, and possibly chemical weapons. Once detected by the enemy, the platoon must have sufficient suppressive fires and smoke to allow it to maneuver. If detected early, the platoon may require large amounts of sustained direct and indirect fires to support its maneuver.

b. **Assembly Area to the Line of Departure.** When the platoon leader is already forward with the leader's reconnaissance, the platoon sergeant moves the platoon forward. The move from the assembly area is timed beforehand so the lead section crosses the LD at the time of attack

without halting in the attack position. If the platoon must halt in the attack position, it uses a coil or herringbone formation, dismounts infantry for security, and takes care of last-minute coordination.

c. **Line of Departure to the Assault Position.** The platoon's assault element moves from the LD to the assault position. It uses cover and concealment, and if it is detected, it uses smoke and supporting fire. The support element overmatches from positions that support the advance of the assault element. The support element leader (platoon sergeant) controls the method and rate of fire. He gives the command to open fire at the direction of the platoon leader. He must coordinate fires within the support element so that the platoon has continuous fire support.

(1) If the platoon is hit by indirect fire en route, it moves quickly out of the area. If the platoon meets enemy resistance short of the objective, platoons, squads, or sections initiate the attack. The platoon leader can have the FO call for and adjust indirect fire on the enemy. Depending on the place, the type of resistance, and the company plan, the platoon might be ordered to bypass enemy soldiers who cannot affect the mission. The platoon reports locations of all bypassed enemy to the company commander.

(2) The platoon bypasses or breaches obstacles along the route. The platoon leader decides how to best overcome the obstacle without losing the momentum of the attack. He informs the company of obstacles that can affect follow-on platoons.

d. **Assault Position to the Objective.** The assault position is the last covered and concealed position before the objective. This position should be as close to the objective as possible without being detected.

(1) Ideally, the platoon's assault element occupies the assault position without the enemy detecting any of the platoon's elements. If so, the platoon can still achieve surprise. Preparations in the assault position may include preparing bangalores, other breaching equipment, or demolitions; fixing bayonets; lifting or shifting fires; or preparing smoke pots.

(2) If the platoon is detected, as the platoon nears the assault position, the FO increases the indirect fires on the objective. The support element also increases its volume of fire. The platoon occupies the assault position if there are any last-minute preparations required. If the platoon does not need to stop, it passes through the assault position and assaults the objective. A platoon sometimes must halt to complete preparation and to ensure synchronization of all friendly forces. Once the assault element moves forward of the assault position, the assault must

continue. If stopped or turned back the assault element could sustain excessive casualties.

(3) Supporting fire must continue to suppress the enemy and must be closely controlled to prevent fratricide. At times, the assault element may mark each soldier or just the team on the flank nearest the support element. The assaulting soldiers and the support element sustain a high rate of fire to suppress the enemy. The company commander shifts or lifts indirect fire when it endangers the advancing soldiers. He coordinates this with the platoons' assaults. As the fire of the platoon's support element is masked, the platoon leader shifts or lifts it or displaces the vehicles/weapons to a position where continuous fire can be maintained.

e. **Actions on the Objective.** If destruction of the enemy is required, it may be done either by fire or close assault. Destruction by fire is preferred, because it takes advantage of the BFV's weapons systems and their long ranges. Destruction by fire limits the exposure of dismounted personnel to the enemy's fires and allows the platoon leader to better protect and conserve his dismounted infantry. If destruction cannot be accomplished by fire, an assault of the enemy position may be required, and an immediate attempt is made to locate a part of the defenses that are either incomplete or weak.

(1) **Assaulting mounted.** Assaulting mounted is only conducted against light resistance or when there are no heavy antiarmor weapons on the objective.

(a) If tanks are available, the team commander directs them to lead the assault, and BFVs support while moving. BFVs orient their turret weapons on ATGM and dismounted targets that could slow the tanks. If assaulting mounted, firing port weapons should be manned to ensure a high volume of suppressive firing during the assault. As the BFVs assault over the objective, care must be taken to ensure the bypassed enemy infantry cannot attack the tanks and BFVs with close range AT weapons.

(b) The assault should be coordinated with suppressive indirect fire, especially VT, that would not pose a threat to the tanks and BFVs. The BFV platoon should select a tentative dismount point in the event the enemy begins to place effective antitank fires on the platoon.

(2) **Assaulting dismounted.** During a dismounted assault, the mounted element, under the control of the platoon sergeant, provides a base of fire to support the dismounted element's assault onto the objective. If terrain does not support the BFV providing a base of fire for the dismounted assault, the platoon leader can use the M249s in the machine gun role as a dismounted base of fire. (See Appendix D for more

details.) If an assault position has been designated, the dismount element uses it to deploy. As little time as possible is spent in the assault position and the deployment into the assault formation should be made as rapidly as possible.

(a) When the rifle squads are on line, the platoon continues forward using fire and movement. The final assault is not a stand-up, on-line rush. In the assault, fire team leaders lead by example because it is hard for oral orders to be understood. "Follow me and do as I do" is the way to lead.

(b) Team leaders lead through the enemy positions. They move using individual movement techniques. Soldiers follow their leaders' examples. The assault may be by crawling or by short rushes from covered position to covered position. It must be aggressively done, because the dismount element cannot stop once it is near the enemy. As it fights its way through the objective (still using fire and movement), the dismount element must avoid exposing itself to fire from enemy forces behind or to the flanks of the objective. Soldiers must not bunch up because this makes them easier targets.

(c) Normally, the entire dismount element supported by BFPVs, tanks, and ITVs moves forward to assault the enemy. When their fires are not adequate to support the assault, the platoon leader may setup his own base of fire from within the dismount element.

(d) When the dismount element begins to fire and move through the objective, actions by squad leaders are key to fire distribution. Squad leaders move near the center of their squads where their own men can see them. Most of the time, they control fire by firing their own weapon into the areas where they want their men to fire. They also can use arm-and-hand signals. At times, short, easily understood oral orders can be used, but in most cases oral orders will not be heard over battle noises.

(e) Since the squad leader is near the center of his squad, he may fire his weapon to mark the center of the squad objective. Men on his right and left fire to the sides of the point where his rounds are hitting. The team leader also can use his M203 grenade launcher to mark the center of the team objective with a smoke round. (The platoon leader can assign squads a different color.) The squad leader can use tracer ammunition or have the squad automatic weapons stay with him to mark the objective.

(f) As stated earlier, squad objectives are usually specific terrain features or specific enemy positions. The type of objective influences the kind of fire distribution the leader will want to use, either point or area fire.

- When the leader's marking fire hits a bunker, firing point, or fighting position, then the team uses point fire.
- When the marking fire hits a point that cannot be identified as an enemy position, the team uses area fire.

(g) The mounted and dismounted elements strive to get a heavy volume of accurate fire on the objective, and dismounted leaders ensure their soldiers move forward aggressively. As the noise and confusion of battle makes voice control difficult, leaders move to critical points to make sure their commands are understood and carried out. They also must see that soldiers do not fire randomly and waste ammunition.

(h) Assaulting soldiers clear the enemy positions and move over the objective far enough to fire at any withdrawing enemy. When the BFVs join the dismount element on the objective, the dismount element should be prepared to support them by—

- Suppressing remaining enemy positions as the BFVs move across the objective.
- Designating firing positions for them on the far side of the objective.
- Providing flank and rear security for them once they are in position.

(i) The squads and the BFVs quickly occupy their assigned positions for consolidation to be ready for an enemy counterattack, or to remount the fighting vehicles and resume the attack after the objective is seized.

(j) To help coordinate and control the assault of two or more platoon dismount elements, the company commander designates a base platoon. The platoon leader in turn designates a base squad. Each dismount element guides on the company's base element. Squads guide on their element's base squad.

2-14. CONSOLIDATION AND REORGANIZATION

Once enemy resistance on the objective has ceased, the platoon must quickly take steps to consolidate and prepare to defend against a counterattack. Consolidation is planned and rehearsed before the attack. A consolidation method is determined before crossing the LD/LC.

a. **Consolidation.** Platoons use either the clock technique or the terrain feature technique in consolidating on the objective.

NOTE: All-round security is critical. The enemy might counterattack from any direction. The platoon leader must evaluate the terrain thoroughly.

(1) **Clock technique.** In using this method, the platoon leader designates either a compass direction or the direction of attack as 12 o'clock. He then uses clock positions to identify the left and right boundaries for squads. The platoon leader positions key weapons along the most likely avenue of approach based on his assessment of the terrain. BFVs receive the emphasis of emplacement. The majority of the platoon's firepower is with the BFVs. They should be oriented toward likely enemy armor counterattack routes and incorporated into the clock technique.

(2) **Terrain feature technique.** In a similar manner, the platoon leader identifies obvious terrain features as the left and right limits for squads. In both techniques, he ensures that squad sectors of fire overlap each other and provide mutual support for adjacent platoons. Again, BFVs receive emphasis for positioning. Adjacent platoons must be particularly aware of the BFV sectors.

b. **Reorganization.** Once platoons have consolidated on the objective, they begin to reorganize to continue the attack. Reorganization involves—

- Reestablishing command and control.
- Remanning key weapons, redistributing ammunition and equipment.
- Clearing the objective of casualties and EPWs.
- Assessing and reporting the platoon status of personnel, ammunition, supplies, and essential equipment. In general, the platoon goes through reconstitution.
- Performing after-operation PMCS on BFVs.
- Preparing for follow-on missions.

Section V

DEFENSE

Defensive operations are conducted to retain ground, gain time, deny the enemy access to an area, and destroy attacking forces. Successful defensive operations incorporate the defensive characteristics of preparation, disruption, concentration, and flexibility.

2-15. CONDUCT OF THE DEFENSE

This paragraph provides a standard sequence of events that a platoon takes in planning, preparing for, and executing defensive operations. The conduct of the defense normally follows the sequence listed below (Figure 2-49, page 2-99):

- Prepare for combat.
- Move to defensive positions.
- Establish defensive positions.
- Determine enemy intentions and locations.
- Initiate contact or actions against the enemy.
- Fight the defense.
- Reorganize.

a. **Prepare for Combat.** (For a detailed discussion of troop-leading procedure, see Section I.)

(1) The platoon leader receives the company warning or operation order.

(2) The platoon leader quickly issues a warning order.

(3) The platoon leader begins making a tentative plan.

(4) When possible, the platoon leader (and squad leaders and Bradley commanders) reconnoiter the defensive position and the route(s) to it. At a minimum, a map reconnaissance should be made.

(5) Based on his reconnaissance and any additional information, the platoon leader completes and issues his plan.

(6) The platoon sergeant ensures that all squad and section leaders check weapons, communications equipment, accessories for missing items and serviceability, preventive maintenance checks and services (PMCS) (the platoon leader spot-checks).

(7) The platoon sergeant makes sure that the platoon has POL, ammunition, food, water, and medical supplies on hand, in quantities prescribed by the platoon leader. (Squads and platoons should plan to

prestock an additional basic load of ammunition on the defensive position.)

(8) All soldiers camouflage themselves, their equipment, and vehicles to blend with the terrain.

(9) The platoon rehearses applicable drills and tasks.

(10) The platoon leader makes final inspection of weapons (bore sight, zero, and test fires weapons, if possible), equipment (include communications checks), and personnel (include camouflage).

(11) If an advance party is used, the platoon leader, platoon sergeant, and advance party leader (normally a squad leader) review advance party activities and redistribute equipment to the advance party (for example, tripods, stakes).

(12) If not already moving, the platoon leader initiates the movement of his platoon.

b. Move to Defensive Positions. The platoon applies fundamentals of movement:

(1) Do not move vehicles directly forward from covered and concealed positions.

(2) Move on covered and concealed routes.

(3) Avoid likely ambush sites.

(4) Enforce camouflage, noise, light, radiotelephone, and litter discipline.

(5) Maintain all-round security, to include air guards.

(6) Use formations and movement techniques based on METT-T.

c. Establish Defensive Positions. When an advanced party is not used, the platoon halts short of the defensive position in a covered and concealed position, and establishes local security.

(1) The platoon leader, squad leaders (Bradley commanders, if possible), and a security element conduct a leader's reconnaissance. The reconnaissance party enters the position from the rear.

(a) The leader's reconnaissance—

- Maintains security. This includes the period during the occupation of the position as well as the leader's reconnaissance.)

- Checks for enemy activity, or signs of past enemy activities, obstacles, booby traps, and NBC contamination.

- Confirms and adjusts BFV and squad positions and sectors of fire from those in the tentative plan. Normally the platoon leader assigns and adjusts machine guns and antiarmor positions. (This includes a reconnaissance forward of the positions to verify

what routes the enemy will use and how he may approach over different routes [mounted and dismounted].)

(b) The platoon occupies the designated position. Guides control the movement of the platoon into position.

(2) The platoon occupies its position. The platoon leader—

(a) Establishes security (to include OPs, hasty perimeter, or security patrols).

(b) Positions BFVs and squads, machine guns, and any attachments.

(c) Assigns sectors of fire, engagement priorities, and other fire control measures. Sites crew-served weapons.

(d) Chooses the platoon CP location.

(e) Assigns alternate and supplementary positions and routes to them.

(f) Develops an obstacle and direct-fire plan. Sites obstacles to support placement of crew-served weapons.

(g) Develops a fire support plan with the platoon FO (includes final protective fires, and fires used to support repositioning the platoon to alternate or supplementary positions).

(h) Ensures that communications have been established from the company CP and to the BFVs and squad positions. (Responsibility for establishment of communications is from higher to lower.)

(i) Confirms all positions and squad sector sketches before soldiers begin digging (includes range cards for all BFVs and antiarmor and crew-served weapons).

(j) Collects BFV and squad sector sketches and consolidates them into a platoon sector sketch. He forwards a copy to the company CP.

(k) Ensures that his platoon is tied-in with platoons on its left and right. (Responsibility for adjacent unit coordination is left to right and higher to lower.)

(1) Develops a reconnaissance and surveillance plan IAW the company plan (includes the location of PEWS).

(m) Walks positions to confirm that they meet standards.

(n) Walks forward of positions, if possible, to check camouflage and confirm dead space.

(o) Checks on wire and mine teams. The platoon leader ensures that protective wire is outside of hand-grenade range from the fighting positions. He checks to ensure that tactical wire lies along the principal direction of fire (PDF), the final protective lines (FPL), or the left and right limit of weapons.

(p) Briefs the platoon sergeant on the logistics plan (includes resupply and casualty evacuation routes).

(q) Issues platoon order and checks soldier knowledge and understanding. (All soldiers must be aware of friendly forces forward of the position; for example, patrols, reconnaissance platoons, major units, and their return routes. They must also know the signals or conditions to initiate fires, shift fires, fire FPF, and cease fires; and to reposition to alternate and supplementary positions.)

(r) Reconnoiters alternate and supplementary positions, routes into and out of the platoon position, and counterattack route, if required. (This includes good and limited visibility reconnaissance.)

(s) Plans and conducts rehearsals. The platoon rehearses the fire plan (that is, when and where to shift fires); movement to alternate and supplementary positions; counterattack; and linkup of BFVs and squads, if on separate positions.

(t) Checks the platoon reconnaissance, surveillance, and security plan, the patrol plan, and the radio watch.

(3) As time permits, the platoon continues improving the position.

d. Determine Enemy Intentions and Locations. The platoon establishes and maintains OPs. It also conducts security patrols as directed by the company commander. Patrols, OPs, and individual soldiers use eyes, ears, BFV optics and thermal sights, night surveillance devices, binoculars, PEWS, and so forth to detect the enemy approach.

e. Initiate Contact or Actions Against the Enemy. Once the enemy is detected, the platoon leader—

- Alerts the Bradley commanders, squad leaders, platoon sergeant, and his forward observer.
- Reports the situation to the company commander.
- Calls in OPs. (The squad leader or platoon leader may decide to leave the OP in place if the soldiers manning it can provide effective flanking fires, their position affords them adequate protection, or their return will compromise the platoon position.)
- Calls for and adjusts indirect fire when the enemy is at maximum range.
- Initiates the fires of his platoon on command from the company commander (long-range-fires) and IAW the company or platoon fire plan.

Leaders and individual soldiers return to their positions at the same time and prepare to fire on command from the platoon leader. (Soldiers returning to their positions may compromise the platoon location.)

They may need to stay in place rather than return or to exercise caution while returning.)

f. **Fight the Defense.** The platoon leader determines if the platoon can destroy the enemy from its assigned positions.

(1) If the answer is YES, the platoon continues to fight the defense.

(a) The platoon leader or FO continues to call for indirect fires as the enemy approaches. The platoon normally begins engaging the enemy at maximum effective range. It attempts to mass fires and initiate them at the same time to achieve surprise. Long-range fires should disrupt enemy formations; channelize him toward engagement areas; prevent or severely limit his ability to observe the location of friendly positions; and destroy him as he attempts to breach tactical obstacles.

(b) Leaders control fires using standard commands, pyrotechnics, and other prearranged signals. The platoon increases the intensity of fires as the enemy closes within range of additional weapons. Squad leaders work to achieve a sustained rate of fire from their positions by having buddy teams fire their weapons so that both are not reloading them at the same time.

(c) In controlling and distributing fires, the platoon and squad leaders consider—

- The enemy's range.
- Priority targets (what to fire at, when to fire, and why).
- Nearest or most dangerous targets.
- Shifting to concentrate fires on their own or as directed by higher headquarters.
- Ability of the platoon to engage dismounted enemy with enfilading, grazing fires, and flank shots against enemy vehicles.

(d) As the enemy closes on the platoon's protective wire, the platoon leader initiates FPF. The following actions occur at the same time.

- Automatic weapons fire along interlocking principal directions of fire (PDF) or FPLs. Other weapons fire at designated PDF. The M203 grenade launchers engage enemy in dead space or against enemy attempts to breach protective wire.
- The platoon continues the fight with Claymore mines and hand grenades.
- If applicable, the platoon leader requests indirect FPF in support of his positions.

(e) The platoon continues to defend until the enemy is repelled, or the platoon is ordered to disengage.

- (2) If the answer is NO, the platoon leader—
- (a) Reports the situation to the company commander.
 - (b) Continues to engage the enemy as the designated company support element, or repositions the platoon (BFVs and or squads of the platoon) as directed by the company commander to—
 - Continue fires into the platoon sector (engagement area).
 - Shift to alternate or supplementary positions.
 - Reinforce other parts of the company.
 - Counterattack locally to retake lost fighting positions.
 - Withdraw from an untenable position using fire and movement to break contact. (The platoon leader should not move his platoon out of position if it will destroy the integrity of the company defense.)

NOTE: In any movement out of a defensive position, the platoon must employ all direct and indirect fire means available to suppress the enemy long enough for the platoon to move.

g. **Reorganize.** The platoon remains key weapons, reestablishes security, provides first aid and prepares wounded soldiers for evacuation, and redistributes ammunition and supplies. The platoon relocates selected weapons to alternate positions if leaders believe that the enemy may have pinpointed them during the attack and adjusts other positions to maintain mutual support. The platoon also reestablishes communications. It reoccupies and repairs positions, and prepares for renewed enemy attack. The platoon repairs damaged obstacles and replaces mines and booby traps.

(1) Squad and section leaders provide ammunition, casualty, and equipment (ACE) reports to the platoon sergeant. Bradley commanders also provide fuel status. The platoon sergeant consolidates the ACE reports, reviews his ACE report with the platoon leader, and forwards it to the company commander (or XO).

(2) The platoon leader reestablishes the platoon chain of command.

(3) The platoon sergeant coordinates for resupply and supervises the execution of the casualty and EPW evacuation plan.

(4) The platoon continues to improve positions. The platoon quickly reestablishes OPs and resumes patrolling as directed.

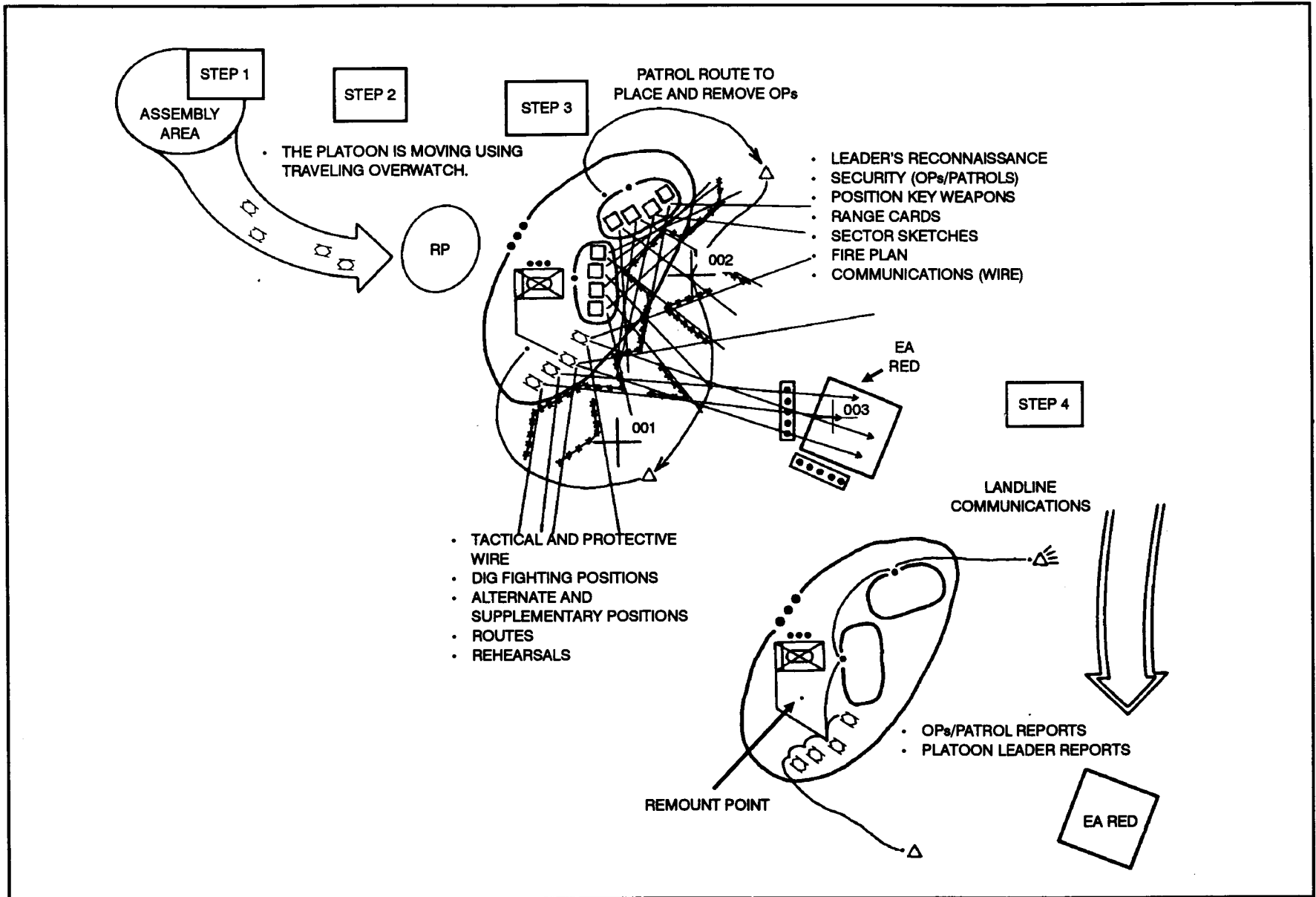

Figure 2-49. Platoon defend.

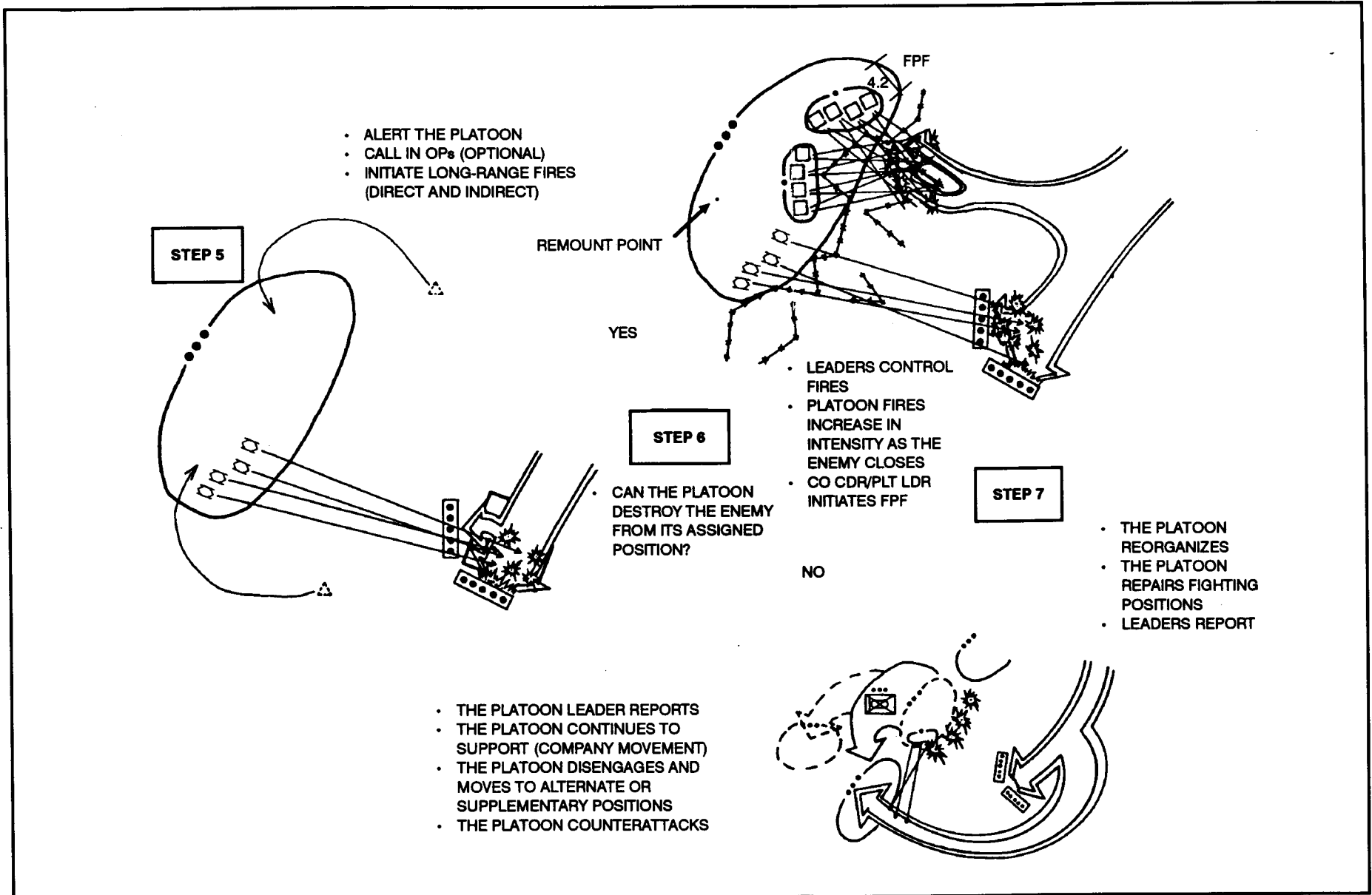

Figure 2-49. Platoon defend (continued).

2-16. DEFENSIVE TECHNIQUES

The techniques used by platoons to perform assigned missions and functions are as follows.

a. **Defend a Battle Position.** A platoon defends from a battle position to concentrate its fires, limit its maneuver, or place it in an advantageous position to counterattack. The basic methods of employing the platoon are same battle position, same avenue of approach; same battle position, different avenues of approach; different battle position, same avenue of approach; different battle positions, different avenues of approach.

(1) BFVs and dismounted infantry on the *same* battle position covering the *same* avenue of approach. (Figure 2-50.)

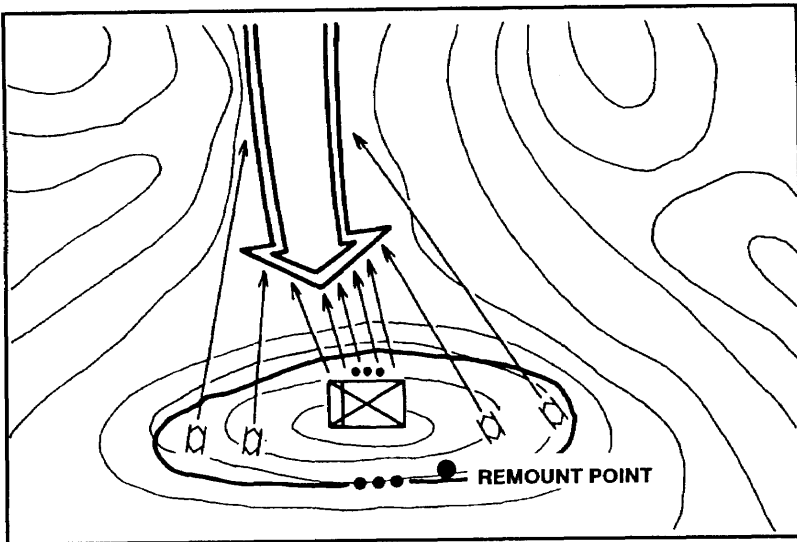

Figure 2-50. Same battle position, same avenue of approach.

(a) Using this method, the platoon can defend against mounted and dismounted attacks and move rapidly to another position. However, because of the differences in capability of the dismounted and mounted element, use of this technique usually prevents the most effective use of either element.

(b) Within the battle position, the BFV may be positioned with the squads forward or around the vehicles for security.

(c) The BFVs remain on the same battle position as the squads when the terrain provides good observation, fields of fire, and cover and concealment to both dismounted infantry and BFVs.

(d) Employing both elements of the Bradley platoon on the same battle position covering the same avenue of approach is the most conservative use of the Bradley platoon. Its primary advantages are—

- Facilitates command and control functions within the platoon because of the proximity of both the vehicle and dismount elements as well as their orientation on the same approaching enemy.
- Facilitates remounting of vehicles.
- Provides increased security for BFVs because of the proximity of friendly dismounted troops.

(2) BFVs and dismounted infantry on the *same* battle position covering *different* avenues of approach. (Figure 2-51.)

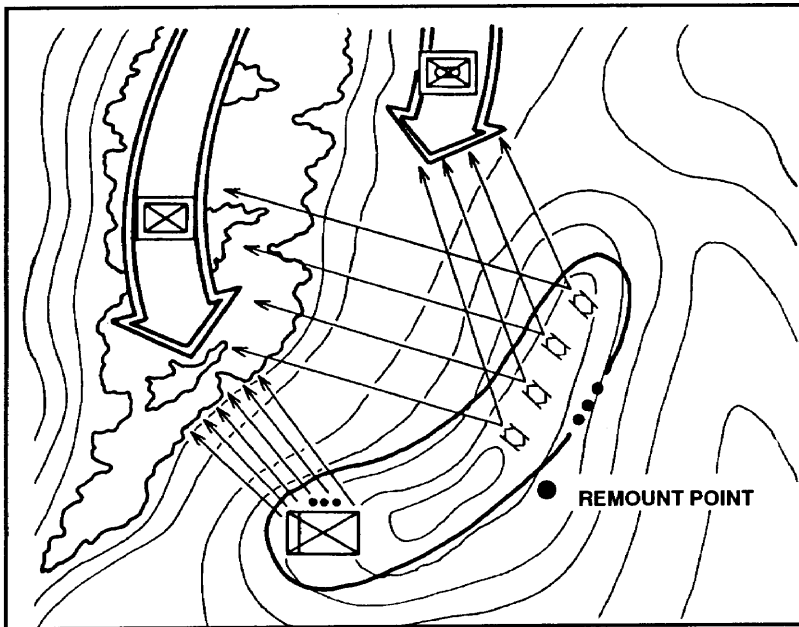

Figure 2-51. Same battle position, different avenues of approach.

(a) When the battle position has two equally dangerous avenues of approach, one with long-range and one with short-range fields of fire, the fighting vehicle element is positioned to take advantage of its long-range fires, and the dismount element is placed for short-range fires. This allows good positioning of the fighting vehicle element and the dismount element because each is positioned on terrain best suited to its capabilities. During reduced visibility, the platoon leader often directs repositioning of some of the dismounted element to provide adequate local security for the BFVs.

(b) Plans must be made to shift BFVs if a dismounted avenue of approach becomes the most dangerous and the mounted is ignored by the enemy.

(3) BFVs and dismounted infantry on *different* battle positions covering the *same* avenue of approach. (Figure 2-52.)

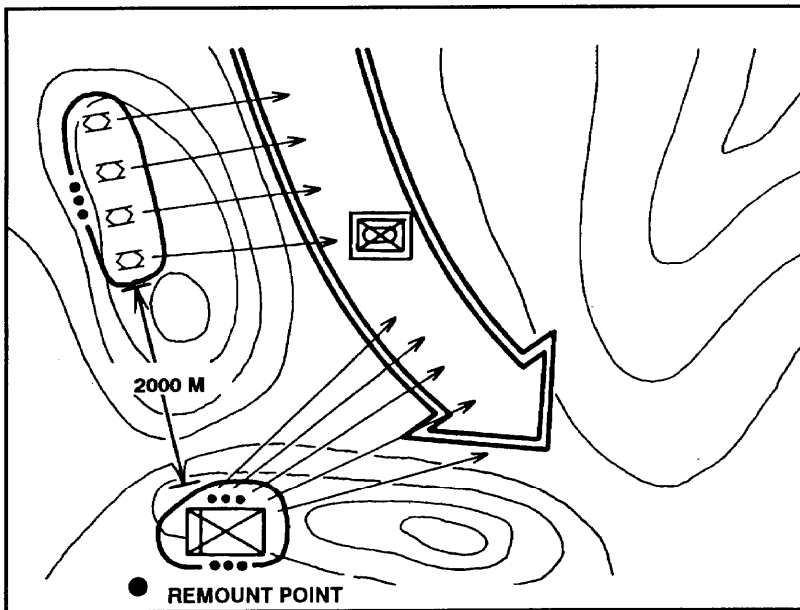

Figure 2-52. Different battle positions, same avenue of approach.

(a) If positioned on separate battle positions, BFVs and dismounted infantry must fight in relation to each other when covering the same avenues of approach. This means BFVs can provide the dismounted

infantry with supporting fires from their primary, alternate, or supplementary positions. Both elements are positioned to engage enemy forces on the same avenue of approach, but at different ranges. There are basically three techniques to accomplish this.

- The *first technique* is to place the dismounted infantry close enough to the engagement area to employ all dismounted weapons. The BFVs are placed in depth to enhance the antiarmor fires and engage the enemy formation in depth. This technique enables the platoon to mass all its fires.
- The *second technique* is to place the BFVs to engage the enemy in a specific EA and place the dismounted infantry in the most probable route for enemy infantry to use once the BFVs force them to dismount. This technique allows the platoon to take advantage of the BFVs' long-range firepower. The disadvantage is that dismounted infantry may not get into the fight, and all the platoon's firepower is not massed.
- The *third technique* is especially useful in restrictive terrain. Dismounted infantry is placed in choke points and BFVs are placed to support the infantry by destroying enemy armor as they seek to bypass, by engaging in a supplemental EA, or by firing into the same EA as the dismounted infantry.

A planning figure for separation of the mounted and dismounted elements is a maximum of three fourths of the effective range (about 1,500 meters) of the BFV's primary armament—the 25-mm gun.

(b) The fighting vehicle element can be employed forward of the dismounted element on the same avenue of approach. This allows for better observation and fields of fire, and better use of the BFV's weapons (Figure 2-53).

(c) The dismount element should use available time to prepare fighting positions and obstacles. When the enemy attacks, BFVs normally engage enemy formations and, at a prearranged signal or event, move to alternate positions to the flank or to the rear of the dismount element. The timing of this move is critical. While maximum advantage can often be gained by employing the fighting vehicle element forward, the vehicles become more vulnerable to enemy fire as the enemy closes.

(d) The leader of the dismount element must be able to conduct operations without the support of the BFVs. The quantity and type of weapons, ammunition, mines, equipment, and supplies for the dismount element must be considered.

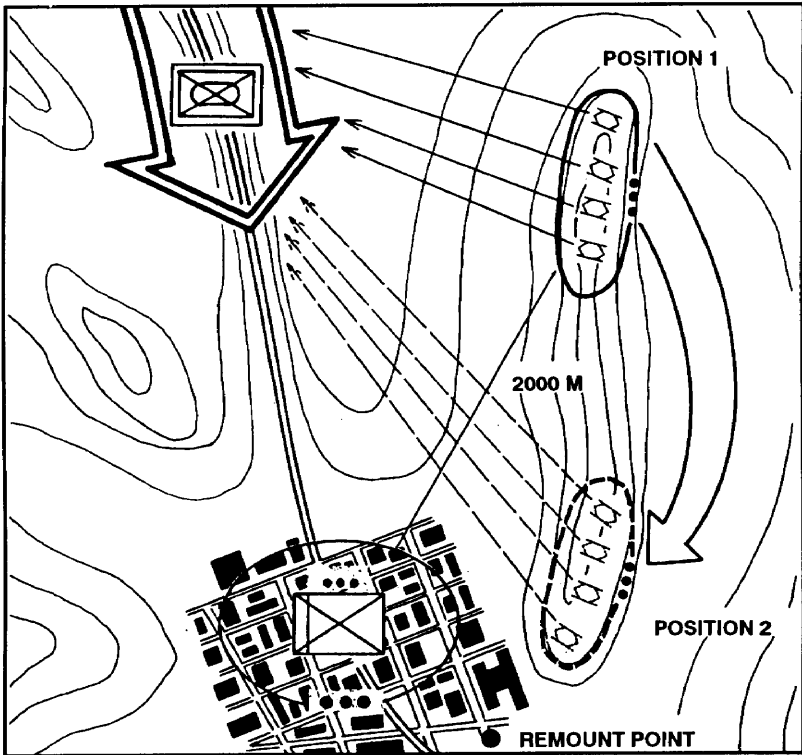

Figure 2-53. Bradleys displacing to support dismount element.

(e) BFVs may be employed well forward to perform a specific task; that is, a screen or guard. A section with a squad can also conduct security operations. Normally, this is done under the direction and control of the company/team commander.

(4) BFVs and dismounted infantry on *different* battle positions and *different* avenues of approach. When a Bradley platoon's mounted and dismounted elements are not going to be fighting in relation to each other, the control of both elements should be consolidated at company team level using the company team executive officer. The commander may consolidate dismount elements in one location and deploy the platoon's BFVs separately in the following situations:

(a) A large number of dismounted soldiers are required to hold a position, for example, key terrain.

(b) Primary positions for the dismount element do not allow adequate fields of fire for the BFV's weapon.

(c) The dismount element must occupy heavily wooded or rugged terrain that the BFV cannot traverse.

(d) When both a mounted and dismounted avenue of approach must be defended and the terrain cannot be defended from the same battle position.

b. Defend in Sector. A platoon defends in sector to prevent enemy forces from passing the rear boundary of the sector, retain flank contact and security, and ensure unity of effort with the company scheme of maneuver. The defense in sector maximizes the combat abilities of the platoon. It allows the platoon to fight throughout the depth of the sector using dispersed small-unit tactics.

(1) The platoon is usually assigned a sector within the company sector (Figure 2-54). The platoon leader may in turn assign sectors to elements, sections, and squads to permit maximum freedom of action for them to defend. They call for fire support through the platoon net. FOs may be attached or, as a minimum, leaders must be prepared to assist in calls for supporting fires.

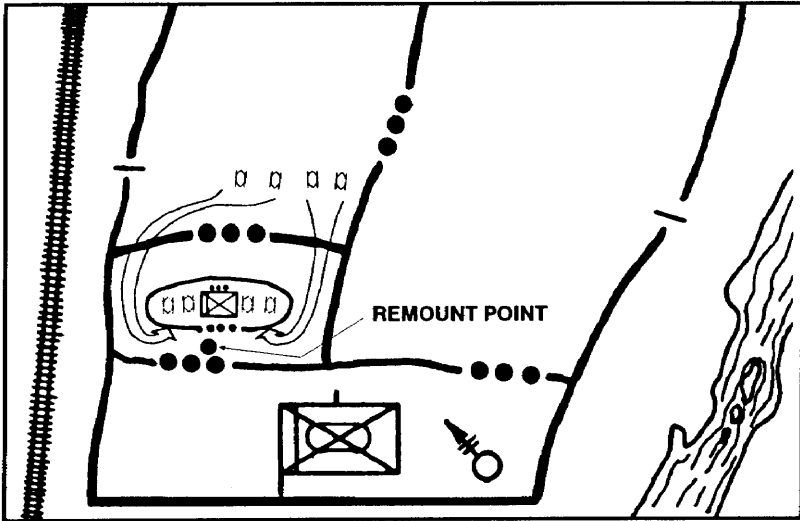

Figure 2-54. Assigned sectors.

(2) All elements (mounted/dismounted) coordinate with each other and conduct detailed reconnaissance of each sector and identifies all likely enemy avenues of approach, choke points, kill zones, obstacles, patrol bases, and cache sites. They also identify all tentative positions.

(3) The platoon leader confirms the selected tentative sites and incorporates them into his concept (Figure 2-55). He designates initial positions and the sequence in which successive positions are to be occupied. He gives each element specific guidance concerning contingency plans; rally, mount, and dismount points; and other coordinating instructions.

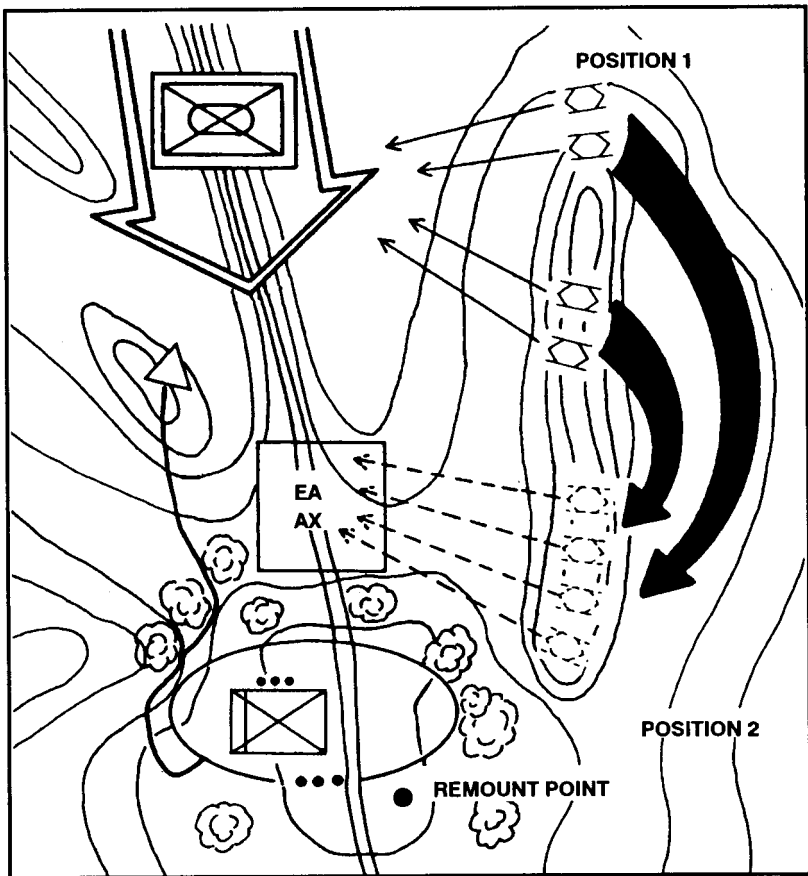

Figure 2-55. Concept of the operation for a defense in sector.

(4) All elements then prepare the defense in the sequence designated by the platoon leader. They initially prepare the primary position and then a hasty supplementary position, and then they select the alternate position. Elements improve the positions as time permits.

(5) When security warns of approaching enemy, the squad and section occupy their primary positions and prepare to engage the enemy. As the enemy moves into the choke point or kill zone, the squad and section initiates an ambush. They engage the enemy targets only as long as squads and sections do not become decisively engaged. Squads and sections then move to their next position and repeat the same process. The leader must plan the disengagement. Supporting positions, the use of smoke, and rehearsals are key to effective disengagements. Depending on METT-T factors, the entire battle may be fought this way. Some variations of this technique include the following:

(a) Allowing the enemy to exhaust himself reacting to numerous ambushes, then conducting a violent counterattack along previously rehearsed routes to complete the destruction of the enemy. The platoon leader can do this by retaining direct control over a large portion of the platoon and committing it at the decisive moment. An alternative is to use prearranged signals to consolidate the platoon at a rally point; then to conduct the counterattack.

(b) Having the forward ambush teams hold their fire until the lead elements of the enemy formation hit another ambush deeper in the sector. Then the team ambushes the next enemy element as it passes through the kill zone. This technique destroys the cohesion of the enemy and is especially effective if the ambush eliminates the command group of the enemy unit.

(c) Planning indirect fires to cause more enemy casualties at ambush sites along a well-defined route.

(6) Casualty evacuation and resupply of ammunition and water are particularly difficult when defending this way.

c. **Defend a Strongpoint.** Defense of a strongpoint is seldom used by mechanized forces. When a platoon defends a strongpoint, it must retain the position at all costs until ordered to withdraw. (Figure 2-56.) A platoon uses a strongpoint to accomplish one of the following:

- Hold key or decisive terrain critical to the company or battalion scheme of maneuver.
- Provide a pivot point for the maneuver of friendly forces.
- Block an avenue of approach.
- Canalize the enemy into friendly engagement areas.

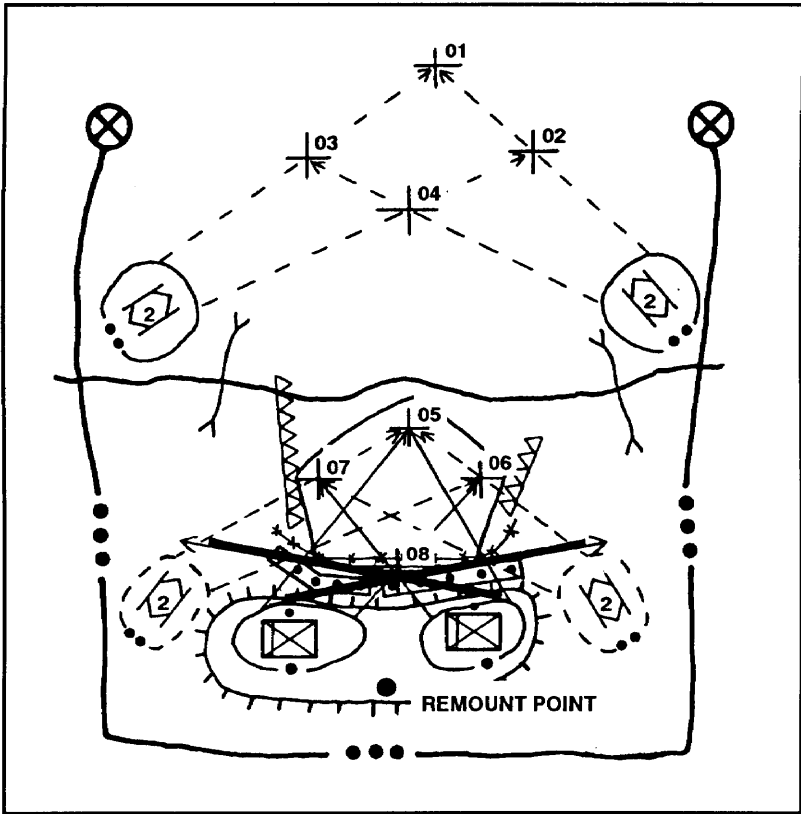

**Figure 2-56. Defending a strongpoint
(BFVs outside a strongpoint).**

d. **Defend a Perimeter.** The major advantage of the perimeter defense (Figure 2-57, page 2-110) is the preparedness of the platoon to defend against an enemy avenue of approach. A perimeter defense differs from other defenses in that—

- The trace of the platoon is circular or triangular rather than linear.
- Unoccupied areas between squads and vehicles are smaller.
- The flanks of the squads and sections are bent back to conform to the plan.
- The bulk of combat power is on the perimeter.
- The reserve is centrally located.

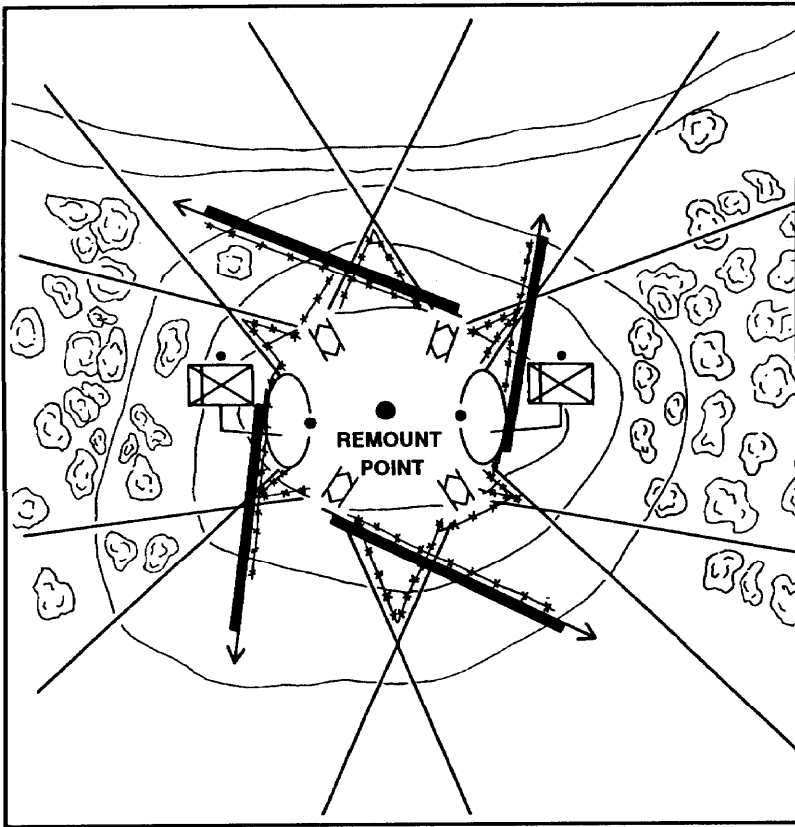

Figure 2-57. Perimeter defense.

e. **Defend on a Reverse Slope.** The estimate of the situation often leads the commander to employ his elements, especially his dismounted infantry, on the reverse slope: If the dismounted infantry are on a mounted avenue of approach, the dismounted infantry must be concealed from enemy direct-fire systems, which they cannot effectively engage. This means dismounted infantry should be protected from enemy tanks and observed artillery fire. This applies even when friendly forces are fighting with their tanks and long-range ATGMs. (Figure 2-58.)

(1) The majority of dismounted infantry weapons are not effective beyond 600 meters. In order to reduce or preclude destruction from enemy direct and indirect fires beyond that range, a reverse-slope defense should be considered.

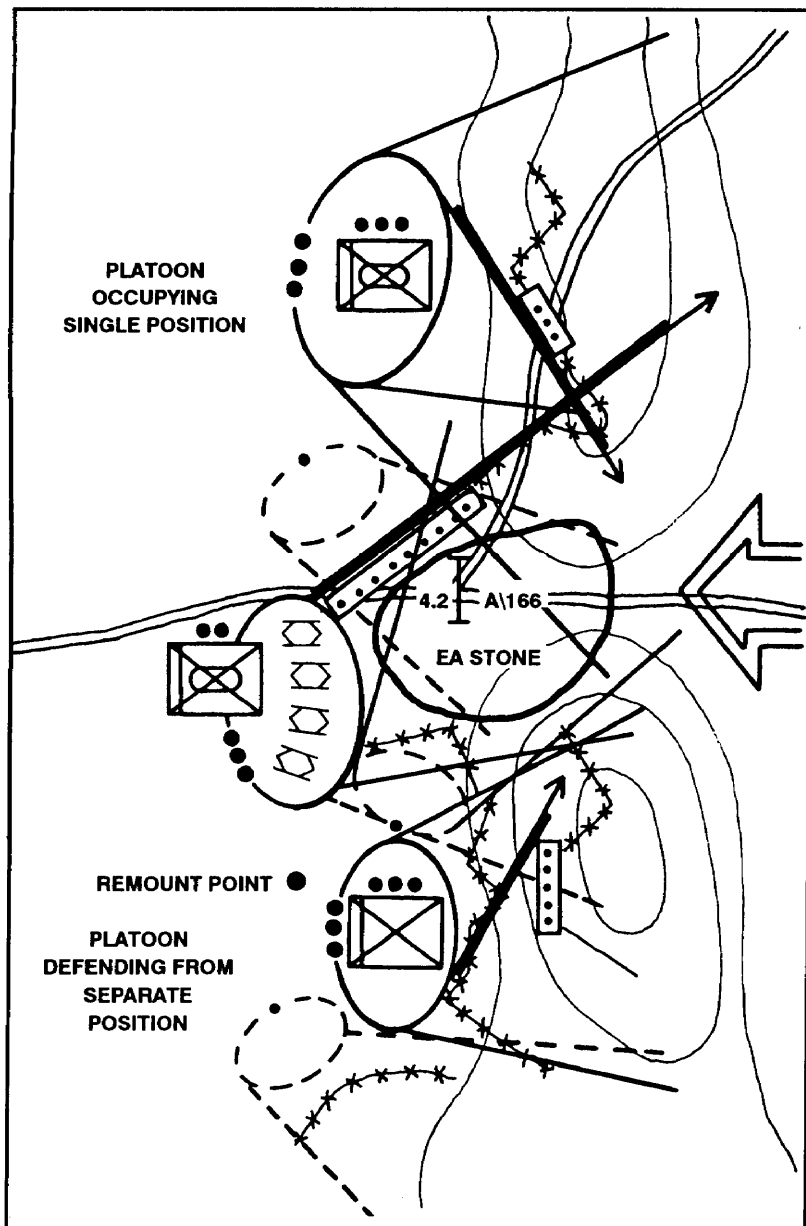

Figure 2-58. Reverse-slope defense options.

(2) This conflicts, to some extent, with the need for the maximum observation forward to adjust fire on the enemy as well as the need for long-range fields of fire for friendly tanks, BFVs, and ATGMs. In some cases, it may be necessary for tanks, BFVs, and ATGMs to be deployed forward while the dismounted infantry remain on the reverse slope. These vehicles withdraw from their forward positions as the battle closes. The vehicles' new positions should be selected to take advantage of the BFV's long-range fires to get enfilade shots from the depth and the flanks of the reverse slope.

(3) At night, the nature of the threat may change and dismounted infantry may occupy the forward slope or crest to deny it to the enemy. In those circumstances, it is feasible for a dismounted element to have an alternate night position forward.

(4) The area forward of the topographical crest must be controlled by friendly forces through aggressive patrolling and active as well as passive reconnaissance means. The platoon should use all of its night vision devices to deny the enemy undetected entry into the platoon's defensive area. The BFVs area key part of the platoon's surveillance plan and should be positioned to take advantage of its thermal sights. The enemy must not be allowed to take advantage of reduced visibility to advance to a position of advantage without being taken under fire.

(5) Advantages of a reverse-slope defense are—

- Enemy ground observation of the position, including the use of surveillance devices and radar, is masked.
- Enemy cannot engage the position with direct fire without coming within range of the defender's weapons.
- Enemy indirect fire will be less effective due to lack of observation.
- Enemy may be deceived about the strength and location of positions.
- Defenders have more freedom of movement out of sight of the enemy.

(6) Disadvantages of a reverse-slope defense are—

- Observation to the front is limited.
- Fields of fire to the front are reduced.
- Enemy can begin his attack from a closer range.

(7) The decision to position forces on a reverse slope is normally made by the commander. He positions forces on a reverse slope when—

- He wishes to surprise or deceive the enemy about the location of his defensive position.

- A forward slope might be made untenable by direct enemy fire.
- Occupation of the forward slope is not essential to achieve depth and mutual support.
- The fields of fire on the reverse slope are better or at least sufficient to accomplish the mission.
- The forward slope position is likely to be the target of concentrated enemy artillery fires.

(8) BFVs offer the platoon additional opportunities regarding positioning. They can initially be positioned forward to take advantage of their protection from artillery and their ability to engage the enemy at long ranges. After an initial engagement, BFVs may move over or around the crest line and through the dismounted infantry on the reverse slope to a position that is either on the flanks or farther in depth to the rear.

(9) Obstacles are also necessary in a reverse-slope defense. Since the enemy will be engaged at close range, obstacles should—

- Prevent the enemy from closing too quickly and overrunning the positions.
- Facilitate disengagement.

2-17. BASIC TACTICS

The turret weapons of the BFV allow it to fight against the enemy, while the dismounted infantry are used in restrictive terrain to their best advantage.

a. Bradley-equipped platoons can fix or substantially limit the movement of the attacking enemy, thus allowing tanks to deliver a powerful counterattack.

b. The fixing of the enemy—denying him the ability to withdraw part of his force for employment elsewhere—is done by BFVs using their firepower and maneuverability. At the same time, the dismounted infantry digs in on restrictive terrain or on a reverse slope and fully exploits the advantage of the defender to prepare the battlefield. On dismounted avenues of approach, the platoon leader can use the M249 in the machine gun role to fix the enemy and make use of its heavy firepower in the final protective fire. (See Appendix D for more detail.)

c. The BFV's antiarmor and antipersonnel firing systems combined with its survivability are optimized through the use of movement, cover and concealment, dispersion, mutual support, flank shots, and employment in depth.

2-18. PRIORITY OF WORK

The priority of work is the leader's method of controlling the preparation of the defense. Each duty position should have its own priority of work. The leader adjusts the priority of work based on METT-T factors and on his intent for the operation. (See Chapter 4, SOP, Annex C for more information.)

a. Platoon Leader.

- Establish local security. He may setup OPs, a hasty perimeter, or conduct security patrols.
- Conduct leader's reconnaissance with his squad leaders (BC if possible).
- Position BFVs, squads, Dragons, machine guns, and any attachments.
- Choose the CP location.
- Assign alternate and supplementary positions.
- Assign sectors of fire, engagement priorities, and other fire control measures.
- Develop an obstacle and fire plan.
- Develop a fire support plan (with the FO).
- Check the CP.
- Brief the platoon sergeant on logistics.
- Verify communications to higher and lower units.
- Make a sector sketch and send one copy to the commander IAW the platoon SOP.
- Confirm all positions (before digging starts) to include interlocking fires.
- Coordinate with left and right units.
- Direct the location for the PEWS.
- Check positions and preparations constantly. Look at them from the enemy's point of view; immediately correct deficiencies.
- Check soldiers' knowledge.
- Check dead space.
- Check security.
- Reconnoiter routes to and from alternate and supplementary positions, and routes used on a counterattack. Brief squad leaders and Bradley commanders.
- Plan and conduct rehearsals of movement to and between primary, alternate, and supplementary positions.

- Check the security and alert plan, the patrol plan, the radio watch, and the logistics.
 - Rehearse the counterattack plan.
 - Supervise.
- b. **Platoon Sergeant.**
- Set up the M8 chemical alarm.
 - Establish the platoon CP (and alternate CP); lay wire to squads, BFVs, OPs, attached elements, MAWs, and machine guns.
 - Send runner to guide wire from company to platoon.
 - Supervise the emplacement of BFVs, squads, MAWs, and machine guns.
 - Supervise preparation of range cards.
 - Request and allocate pioneer tools, barrier material, rations, water, batteries, and ammunition.
 - Help the platoon leader prepare the sector sketch.
 - Set up ammunition resupply point.
 - Set up EPW collection point.
 - Set up casualty collection point.
 - Coordinate medical support to include supplies for platoon aidman and combat lifesaver.
 - Designate latrine area and supervise the digging of the platoon slit trench.
 - Establish the security and alert plan, the radio watch, the sleep plan, and the PMCS schedule; brief the platoon leader.
 - Rest and conduct personal hygiene.
 - Supervise.
- c. **Bradley Commander.**
- Position BFV.
 - Establish security (driver, gunner, or BC mans turret weapons system at all times unless told otherwise).
 - Coordinate with left and right BFV and squad.
 - Prepare range card.
 - Boresight turret weapons system.
 - Ensure wire is laid to the BFV.
 - Issue rations, water, ammunition, pioneer tools, and barrier materials.
 - Pass additional information and changes to plans.

- Reconnoiter alternate and supplementary positions.
- Conduct maintenance on BFV.
- Supervise.

d. **Squad Leader.**

- Establish local security.
- Ensure wire is laid to squad and BFV.
- Position squad, weapons, and soldiers; and assign sectors of fire.
- Ensure soldiers manning the OP have a position to return to.
- Draw a squad sector sketch and submit copy to platoon leader.
- Walk the position. Check sectors of fire, range cards, aiming stakes, and dead space by getting into each position and sighting weapons.
- Coordinate with left and right squad and BFV.
- Have soldiers begin digging after platoon leader checks position.
- Issue rations, water, ammunition, pioneer tools, and barrier material.
- Pass additional information and changes to plans.
- Supervise wire or mine teams.
- Give a warning order for planned patrol missions.
- Set up squad alert and security plan.
- Reconnoiter alternate and supplementary positions, routes, and counterattack plan with the platoon leader, then brief team leaders.
- Designate squad urine areas.
- Post and brief OPs.
- Rest and conduct personal hygiene.
- Supervise.

e. **Team Leader.**

- Assist the squad leader as directed.
- Supervise.

2-19. WEAPONS EMPLACEMENT

The success of the defense depends on the positioning of soldiers and weapons. To position their weapons effectively, all leaders must know the characteristics, capabilities, and limitations of their weapons, the effects of terrain, and the tactics used by the enemy. Platoon leaders should position weapons where they have protection; avoid detection; and surprise the enemy with accurate, lethal fires. In order to position the

weapon, the platoon leader must know where he wants to destroy the enemy and what effect he wants the weapon to achieve. Additionally, the platoon leader must consider whether his primary threat will be armored vehicles or dismounted infantry. His plan should address both mounted and dismounted.

a. **Individual BFVs.** Leaders must position BFVs where flank engagements will occur. This means placing fighting positions on the flank of enemy avenues of approach.

(1) BFVs use defilade positions when in the defense. Defilade positions are classified as either turret-down or hull-down. A turret-down position uses terrain to mask most of the BW, with only the ISU exposed to the Threat. Because the TOW, when erected, is above the ISU, it may be fired from this position without exposing more of the BFV than necessary as long as the missile has 18 inches of clearance. Targets cannot be engaged with the 25-mm from this position. A hull-down position exposes only as much of the BFV as needed to engage targets with the three primary weapon systems.

(2) Flank positions in restrictive terrain provide windows of opportunity to engage the enemy and afford the BFV additional protection from enemy overmatching fire. (Figure 2-59, page 2-118.) The basis for this technique is to limit exposure by deliberately restricting a BFV's sector of fire. The BFV is exposed only to the targets at which it is firing. It then shifts to other firing positions as targets are destroyed. These positions restrict observation and vulnerability to only one segment of the platoon's engagement area; therefore, only those targets that can be seen (and engaged) by the BFV can return fire.

(a) Use a hide position when possible and stay in it until the enemy is in the area where the platoon plans to kill him. A prone or dug-in observer forward gives a much smaller signature than a BFV.

(b) Have a backdrop and avoid anything that catches the eye.

(c) Position to the flank of an enemy approach and behind frontal cover. It is far easier for an attacker to acquire and kill targets to his front than those to his flank or rear.

(d) Use covered routes into and out of firing positions.

(e) Use a guideline of 75 meters or more between primary and alternate BFV positions.

(f) Do not construct berms. More than 20 feet of dirt is needed to be effective. They also make it easier for the attacker to spot the position.

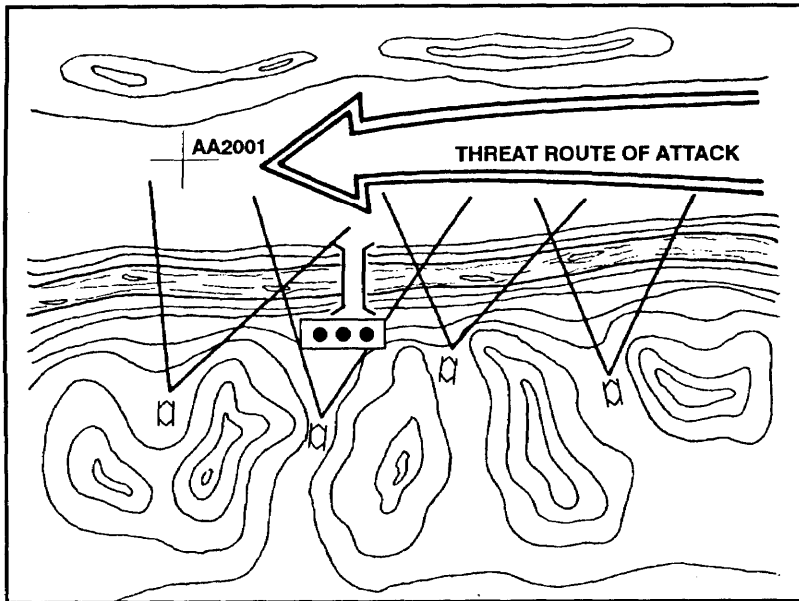

Figure 2-59. Flank positions.

(g) Avoid positions that expose weapons to large numbers of enemy systems. It is best to hide weapons from the major portion of the enemy formation. The weapon should be able to engage one or two of the enemy vehicles at a time. It must be able to shift its sector of fire to engage other portions of the enemy's formation. (Figure 2-60.)

(3) Battlefield dust, smoke, fog, and darkness normally limit observation and fields of fire. When engagement ranges are reduced, flanking fires, use of obstacles, mutual support with infantry, and covered and concealed positions increase in importance. Because of battlefield obscuration, weapons must be positioned to fight during limited visibility or be able to quickly move to limited visibility positions.

b. Dragon Methods of Employment. The platoon leader's assessment of the tactical situation governs Dragon employment. Based on the situation, the platoon leader may employ all four Dragons, or none at all. He has two options open to him for their employment—centralized or decentralized control.

- *Centralized Control.* The platoon leader controls the fires of his Dragon gunners, either by physically locating the weapons in his vicinity, and personally directing their fires, or by grouping them

together under the control of the platoon sergeant or another individual the platoon leader designates.

- *Decentralized Control.* Dragon gunners operate with, and are controlled by their squad leaders. The squad leader may need to employ one fire team as a Dragon team. The platoon leader normally gives the command for opening fire.

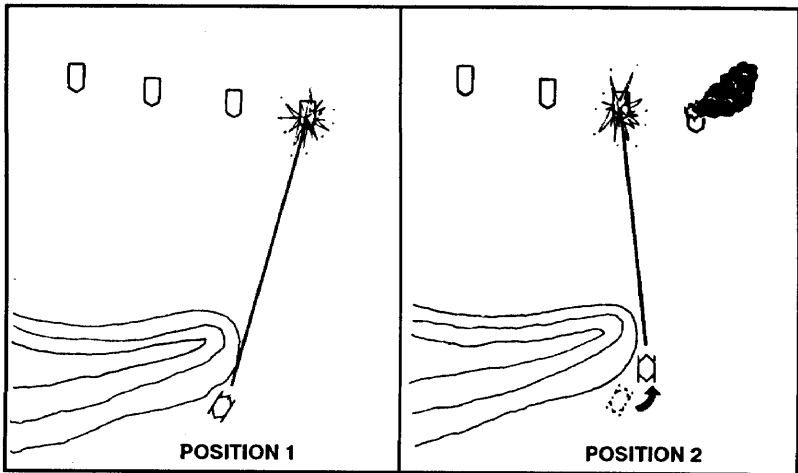

Figure 2-60. Hidden position with smaller fields of fire.

(1) **Firing position.** Firing positions must cover the armor avenue(s) of approach in the platoon's sector. The desirable characteristics of a Dragon firing position are—

- Gunner observation of assigned sector to maximum range of weapon (if possible).
- Good fields of fire.
- Cover and concealment.
- Mask clearance.
- Security.
- Concealed routes.
- Capability for flanking fires.
- Backblast area.

(2) **Fields of fire.** The gunner must be able to keep the target in the sight of the weapon until the missile impacts. Hilly and wooded terrain could permit the target to become masked during tracking, causing the gunner to lose sight of and miss the target.

(3) **Cover and concealment.** The major vulnerability of the Dragon is the gunner's exposure to enemy direct and indirect fires while tracking the missile. A position detected by the enemy is easily destroyed. Cover is protection from enemy fire. Items used for cover include walls, trees, logs, and sandbags. Concealment is denial of observation by the enemy, both ground and air. Of primary importance is the backblast or launch signature effect of the missile when launched. Every effort must be made to prevent the enemy from detecting the launch signature. This is done by clearing away all loose sticks and rocks behind the launcher, wetting down the backblast area, and engaging from the flanks and rear. Excess movement in the position must be avoided to prevent detection. Overhead cover is difficult to provide because of the clearance required for the Dragon's backblast. Overhead cover should still be constructed based on this requirement and improved as time permits. Overhead cover is vitally important to prevent detection by air.

(4) **Routes.** The Dragon gunner must have routes to displace from primary to alternate and supplementary positions in the defense. Routes into, out of, and between positions must provide good cover and concealment, and facilitate speed of movement.

(5) **Mutual support.** Firing positions should provide for mutual support with other Dragons and TOW. Fields of fire should overlap and be carefully integrated.

(6) **Security.** Provisions should be made to provide security for Dragon gunners to the front, flanks, and rear. Such security could include protective mines, OPs, RSTA devices, and individual fighting positions.

(7) **Target engagement.** Leaders must specify to Dragon gunners, either in their plans and orders, or by platoon SOP, target priorities and rules for engaging multiple targets. Dragon gunners should be assigned sectors of fire to preclude more than one weapon engaging the same target at the same time. When engaging targets, gunners ensure they can track the target until impact.

(8) **Oblique fire.** Whenever possible, gunners engage targets with oblique fire. Platoon and squad leaders, when selecting positions, try to emplace the gunner in a position that permits him to cover his sector with oblique fire. It is difficult for the enemy to retrace the flight path

of a missile to its launch site when the missile moves obliquely across their front, as opposed to being launched from a head-on position. Forces generally orient to their front and are therefore more vulnerable to fires from their flanks.

c. **Machine Gun Emplacement.** These are the platoon's main weapons and are positioned first if the enemy is a dismounted force. Once the machine guns are sited, the leader positions riflemen to protect them. The guns are positioned to place fire on the locations where the platoon leader wants to concentrate combat power to kill the enemy. (See Appendix D.)

(1) The M249 is the main weapon for the squad's defense. The squad leader positions the M249 to accomplish the squad's mission. It provides a high volume of lethal, accurate fires to break up and stop enemy assaults. The M249 is effective at forcing enemy armor to fight buttoned up. It also provides limited effects against lightly armored vehicles.

(2) Each gun is given a primary and secondary sector of fire. Their sectors of fire should overlap each other and those of adjacent platoons. A gunner fires in his secondary sector only if there are no targets in his primary sector, or when ordered to do so. Each gun's primacy sector includes an FPL or a PDF. The gun is laid on the FPL or PDF unless engaging other targets. When FPFs are called for, the gunner shifts to and engages on the FPL or PDF.

(a) **Final protective line.** Where terrain allows, the platoon leader assigns a machine gun an FPL. The FPL is a line along which grazing fire is placed to stop an enemy assault. Grazing fire is no more than 1 meter above the ground (about hip high). The FPL is fixed in elevation and direction. FPLs are used best in conjunction with an obstacle to slow, delay, or stop the enemy. If possible, FPLs should overlap. Dead space in an FPL is covered by Claymore mines or M203 fire. Assistant gunners or squad leaders walk the FPL if time permits.

(b) **Principal direction of fire.** When the terrain does not lend itself to an FPL, the platoon leader assigns the machine gun a PDF (Figure 2-61, page 2-122). The gun is positioned to fire directly down this approach rather than across the platoon's front.

(c) **Dead space.** A soldier walks the FPL to find dead space. The gunner watches the soldier walking down the line and marks spaces that cannot be grazed. The dead space is covered by obstacles, grenade launcher fire, or mines.

d. **Grenade Launchers.** The M203 is the squad leader's indirect fire weapon. He positions it to cover dead space in the squad's sector, especially the dead space for the machine guns. The M203 gunner is also assigned a sector to cover with rifle fire. The high-explosive,

dual-purpose (HEDP) round is very effective against lightly armored vehicles such as the BMP-1 and the BTR.

e. **Automatic Rifles.** The leader assigns positions and sectors of fire to each rifleman in the platoon. Normally, he positions the riflemen to support and protect the machine guns and antiarmor weapons. They are also positioned to cover obstacles, provide security, cover gaps between platoons and companies, or provide observation.



Figure 2-61. Principal direction of fire.

2-20. RANGE CARDS

A range card is a sketch of a sector that a direct fire weapon system is assigned to cover. (A reproducible Standard Range Card [DA Form 5517-R] is in FM 7-8.) A range card aids in planning and controlling fires, aids the crew in acquiring targets during limited visibility. It is also an aid for replacement personnel or platoons or squads to move into the position and to orient on their sector. During good visibility, the gunner should have no problems maintaining orientation within his sector. During poor visibility, he may not be able to detect lateral limits. If the gunner becomes disoriented and cannot find or locate reference points or sector limit markers, he can use the range card to locate the limits. The gunner should make the range card so that he becomes more familiar with the terrain in his sector. He should continually assess the sector and if necessary update his range card.

a. **Description.** To prepare a range card, the gunner must know the following.

(1) **Sectors of fire.** A sector of fire is a piece of the battlefield for which a gunner is responsible. He may be assigned a primary and a

secondary sector. Leaders use sectors of fire to ensure that fires are distributed across the platoon's area of responsibility.

(a) A sector of fire is assigned to cover possible enemy avenues of approach. Leaders should overlap sectors to provide the best use of overlapping fire and to cover areas that cannot be engaged by a single weapon system.

(b) The leader assigns left and right limits of a sector using prominent terrain features or easily recognizable objects, for example, rocks, telephone poles, fences, or emplaced stakes. The gunner should index the TOW into the ISU. This reticle position does not induce superelevation into the fire control system to find the left and right limits. Superelevation causes changes in the field of view between APDS-T, HEL-T, and coax when ammunition and range changes are selected. Using the TOW reticle also allows the gunner to scan his sector without making ammunition and range changes during scanning procedures. The turret indicator light and the azimuth indicator are also used to assist in determining sectors of fire. Ammunition is designated for each TRP and reference point as prescribed by the platoon SOP or METT-T.

(2) **Target reference points/reference points.** Leaders designate natural or man-made terrain features as reference points. The gunner uses these reference points in target acquisition and range determination process during limited visibility. There will also be predesignated TRPs, which must be seen to be useful as TRPs or indirect fire targets. At least one TRP should always be in view using low magnification.

(a) The commander or platoon leader designates indirect fire targets used as TRPs so that target numbers can be assigned. If TRPs are within the sector of fire, the BC points them out and tells the gunner their designated reference numbers. TRPs should be heated so that the crew can acquire them with thermal sights.

(b) Normally, a gunner has at least one TRP but should not have more than four. The range card should show only pertinent data for reference points and TRPs.

(3) **Dead space.** Dead space is any area that cannot be observed or covered by direct fire systems within the sector of fire. All dead space within the sector of fire must be identified to allow the BC and platoon leader to plan the use of fires (for example, mortars, artillery) to cover that area. The crew, working with their wingman vehicle crew, must walk the engagement area so that the gunners can detect dead spaces through the ISUs.

(4) **Maximum engagement line.** The depth of the sector is normally limited to the maximum effective engagement range of the vehicle's weapon systems; however, it can be less if there are objects that

prevent the gunner from engaging targets at maximum effective engagement range. To assist in determining the distance to each MEL, the gunner or BC should use a map to make sure the MELs are shown correctly on the range card. MEL identification assists in decreasing the ammunition used on an engagement.

(5) **Weapon reference point.** The WRP is an easily recognizable terrain feature on the map. The WRP is used to assist leaders in plotting the vehicle's position, and to assist replacement personnel in finding the vehicle's position.

b. Preparation Procedures. The gunner prepares two copies of the range card. If alternate and supplementary firing positions are assigned, two copies are required for these as well. A copy is kept with the vehicle, and the other is given to the section leader for his sketch.

(1) Draw the weapon symbol in the center of the small circle. Draw two lines from the position of the BFV extending left and right to show the limits of the sector (Figure 2-62).

(2) Determine the value of each circle by finding a terrain feature farthest from the position that is within the weapon system's capability. Determine the distance to the terrain feature. Round off the distance to the next even hundredth, if necessary. Determine the maximum number of circles that will divide evenly into the distance. The result is the value of each circle. Draw the terrain feature on the appropriate circle on the range card. Clearly mark the increment for each circle across the area where DATA SECTION is written. For example, in Figure 2-63, page 2-126, a hilltop at 3,145 meters is used. The distance is rounded to 3,200 meters, divided by 8, and equals 400. Thus, each circle has a value of 400 meters.

(a) Figure 2-64, page 2-127, shows a farmhouse at 2,000 meters on the left limit. The right limit is noted by the wood line at 2,600 meters. Determine the distance to these features by the using a map or a hand-held laser range finder. The platoon forward observer will have a hand-held laser range finder. Note how the circle markings can assist in positioning the features on the range card.

(b) Draw all TRPs and reference points in the sector. Mark each of these with a circled number beginning with 1. Figure 2-65, page 2-128, shows the hilltop as RP 1 and a road junction as RP 2 and road junction RP 3. There are times when a TRP and a reference point are the same point (for example, RP 2 and RP 3 above). The TRP is marked with the first designated number in the upper right quadrant, and the reference point marked in the lower left quadrant of the cross. This occurs when a TRP is used for target acquisition and range determination. Road junctions are drawn by first determining the range to the junction, by drawing the junction, then finished by drawing the connecting roads from the road junction.

STANDARD RANGE CARD					
For use of this form see FM 7-8. The proponent agency is TRADOC.					
SQD _____	May be used for all types of direct fire weapons.				MAGNETIC NORTH
PLT _____					
CO _____					
DATA SECTION					
POSITION IDENTIFICATION				DATE	
WEAPON			EACH CIRCLE EQUALS _____ METERS		
NO.	DIRECTION / DEFLECTION	ELEVATION	RANGE	AMMO	DESCRIPTION
REMARKS:					

DA FORM 5517-R, FEB 86

Figure 2-62. Placement of weapon symbol and left and right limits.

STANDARD RANGE CARD					
For use of this form see FM 7-8. The proponent agency is TRADOC.					
SOD _____	May be used for all types of direct fire weapons.				MAGNETIC NORTH
PLT _____					
CO _____					
POSITION IDENTIFICATION			DATE		
WEAPON			EACH CIRCLE EQUALS <u>400</u> METERS		
NO.	DIRECTION / DEFLECTION	ELEVATION	RANGE	AMMO	DESCRIPTION
REMARKS:					

DA FORM 5517-R, FEB 86

Figure 2-63. Circle value.

STANDARD RANGE CARD					
For use of this form see FM 7-8. The proponent agency is TRADOC.					
SOD _____	May be used for all types of direct fire weapons.				MAGNETIC NORTH
PLT _____					
CO _____					
DATA SECTION					
POSITION IDENTIFICATION				DATE	
WEAPON			EACH CIRCLE EQUALS <u>400</u> METERS		
NO.	DIRECTION/ DEFLECTION	ELEVATION	RANGE	AMMO	DESCRIPTION
REMARKS:					
DA FORM 5517-R, FEB 86					

Figure 2-64. Terrain features for left and right limits.

STANDARD RANGE CARD
For use of this form see FM 7-8. The proponent agency is TRADOC.

SQD _____
PLT _____
CO _____

May be used for all types of direct fire weapons.

MAGNETIC NORTH

DATA SECTION

POSITION IDENTIFICATION			DATE		
WEAPON			EACH CIRCLE EQUALS <u>400</u> METERS		
NO.	DIRECTION DEFLECTION	ELEVATION	RANGE	AMMO	DESCRIPTION

REMARKS:

DA FORM 5517-R, FEB 86

Figure 2-65. Target reference points/reference points.

(c) Dead space is shown as an irregular circle with diagonal lines drawn inside (Figure 2-66). Any object that prohibits observation or coverage with direct fire will have the circle and diagonal lines extend out to the farthest maximum engagement line. If the area beyond the dead space is engageable, then the circle is closed. For example, an area of lower elevation will have a closed circle, because the area beyond it is engageable.

STANDARD RANGE CARD
 For use of this form see FM 7-8. The proponent agency is TRADOC.

SQD _____
 PLT _____
 CO _____

May be used for all types of direct fire weapons.

MAGNETIC NORTH

DATA SECTION

POSITION IDENTIFICATION			DATE		
WEAPON			EACH CIRCLE EQUALS <u>400</u> METERS		
NO.	DIRECTION DEFLECTION	ELEVATION	RANGE	AMMO	DESCRIPTION
REMARKS					

DA FORM 5517-R, FEB 86

Figure 2-66. Dead space.

(d) Maximum engagement lines are shown as in Figure 2-67, page 2-130. MELs are drawn at the maximum effective engagement range per weapon if there is no dead space to limit their range capabilities. Note how the MEL for HE extends beyond the dead space in Figure 2-66. This indicates a higher elevation where HE area suppression is possible.

MELs are not drawn through dead space. The maximum effective ranges for Bradley weapon systems are—

COAX..... 900 meters (tracer burnout) HEI-T/TOW (Basic)3,000 meters (impact)
 APDS-T 1,700 meters (tracer burnout) TOW 23,750 meters (impact)

STANDARD RANGE CARD

For use of this form see FM 7-8. The proponent agency is TRADOC.

SOD _____
 PLT _____
 CO _____

May be used for all types of direct fire weapons

MAGNETIC NORTH

DATA SECTION

POSITION IDENTIFICATION			DATE		
WEAPON			EACH CIRCLE EQUALS <u>400</u> METERS		
NO	DIRECTION DEFLECTION	ELEVATION	RANGE	AMMO	DESCRIPTION
REMARKS:					

DA FORM 5517-R. FEB 86

Figure 2-67. Maximum engagement lines.

(e) The WRP shown in Figure 2-67 is represented as a line with a series of arrows extending from a known terrain feature and pointing in the direction of the Bradley symbol. This feature is numbered last. The WRP location is given a six-digit grid. When there is no terrain feature to be designated as the WRP, the vehicle's location is shown as an eight-digit grid coordinate in the remarks block of the range card. (In Figure 2-68, page 2-132, the WRP is number 4.)

NOTE: When the WRP cannot be drawn precisely on the sketch, due to the vehicle location, it is drawn to the left or right nearest the actual direction.

(3) Complete the data section. (Figure 2-69, page 2-133.)

(a) *Position identification.* List either primary, alternate, or supplementary. Alternate and supplemental positions must be clearly identified.

(b) *Date.* Show date and time the range card was completed. Range cards are like fighting positions, constantly being updated. The date and time are vital in determining the current data.

(c) *Weapon.* The weapon block indicates M2 and the vehicle bumper number.

(d) *Each circle equals _____ meters.* Write in the distance, in meters, between circles.

(e) *NO (number).* Starting with L and R limits, then list TRPs and RPs in numerical order.

NOTE: The platoon leader may designate a vehicle to be dedicated for AP, HEI-T, or TOW targets. This is dictated by platoon SOP or as needed by METT-T.

(f) *Direction/deflection.* The direction is in degrees and taken from a lensatic compass. The most accurate technique is to have the gunner aim at the terrain feature, and to have the driver dismount and align himself with the gun barrel and the terrain feature to measure the azimuth. To achieve correct deflection and elevation readings of the terrain feature, select TOW. Show the deflection reading taken from the BFV's azimuth indicator in the deflection block next to the magnetic azimuth.

(g) *Elevation.* Show the gun elevation reading in tensor hundreds of mils. The smallest increment of measure on the elevation scale is tens of mils. Any number other than "0" is preceded by a "plus" or "minus" symbol to show whether the gun needs to be elevated or depressed. Ammunition and range must be indexed to have an accurate elevation reading.

STANDARD RANGE CARD					
For use of this form see FM 7-8. The proponent agency is TRADOC.					
SQD _____	May be used for all types of direct fire weapons				MAGNETIC NORTH
PLT _____					
CO _____					
POSITION IDENTIFICATION			DATE		
WEAPON			EACH CIRCLE EQUALS METERS <u>400</u>		
NO	DIRECTION DEFLECTION	ELEVATION	RANGE	AMMO	DESCRIPTION
REMARKS					

Figure 2-68. Weapon reference point.

(h) *Range*. Distance, in meters, from vehicle position to L and R limits and TRPs and RPs.

(i) *Ammo*. List types of ammunition used.

STANDARD RANGE CARD
For use of this form see FM 7-8. The proponent agency is TRADOC.

SQD A22
PLT Z
CO C

May be used for all types of direct fire weapons

MAGNETIC NORTH

POSITION IDENTIFICATION			DATE		
PRIMARY			3 MAR / 1140 HRS		
WEAPON			EACH CIRCLE EQUALS		
MZ C-21			400		
NO.	DIRECTION DEFLECTION	ELEVATION	RANGE	AMMO	DESCRIPTION
L	350°/5800 ft	∅ ft	2000 M	TOW2	FARMHOUSE
R	105°/920 ft	+ 10 ft	2600 M	TOW2	R/SIDE WOODLINE
1	6400 ft	+ 30 ft	3200 M	TOW2	RP - HILLTOP
2	5910 ft	+ 10 ft	2700 M	TOW2	TRP - AB002 RJ
3	60 ft	- 10 ft	1800 M	TOW2	TRP - AB002 RJ
REMARKS					
4 WRP - RJ AT 13629411, 100° AT 320 M					

DA FORM 5517-R, FEB 86

Figure 2-69. Example of a completed range card.

(j) *Description.* List the name of the object; for example, farmhouse, wood line, hilltop.

(k) *Remarks.* Enter the WRP data. As a minimum, WRP data include a description of what the WRP is, a six-digit or eight-digit grid coordinate

of the WRP, the magnetic azimuth and the distance from the WRP to the vehicle position.

(4) Complete the marginal information at the top of the card (Figure 2-69, page 2-133).

(a) *Unit description - bumper number, plt, co.* Never indicate a unit higher than company.

(b) *Magnetic north.* Orient the range card with the terrain and draw the direction of the magnetic north arrow.

c. **Firing Position.** After a range card has been completed, the position should be marked with ground stakes. This enables the Bradley or a replacement Bradley to reoccupy the position and be able to use the range card data.

(1) **Stake the position.**

Before the Bradley is moved, the position should be staked. Three stakes are required to effectively mark the position as shown in Figure 2-70.

(a) One stake is placed in front of the Bradley. It is centered on the driver's station and just touching the hull. The stake should be long enough for the driver to see it when in position. The other two stakes are placed parallel to the left track and lined up with the hub on the front and rear wheels. The stakes should be placed close to the Bradley with only enough clearance to move the Bradley into position.

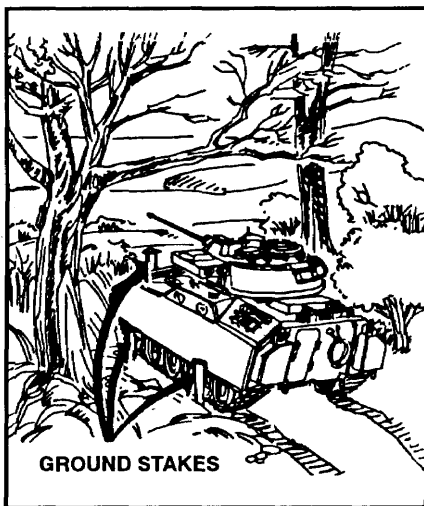

Figure 2-70. Stake the position.

(b) The stakes should be driven firmly into the ground. Engineer tape or luminous tape can be placed on the friendly side of the stakes so that the driver can see them. A rock is placed at each of the front two corners of the vehicle to assist in reoccupation if the stakes are lost.

(2) Move into the position. If the situation permits, a ground guide can be used to assist the driver.

(a) If a ground guide cannot be used because of enemy fire, the driver moves the Bradley in, parallel to the side stakes, with the front stake centered on the driver's station.

(b) Once the Bradley is in position, the gunner should index the range and azimuth for one of the TRPs on the range card. If the sight is aligned on the TRP, the Bradley is correctly positioned. If the sight is not aligned on the TRP, the gunner should tell the driver which way to move the vehicle to align the sight on the target. Only minor adjustments should be necessary.

(c) If the stakes are lost and the position is not otherwise marked, the vehicle is moved to the approximate location. The BC or gunner can use a compass to find the left and right limits. The vehicle should be moved until it is within 6 to 8 inches of exact position, if time allows.

2-21. TYPES OF POSITIONS

Defensive positions may be classified as primary, alternate, or supplementary. All positions should provide observation and fields of fire for the weapon systems within the platoon's assigned sector. Defensive positions should take advantage of natural cover and concealment even before soldiers begin to camouflage them. The platoon improves its ability to reposition by using covered and concealed routes, by using communications trenches, and by rehearsing the repositioning by fire and movement.

a. **Primary.** A primary position provides a soldier, weapon system, or platoon/squad the best position from which it can accomplish the assigned mission.

b. **Alternate.** Alternate positions allow soldiers, weapon systems, squads, or platoons to cover the same sector of fire covered from the primary position. Alternate positions are occupied when the primary position becomes untenable and when engaging enemy forces in order to prevent detection.

c. **Supplementary.** Supplementary positions provide the best means to accomplish a task that cannot be accomplished from the primary or alternate positions. Platoon leaders normally locate supplementary positions to cover additional enemy avenues of approach and to protect the flanks and rear of the platoon position.

2-22. BFV POSITIONS

For a detailed description of BFV positioning, see paragraph 2-19 and paragraph 2-28.

2-23. SQUAD POSITIONS

As a guideline, a squad can physically occupy a front of about 100 meters. From this position, it can defend 200 to 250 meters of frontage. The frontage distance between two-man fighting positions should be

about 20 meters (allowing for a lazy W configuration on the ground; this would put fighting positions about 25 meters apart physically). Every position should be observed and supported by the fires of at least two other positions. One-man fighting positions may be located closer together to occupy the same platoon frontage. The distance between fighting positions depends on the leader's analysis of the factors of METT-T. In determining the best distance between fighting positions, the squad leader must consider—

- The requirement to cover the squad's assigned sector by fire.
- The need for security; that is, prevent infiltrations of the squad and platoon positions.
- The requirement to prevent the enemy from using hand grenades effectively to assault adjacent positions, should he gain a fighting position.

2-24. PLATOON POSITIONS

The platoon leader assigns each section and squad a primary position and sector of fire. He should also assign supplementary positions. BCs and squad leaders normally select alternate positions for their BFVs and squads. The platoon leader designates responsibility for manning OPs and gives a general location for each OP. Each squad and vehicle section must cover its own sector of fire and overlap into those of the other squad or section. Flank sectors should overlap those of adjacent platoons.

2-25. SECTOR SKETCHES

Gunners prepare the range cards. Squad leaders prepare squad sector sketches. Section leaders prepare section sketches, and the platoon leader prepares the platoon sketch.

a. The platoon leader or platoon sergeant can use acetate on a map or a hand drawn sketch to draw the platoon sketch. Accurate and detailed sketches aid in fire planning, distribution of fire, and control of the platoon fires.

b. The squad leaders and section leaders make two copies of their sector sketches; one copy goes to the platoon leader, the other remains at the position. The squad leaders and section leaders draw sector sketches as close to scale as possible, showing (Figure 2-71)—

- Main terrain features in the sector and the range to each.
- Each primary position.
- Engagement areas or primary and secondary sectors of fire covering each position.
- M249 machine gun FPLs or PDFs.

- Type of weapon in each position.
- TRPs/reference points in the sector.
- OP locations.
- Dead space.
- Obstacles.
- MELs for all BFV weapon systems.
- MELs for Dragons and AT4s.
- Indirect fire targets.

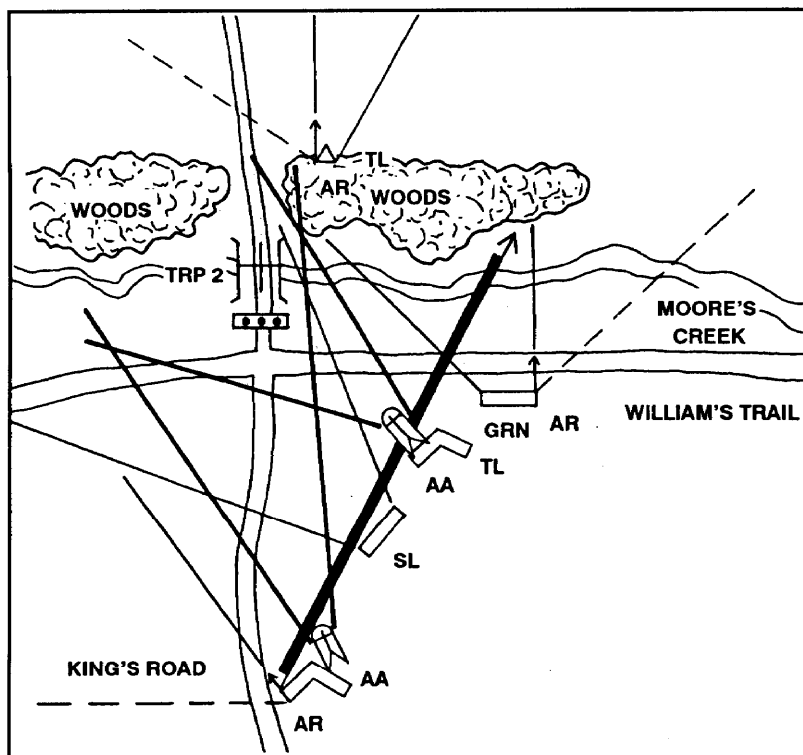

Figure 2-71. Squad sector sketch.

c. Squad leaders and section leaders prepare their sketches and submit them to the platoon leader. Gunners submit their range cards to the mounted section leader. The platoon leader combines all the sketches and range cards to prepare a platoon sector sketch.

d. A platoon sector sketch is drawn as close to scale as possible and includes a target list for direct and indirect fires. One copy is given to the company commander, one to the mounted leader, and the third copy to the dismount leader. As a minimum, the sketch shows (Figure 2-72)—

- Primary and secondary sectors or engagement areas.
- Primary, alternate, and supplementary Bradley vehicles and squad positions.
- Remount points.
- Dragon and M249 machine gun positions with primary sectors of fire.
- M249 FPLs or PDFs.
- MELs for TOW, 25-mm, coax weapons.
- OPs.
- TRPs and reference points.
- Mines and other obstacles.
- Indirect target locations and FPF location (if applicable.)
- Position and sector of flanking unit vehicles.
- Priority of engagement by bumper number.

e. Platoon leaders coordinate with adjacent platoons. Squad leaders coordinate with adjacent squads so that all positions and all platoon and squads are mutually supporting. The platoon leader checks to ensure this coordination has taken place. Coordination normally is initiated from left to right. Gaps between positions are covered by fire as a minimum and contact points are established to ensure friendly forces meet at some specific point on the ground to tie in their flanks. The information exchanged includes—

- Locations of primary, alternate, and supplementary positions; and sectors of fire for BFVs, machine guns, and Dragons.
- Location of dead space between platoons and how it is to be covered.
- Location of OPs.
- Location and types of obstacles and how to cover them.
- Patrols to include size, type, time of departure and return, and routes.

In many cases, a sector sketch can be exchanged that accomplishes most of this. In some cases, BFVs may be positioned to support the dismount element and flank platoons. This may be a compromise position that must be occupied to tie in a vulnerable flank. Since platoons defend as part of a company team, platoon leaders must be especially careful of tying in their flanks.

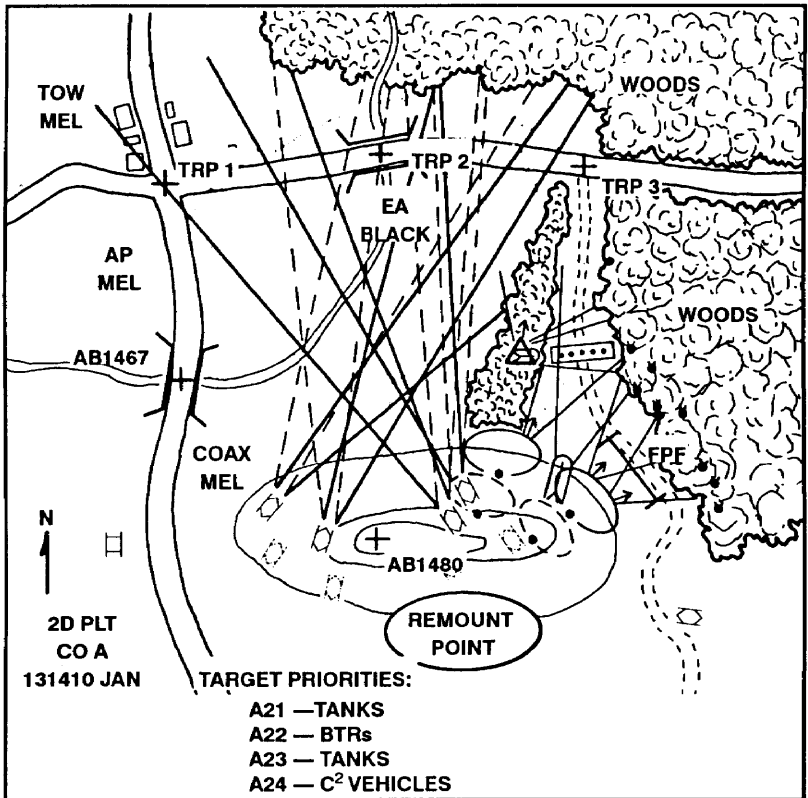

Figure 2-72. Platoon sector sketch.

f. Because platoons dismount their infantry in the defense, the remount must be planned in detail. This is especially true where subsequent movement is an integral part of the defensive plan or when the dismount and vehicle elements are separated. The inability to plan and execute a speedy remount causes the advantage of the BFVs' speed to be negated as the vehicles are forced to wait for the dismounted infantry to link up and remount. Planning for the remount at platoon level should include—

- Remount rehearsal.
- Remount location.
- Reconnaissance of route to the remount point by both the vehicle and dismount elements during good and limited visibility.
- Marking the route to the remount point.

- Signals to initiate the remount and contingencies for limited visibility, loss of communications, and loss of leaders.

2-26. FIRE CONTROL MEASURES

Bradley commanders and squad leaders should use the fire control principles and basic fire control and distribution measures discussed in Section I to assist with the proper concentration and distribution of fires in the defense. To prevent fratricide and conserve the platoon's combat power when possible, forces must avoid engagements close to friendly infantry or vehicles.

2-27. COORDINATION

Coordination between adjacent platoons, squads, or sections is normally from left to right and from front to rear. Information exchanged includes the following:

- Location(s) of leaders.
- Location of primary, alternate, and supplementary positions and sectors of fire of machine guns, antiarmor weapons, squads, and sections.
- Route to alternate and supplementary positions.
- Location of dead space between squads and platoons and how to rover it.
- Location of OPs and withdrawal routes back to the platoon's, squad's, or sections's position.
- Location and types of obstacles and how to cover them.
- Patrols to be conducted to include their size, type, times of departure and return, and routes.
- Location, activities, and passage plan for reconnaissance platoon and other friendly forces forward of the platoon's position.
- Signals for fire and cease fire and any other signals that may be observed.
- Engagement and disengagement criteria.

2-28. FIGHTING POSITIONS

This paragraph discusses techniques for the construction of infantry and vehicle fighting positions. Infantrymen use hasty; one-, two-, and three-soldier; machine gun; medium and light antitank positions. BFVs use hull- and turret-defilade positions. Soldiers must construct fighting and vehicle positions that protect them and allow them to fire into their assigned sectors. Tables 2-4 and 2-5 provide characteristics of individual and crew-served fighting positions, respectively. Table 2-6 (page 2-157) provides dimensions of vehicle positions. (For more information, see FM 5-103.)

FM 7-7J

Type of Position	Estimated Construction Time (man-hours)	Equipment Requirements	Direct Small Caliber Fire	Indirect Fire Blast and Fragmentation (Near-Miss)*	Indirect Fire Blast and Fragmentation (Direct Hit)	Nuclear Weapons**	Remarks									
HASTY																
Crater	0.2	Hand tools	7.62-mm	Better than in open—no overhead protection	None	Fair										
Skirmisher's trench	0.5	Hand tools	7.62-mm	Better than in open—no overhead protection	None	Fair										
Prone position	1.0	Hand tools	7.62-mm	Better than in open—no overhead protection	None	Fair	Provides all-round cover									
DELIBRATE																
One-soldier position	3.0	Hand tools	12.7-mm	Medium artillery no closer than 30 ft—no overhead protection	None	Fair										
One-soldier position with 1 1/2 ft overhead cover	8.0	Hand tools	12.7-mm	Medium artillery no closer than 30 ft	None	Good	Additional cover provides protection from direct hit small mortar blast									
Two-soldier position	6.0	Hand tools	12.7-mm	Medium artillery no closer than 30 ft—no overhead protection	None	Fair										
Two-soldier position with 1 1/2 ft overhead cover	11.0	Hand tools	12.7-mm	Medium artillery no closer than 30 ft	None	Good	Additional cover provides protection from direct hit small mortar blast									
LAW position	3.0	Hand tools	12.7-mm	Medium artillery no closer than 30 ft—no overhead protection	None	Fair										
NOTE: Chemical protection is assumed because of individual protective masks and clothing.																
<p>* Shell sizes are:</p> <table style="margin-left: 40px;"> <tr> <td></td> <td>Light</td> <td>Medium</td> </tr> <tr> <td>Mortar</td> <td>82-mm</td> <td>120-mm</td> </tr> <tr> <td>Artillery</td> <td>122-mm</td> <td>152-mm</td> </tr> </table>									Light	Medium	Mortar	82-mm	120-mm	Artillery	122-mm	152-mm
	Light	Medium														
Mortar	82-mm	120-mm														
Artillery	122-mm	152-mm														
** Nuclear protection ratings are rated poor, fair, good, very good, and excellent.																

Table 2-4. Characteristics of individual fighting positions.

Type of Position	Estimated Construction Time (man-hours)	Equipment Requirements	Direct Small Caliber Fire	Indirect Fire Blast and Fragmentation (Near-Miss)*	Indirect Fire Blast and Fragmentation (Direct Hit)	Nuclear Weapons**	Remarks
Dragon position	4.0	Hand tools	12.7-mm	Medium artillery no closer than 30 ft—no overhead protection	None	Fair	
Dismounted TOW position	11.0	Hand tools	12.7-mm	Medium artillery no closer than 30 ft—no overhead protection	None	Fair	
90-mm RCLR position	6.0	Hand tools	12.7-mm	Medium artillery no closer than 30 ft—no overhead protection	None	Fair	
Machine gun position	7.0	Hand tools	12.7-mm	Medium artillery no closer than 30 ft—no overhead protection	None	Fair	
Machine gun position with 1 1/2 ft overhead cover	12.0	Hand tools	12.7-mm	Medium artillery no closer than 30 ft	None	Good	
Mortar position	14.0	Hand tools	12.7-mm	Medium artillery no closer than 30 ft—no overhead protection	None	Fair	

NOTE: Chemical protection is assumed because of individual protective masks and clothing.

* Shell sizes are:

	Light	Medium
Mortar	82-mm	120-mm
Artillery	122-mm	152-mm

** Nuclear protection ratings are rated poor, fair, good, very good, and excellent.

Table 2-5. Characteristics of crew-served fighting positions.

a. **Protection.** Fighting positions protect soldiers by providing *cover* through sturdy construction, and by providing *concealment* through positioning and proper camouflage. The enemy must not be able to identify the position until it is too late and he has been effectively engaged. When possible, soldiers should site positions in nonobvious places, behind natural cover, and in an easy to camouflage location. The most important step in preparing a fighting position is to make sure that it cannot be seen. In constructing fighting positions, soldiers should always—

- Dig the positions armpit deep.
- Fill sandbags about 75 percent full.
- Revet excavations in sandy soil.
- Check stabilization of wall bases.
- Inspect and test the position daily, after heavy rain, and after receiving direct or indirect fires.
- Maintain, repair, and improve positions as required.
- Use proper materiel. Use it correctly.

NOTE: In sandy soil, vehicles should not be driven within 6 feet of the positions.

b. **Siting to Engage the Enemy.** Soldiers must be able to engage the enemy within their assigned sectors of fire. They should be able to fire out to the maximum effective range of their weapons with maximum grazing fire and minimal dead space. M203 fires are planned where dead space is found. Soldiers and leaders must be able to identify the best location for their positions that meet this criteria. Leaders must also ensure that fighting positions provide interlocking fires. This allows them to cover the platoon's sector from multiple positions and to provide a basis for final protective fires.

c. **Preparation by Stages.** Leaders must ensure that their soldiers understand when and how to prepare fighting positions based on the situation. Soldiers normally prepare hasty fighting positions every time the platoon halts (except for short security halts), and only half of the platoon digs in while the other half maintains security. Soldiers prepare positions in stages and require a leader to inspect the position before moving on to the next stage. See the following example.

EXAMPLE

STAGE 1. The platoon leader checks the fields of fire from the prone position and has the soldier emplace sector stakes (Figure 2-73).

- Sector stakes emplaced (primary sector).
- Grazing fire log or sandbag positioned between the sector stakes.

- The aiming stake(s), if required, is emplaced to allow limited visibility engagement of a specific target.
- Elbow holes are scooped out.
- The outline of the position is traced on the ground.
- Fields of fire are cleared for both primary and secondary sectors.
- The leader inspects the position.

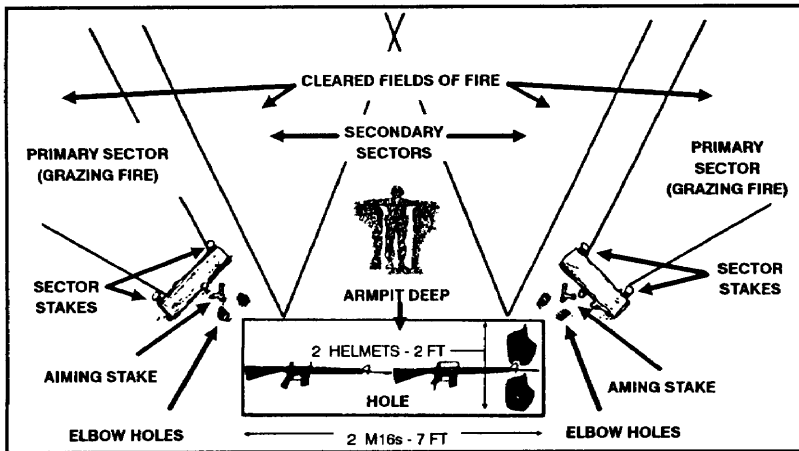

Figure 2-73. Stage 1, preparations of a fighting position.

STAGE 2. The retaining walls for the parapets are prepared at this stage. These ensure that there is at least a one-helmet distance from the edge of the hole to the beginning of the front, flank, and rear cover (Figure 2-74).

- The front wall is two to three sandbags (or logs) high. For a two-soldier position, it is about two M16 rifles long.
- The flank walls are the same height, but only one M16 rifle long.
- The rear wall is one sandbag high and one M16 long.
- If logs are used, they must be held firmly in place with strong stakes.
- The leader inspects the position.

STAGE 3. During stage 3, the position is dug and the dirt is thrown forward of the parapet retaining walls and then packed down hard (Figure 2-75).

- The position is dug armpit deep.
- The parapets are filled in order of front, flanks, and rear.

- The parapets and the entire position are camouflaged.
- Grenade sumps are dug and the floor sloped toward them.
- Storage areas for the two rucksacks may also be dug into the rear wall.
- The leader inspects the position.

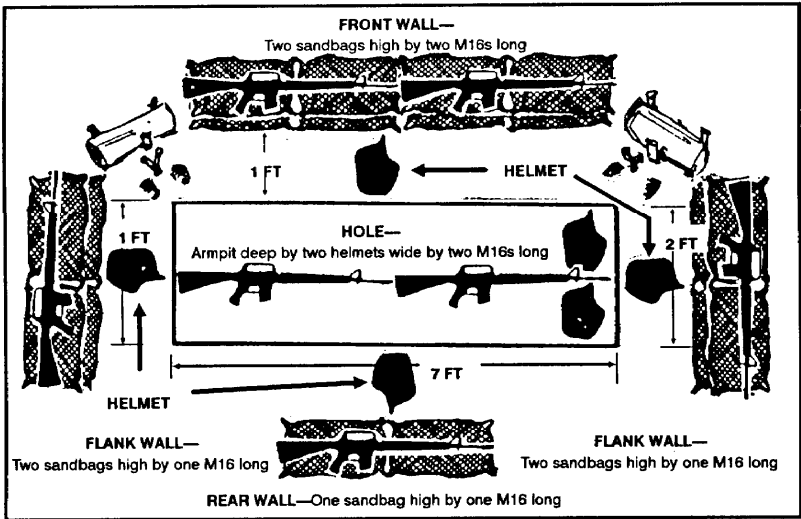

Figure 2-74. Stage 2, preparations of a fighting position.

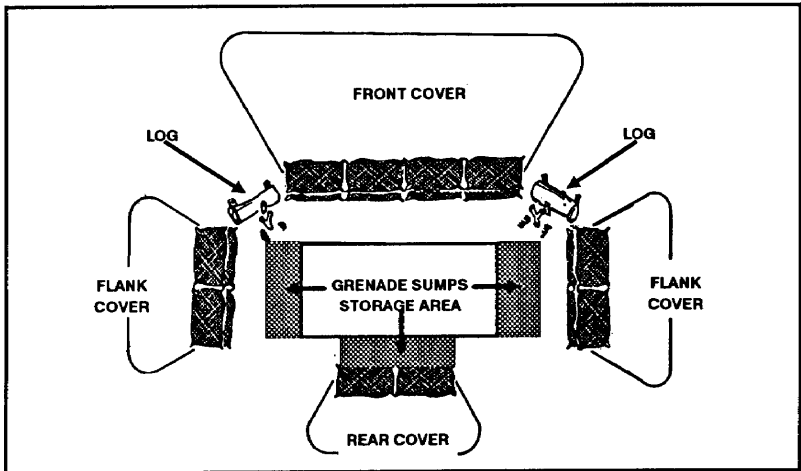

Figure 2-75. Stage 3, preparations of a fighting position.

STAGE 4. The overhead cover is prepared (Figure 2-76).

- Five to six logs 4 to 6 inches in diameter and two M16s long are placed over the center of the position.
- Waterproofing (plastic bags, ponchos) are placed on top of these logs.
- Then 6 to 8 inches of dirt or sandbags are put on top of the logs.
- The overhead cover and the bottom of the position are camouflaged.

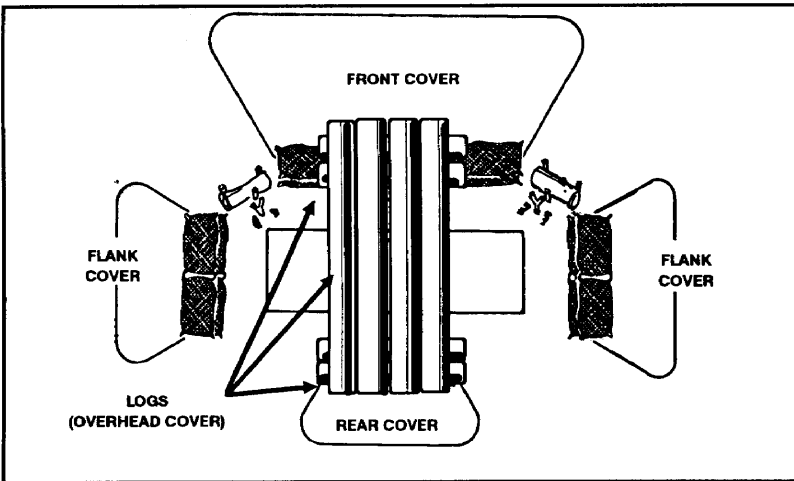

Figure 2-76. Stage 4, preparations of a fighting position.

d. **Types of Fighting Positions.** Because there are many different types of fighting positions, the number of personnel, types of weapons, the time available, and the terrain dictate the type of position.

(1) **Hasty fighting position.** Soldiers prepare this type of position when there is little or no time to prepare fighting positions (Figure 2-77). They locate it behind whatever cover is available. The position should give frontal protection from direct fire while allowing fire to the front and oblique. A hasty position may consist simply of a rucksack placed beside a tree or large rock. For protection from indirect fire, a hasty fighting position should be in a small depression or hole at least 18 inches deep. The term hasty position does not mean there is no digging. Even if there are only a few minutes, a prone shelter can be scraped out or dug to provide some protection. This type of position is well-suited for ambushes or for protection of overmatching element during raids and attacks. Hasty positions can also be the first step in construction of more elaborate positions.



Figure 2-77. Hasty fighting position.

(2) **One-soldier fighting position.** This type of position allows choices in the use of cover; the hole only needs to be large enough for one soldier and his gear. It does not have the security of a two-soldier position. The one-soldier fighting position must allow a soldier to fire to the front or to the oblique from behind frontal cover. (Figure 2-78.)



Figure 2-78. One-soldier fighting position.

(3) **Two-soldier fighting position.** A two-soldier fighting position can be prepared in close terrain. It can be used where grazing fire and mutual support extend no farther than to an adjacent position. It can be used to cover dead space just in front of the position. One or both ends of the hole are extended around the sides of the frontal cover. Changing a hole this way lets both soldiers see better and have greater sectors of fire to the front. Also, during rest or eating periods, one soldier can watch the entire sector while the other sleeps or eats. If they receive fire from their front, they can move back to gain the protection of the frontal cover. By moving about 1 meter, the soldiers can continue to find and hit targets to the front during lulls in enemy fire. This type of position requires more digging and is harder to camouflage. It is also a better target for enemy hand grenades (Figure 2-79.)

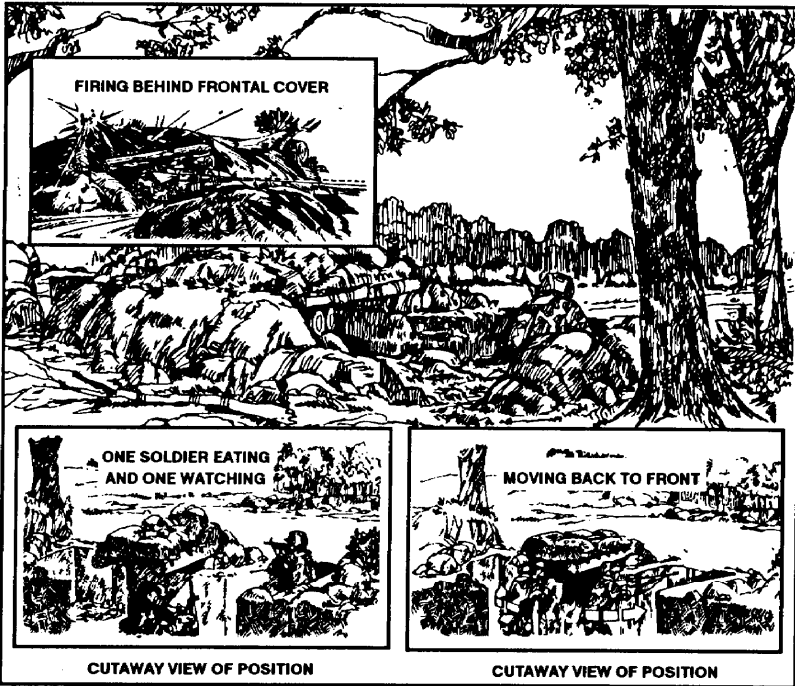

Figure 2-79. Two-soldier fighting position.

(4) **Three-soldier fighting position.** A three-soldier position has several advantages over the other types of positions. There is a leader in each position, which makes command and control easier. It supports

continuous, secure operations better than other positions. One soldier can provide security; one can do priority work; and one can rest, eat, or perform maintenance. This allows the priority of work to be completed more quickly than in a one-soldier or two-soldier position. This position allows the platoon to maintain combat power and security without either shifting personnel or leaving positions unmanned. It provides 360-degree observation and fire, and it is more difficult for the enemy to destroy, because he must kill or suppress three soldiers.

(a) When using three-soldier positions, the leader must consider the several things. Either the distance between positions must be increased or the size of the squad's sector reduced. The choice depends mainly on visibility and fields of fire. Because the squad leader is in a fighting position that will most likely be engaged during the battle, he cannot exert personal control over the other two positions. The squad leader keeps control over the battle by—

- Clearly communicating plans and intent to his squad to include control measures and fire plans.
- Using prearranged signals like flares, whistles, or tracers.
- Positioning key weapons in his fighting position.
- Placing his fighting position so that it covers key or decisive terrain.
- Placing his fighting position where his team might be able to act as a reserve.

(b) The three-soldier emplacement is the T-position. This basic design can be changed by adding or deleting berms, changing the orientation of the T, or shifting the position of the third soldier to form an L instead of a T. (Figure 2-80, page 2-150.) The first layout of the position is oriented to fire on expected enemy avenues of approach from any direction(s). Berms are added based on METT-T factors. They cannot block observation or fire into assigned primary or alternate sectors. Berms should be designed to support overhead constructions. Logs of sufficient diameter (4 to 6 inches) or long pickets are used to support overhead cover for the position. They are placed a minimum of 1 foot back from the edge of the hole, or one fourth the depth of the hole, whichever is greater. The position is completed when natural camouflage materials are added to hide the position and strengthen it.

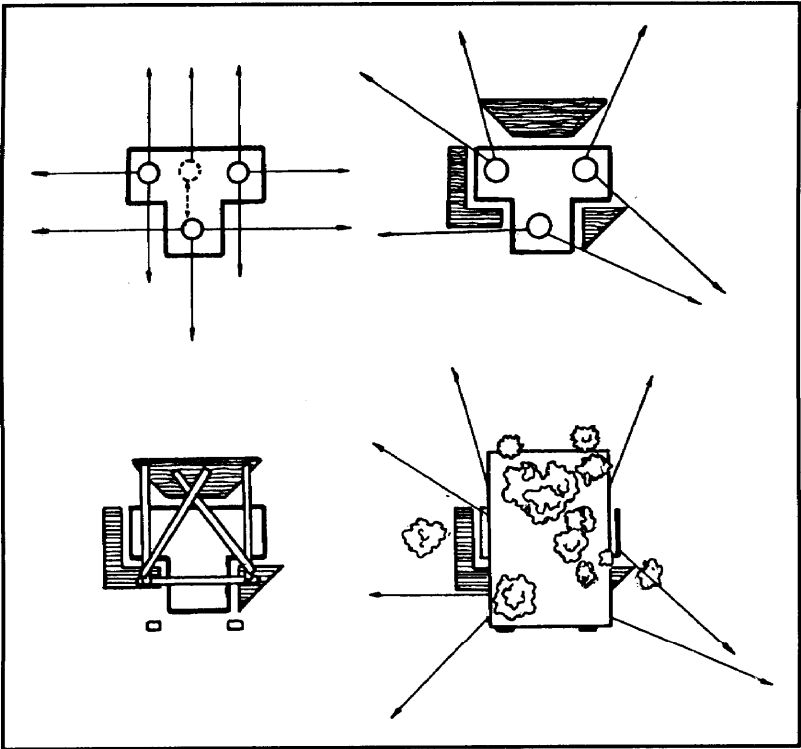

Figure 2-80. Three-soldier T-position.

(5) **Machine gun position.** The primary sector of fire is usually to the oblique so that the gun can fire across the platoon's front. The tripod is used on the side that covers the primary sector of fire. The biped legs are used on the side that covers the secondary sector of fire. When changing from primary to secondary sectors, the gunner moves only the machine gun. Occasionally, a sector of fire that allows firing directly to the front is assigned, but this can reduce the frontal cover for the crew when firing to the oblique. (Figure 2-81.)

(a) After the platoon leader positions the machine gun, he marks the position of the tripod legs and the limits of the sectors of fire. The crew then traces the outline of the hole and the frontal cover (if it must be improved).

(b) The crew digs the firing platforms first to lessen their exposure in case they have to fire before they complete the position. The platforms

must not be so low that the gun cannot be traversed across its entire sector of fire. This reduces the profile of the gunner when he is firing and reduces the height of the frontal cover.

(c) After digging the firing platforms, the crew digs the hole. They first place the dirt where frontal cover is needed. They dig the hole deep enough to protect them and still let the gunner fire the gun with comfort, usually about armpit deep. When the frontal cover is high and thick enough, the crew uses the rest of the dirt to build flank and rear cover. Trench-shaped grenade sumps are dug at various points so that either soldier can kick a grenade into one if needed. Overhead cover for a machine gun position is built the same as for a two-soldier position.

NOTE: In some positions, a machine gun might not have a secondary sector of fire; so, only half of the position is dug.

(d) When there is a three-soldier crew for a machine gun, the ammunition bearer digs a one-soldier fighting position to the flank. The ammunition bearer's position is connected to the gun position by a crawl trench. From his position, the ammunition bearer can see and fire to the front and to the oblique. Usually, the ammunition bearer is on the same side as the FPL or PDF. This allows him to see and fire his rifle into the machine gun's secondary sector, and to see the gunner and assistant gunner.

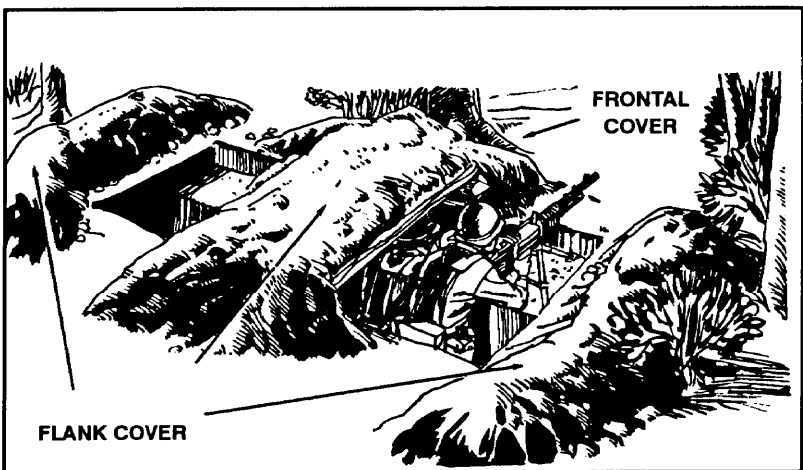

Figure 2-81. Machine gun position.

(6) **Dragon position.** The Dragon can be employed from hasty or completed positions. However, some changes are required. (Figure 2-82.)

DANGER

DRAGON BACKBLAST AND MUZZLE BLAST MUST BE CONSIDERED TO AVOID INJURING PERSONNEL. WHEN A DRAGON IS FIRED FROM A COMPLETED POSITION, THE MUZZLE END OF THE LAUNCHER MUST EXTEND 6 INCHES BEYOND THE FRONT OF THE HOLE. THE REAR OF THE LAUNCHER MUST EXTEND OUT OVER THE REAR OF THE HOLE.

(a) As the missile leaves the launcher, the stabilizing fins unfold. During firing, the gunner must keep the weapon at least 6 inches above the ground to allow room for the fins to unfold. The hole is only waist deep to allow the gunner to move while tracking a target. Because of the height of the Dragon gunner above ground level, the frontal cover should be high enough to hide his head and, if possible, the backblast of the Dragon. A hole is dug in front of the position for the biped legs.

(b) When the Dragon can be fired only in one direction, the position is adjusted to have cover and concealment from all other directions and should be fired to the oblique. This protects the position from frontal fire and allows engagement of the target from the flank. Both ends of the launcher must extend out over the edges of the hole.

(c) Overhead cover must be built on the flanks. Cover must be large enough for the gunner, the tracker, and the missiles. Overhead cover that allows fire from underneath it can be built if the backblast area is clear. However, overhead cover must be well camouflaged.

(d) Selection and preparation of alternate positions for a Dragon have a high priority since the Dragon is an important weapon and is easy to detect. When preparing an alternate position, the gunner should select and improve a covered route to it so he can move to the position under fire.

(7) **Light antitank weapon, AT4, and Flash positions.** The LAW, the AT4, and the Flash can be fired from infantry fighting positions. If the LAW, AT4, or Flash is to be fired from a two-soldier position, the gunner must ensure that the other soldier is not in the backblast area. The front edge of a fighting position is a good elbow rest to help the gunner steady the weapon and to gain accuracy. The LAW or Flash gunner leans against

the front or side wall of the hole for greater stability when firing (Figure 2-83). When firing the AT4, the gunner leans against the rear wall—his elbows are not supported.



Figure 2-82. Dragon position.



Figure 2-83. Light antitank weapon position.

e. **Trenches.** When there is time and help, trenches should be dug to connect fighting positions so soldiers can move by covered routes. The depth of a trench depends on the type of help and equipment available. Without engineer help, platoons dig crawl trenches (about 3 feet deep by 2 feet wide); with engineer help standard trenches are dug. The trench should zigzag so the enemy cannot fire down a long section of it. Platoons normally dig crawl trenches because engineer assets are

usually limited. Platoons use crawl trenches to conceal their movement into and within positions to provide minimum protection. Trenches use a zigzagging or winding pattern. Spoil is placed on parapets, normally on each side of the trench. If the trench runs across a forward slope, all the spoil is placed on the enemy side to make the forward parapet higher. All spoil needs careful concealment from enemy direct observation. (Figure 2-84.)



Figure 2-84. Crawl trenches.

f. **Vehicle Positions.** Initially, vehicles use natural cover and concealment in hide positions to increase survivability. As time, assets, and situation permit, positions are prepared using organic excavation equipment or engineer support. Priority is given to those vehicles containing essential equipment or supplies. Crews should use these fighting positions for individual protection as well.

(1) Parapets positioned at the front of or around major weapons systems provide improved protection from direct fire and from blast and

fragments of indirect fire artillery, mortar, and rocket shells. At its base, the parapet should be at least 8 feet thick. The parapet functions as a standoff barrier for impact-detonating direct fire HEAT and ATGM projectiles. The parapet should cause the fuzes to activate, thereby increasing survivability for the protected vehicles. If the enemy uses kinetic energy, direct fire armor-piercing, or hypervelocity projectiles, it is impractical to construct parapets thick enough for protection. To protect against these projectiles, deep-cut, hull defilade, or turret defilade positions are prepared. The dimensions for fighting and protective positions for essential vehicles are constructed no larger than needed.

(2) Success on the battlefield requires maneuver among fighting positions between main gun firings. Maximum use of terrain is required to conceal fighting vehicles maneuvering among fighting positions. After a major weapon system fires its main gun, the vehicle should move concealed to another position before firing again. If the major weapon system immediately reappears in the old position, the enemy knows where to fire his next round. Table 2-6, page 2-156, summarizes the dimensions of the hasty and deliberate vehicle positions discussed in the following paragraphs.

(a) *Hasty positions.* Hasty fighting positions for combat vehicles including APCs, CEVs, and mortar carriers take advantage of natural terrain features. These positions are prepared with a minimum of construction effort. A frontal parapet, as high as practical without interfering with the vehicles' weapon systems, shields from frontal attack and provides limited concealment if properly camouflaged. Protection is improved if the position is made deeper and the parapet is extended around the vehicle's sides. Because of the false sense of security provided by parapets against kinetic energy and hypervelocity projectiles, hasty vehicle fighting positions with parapets are not recommended for tanks, BFVs, and ITVs. Hasty fighting positions do offer protection from HEAT projectiles and provide limited concealment if properly camouflaged. As the tactical situation permits, hasty positions are improved to deliberate positions.

(b) *Deliberate positions.* Deliberate fighting positions are required to protect a vehicle from kinetic energy and hypervelocity projectiles. The position is constructed in four parts: hull defilade, concealed access ramp or route, hide location, and turret defilade. (Figures 2-85, page 2-158; 2-86 and 2-87, page 2-159.)

(3) Positions formed by natural terrain are best because of easy modification. If preparation is necessary, extensive engineer support is required. Each position is camouflaged with either natural vegetation or a camouflage net, and the spoil is flattened out or hauled away. All fighting positions for fighting vehicles (tanks, BFVs, ITVs) are planned

as deliberate positions. Since the lack of time usually does not allow the full construction of a deliberate position, only some parts of the position are prepared. For example, the complete fighting position for a BFV requires the construction of a hull defilade, turret defilade, concealed access ramp or route, and hide location all within the same fighting position. The maneuver team commander uses organic and engineer earthmoving assets and usually only constructs parts of the fighting position.

(4) Digging hide locations and concealed routes between fighting positions is normally not practical due to the lack of engineer assets and time. Engineer assets are used to dig the hull and turret defilade positions only. The ramps and concealed routes should require only partial clearing and leveling with blade tanks or engineer equipment because natural concealed routes and hide locations are used. If time permits, the commander expands the fighting position to all four parts, including a hide and turret defilade location. The access ramp from the hide location to the hull defilade position usually provides turret defilade for a vehicle at some point on the ramp. This location can be marked with engineer tape and a chemical light so the driver knows when to stop. This fighting position affords maximum protection and maneuver for the BFV.

Vehicle Type	Position Dimension, ft ²			Equipment Hours ⁵ D7 Dozer/M9 ACE	Minimum Parapet Thickness at Base, ft
	Length	Width	Depth ^{4,6}		
HASTY¹					
M113-series carrier ³	22	14	6	0.6	8
M577 command post vehicle	22	14	9	0.8	8
M106 and M125 mortar carrier	22	16	7	0.7	8
DELIBERATE (Hull Defilade)					
M113-series carrier ³	22	14	6	0.6	8
M901 improved TOW carrier	22	14	7	0.6	8
M577 command post vehicle	22	14	9	0.8	8
M106 and M125 mortar carrier	22	16	7	0.7	
M2 and M3 fighting vehicle	26	16	7	0.8	
M1 main battle tank	32	18	5 1/2	0.9	
M60-series main battle tank	30	18	6	0.9	
M48-series battle tank	30	18	6	0.9	

Table 2-6. Dimensions of vehicle positions.

DELIBERATE (Access Route)

Each access route between positions or hide locations must have the same width as the hull defilade. Clearing times are planned using FM 5-34. Production time is determined by calculating the volume of soil needed to be moved (in cubic yards) and dividing by 100 bank cubic yards per 0.75 hour.

DELIBERATE (Hide Location)

Hide locations are made using natural terrain and concealment. Ground clearing times are planned using FM 5-34. The minimum width of the hide location is the same as the deliberate hull defilade. The hide position depth requirement is calculated by increasing the depth given in the **deliberate turret defilade** position by 15 percent.

DELIBERATE (Turret Defilade)

M113-series carrier ³	22	14	7 1/2	0.7	
M901 improved TOW carrier	22	14	9	0.8	
M2 and M3 fighting vehicle	26	16	10	1.2	
M1 main battle tank	32	18	9	1.5	
M60 series main battle tank	30	18	10	1.5	
48 series battle tank	30	18	10	1.5	

NOTES:

1. Hasty positions for tanks, IFVs, and ITVs not recommended.
2. Position dimensions provide an approximate 3-foot clearance around vehicle for movement and maintenance and do not include access ramp(s).
3. Includes M132 flamethrower and M103 Vulcan.
4. Total depth includes any parapet height.
5. Production rate of 100 bank cubic yards per 0.75 hour. Divide construction time by 0.85 for rocky or hard soil, night conditions, or closed hatch operations (M9). Use of natural terrain features will decrease construction time.
6. All depths are approximate and will need adjustment for surrounding terrain and fields of fire.

Table 2-6. Dimensions of vehicle positions (continued).

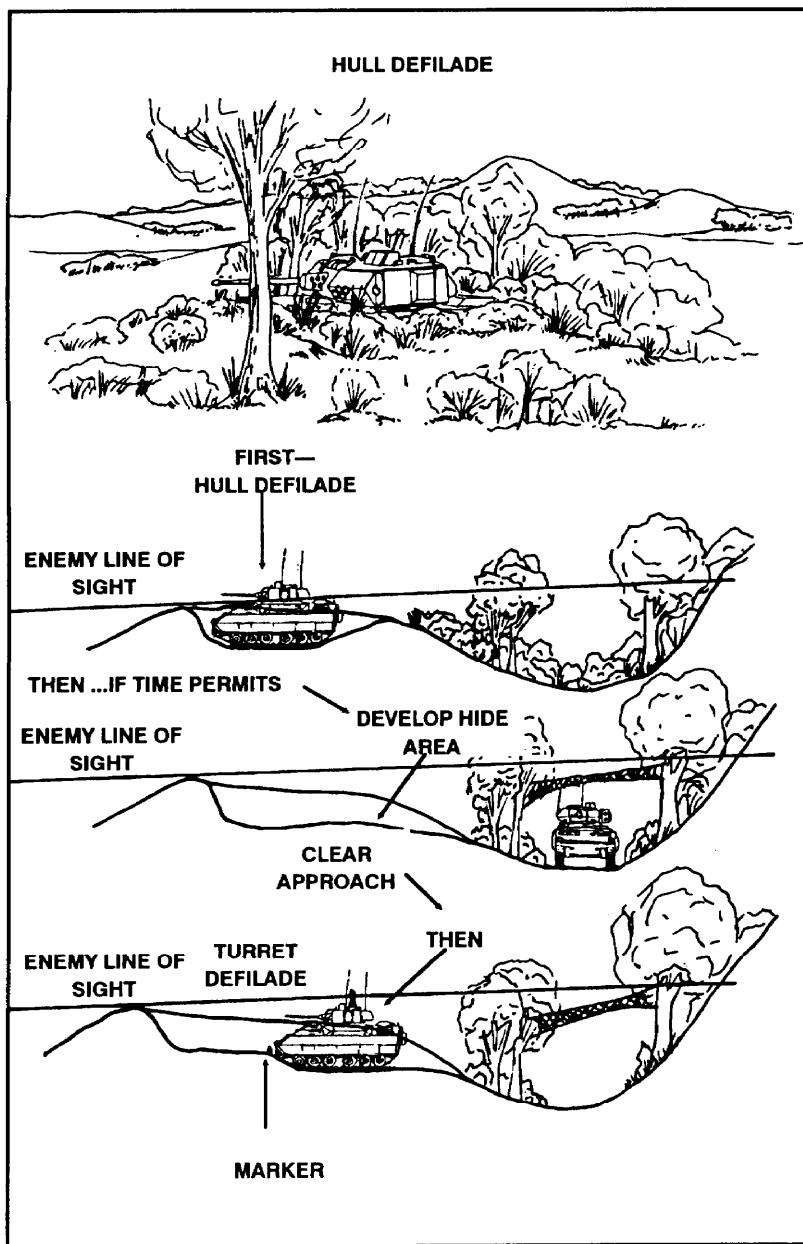

Figure 2-85. Developing deliberate fighting positions.

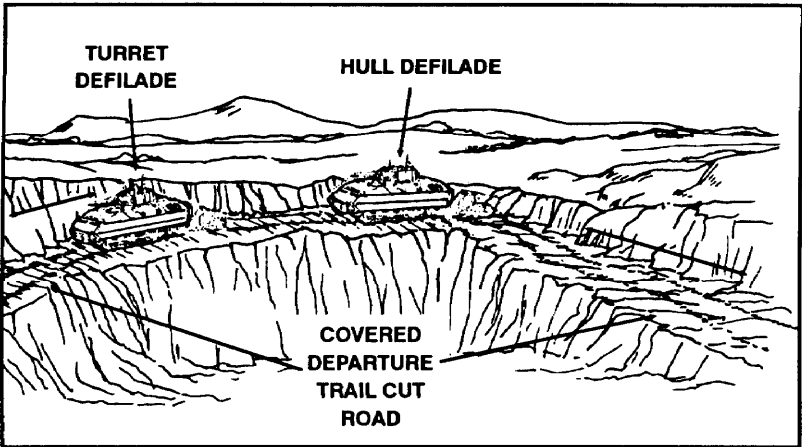

Figure 2-86. Enhanced natural position.

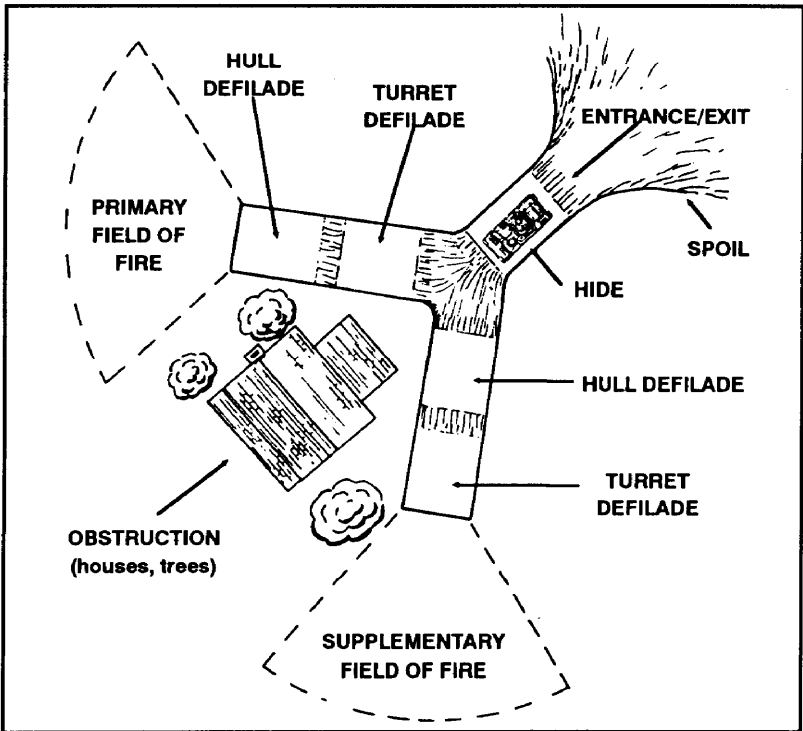

Figure 2-87. Top view of Y-shaped fighting position.

Section VI

OTHER OPERATIONS

Other tactical operations include retrograde (withdrawal, delay, and retirement) and special operations (linkup, stay-behind, relief in place, and passage of lines). Squads, along with BFV sections, and platoons conduct these operations as part of a larger force. A retrograde operation is an organized movement to the rear or away from the enemy.

2-29. WITHDRAWAL

In a withdrawal, a platoon disengages from the enemy and repositions for another mission. Platoons withdraw either not under pressure or under pressure.

a. **Withdrawal Not Under Pressure.** In this type of withdrawal, platoons normally serve as the detachment left in contact (DLIC) or as part of the DLIC (Figure 2-88). A DLIC is used to deceive the enemy into thinking that the entire force is still in position. As the DLIC, the platoon—

- Repositions BFV sections, squads, and weapons to cover the company's withdrawal (Figure 2-89).
- Repositions a squad and a BFV in each of the other platoon positions to cover the most dangerous avenue of approach into the position.
- Continues the normal operating patterns of the company and simulates company radio traffic.
- Covers the company withdrawal with planned direct BFV fire, dismounted infantry fire, and indirect fire if the company is attacked during withdrawal.
- Withdraws by echelon once the company is at its next position. The BFV is specially suited for this purpose because of its protection, mobility, and organic weapons systems.

b. **Withdrawal Under Pressure.** If the platoon cannot prepare and position the security force, it conducts a fighting withdrawal. The platoon disengages from the enemy by maneuvering to the rear (Figure 2-90, page 2-162). Soldiers, squads, or BFV sections not in contact are withdrawn first so they can provide suppressive fires to allow the soldier, squad, or BFV sections in contact to withdraw.

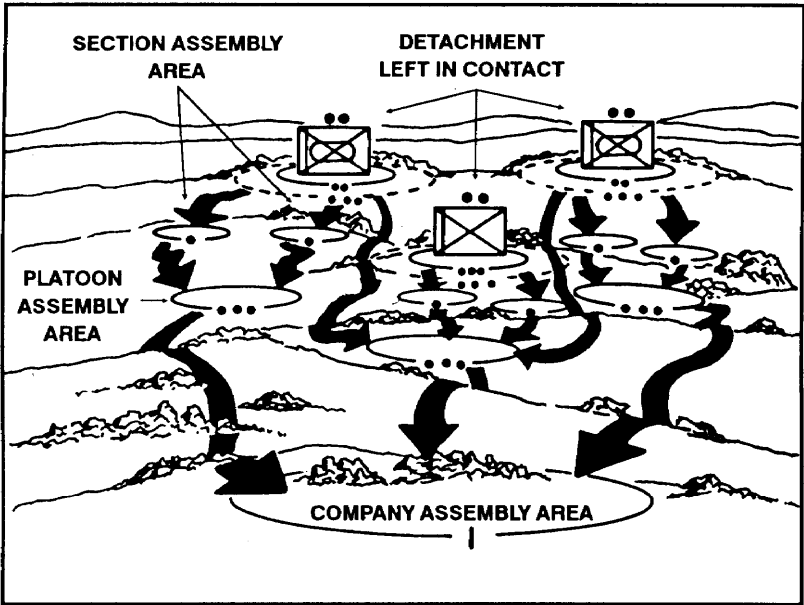

Figure 2-88. Withdrawal not under pressure.

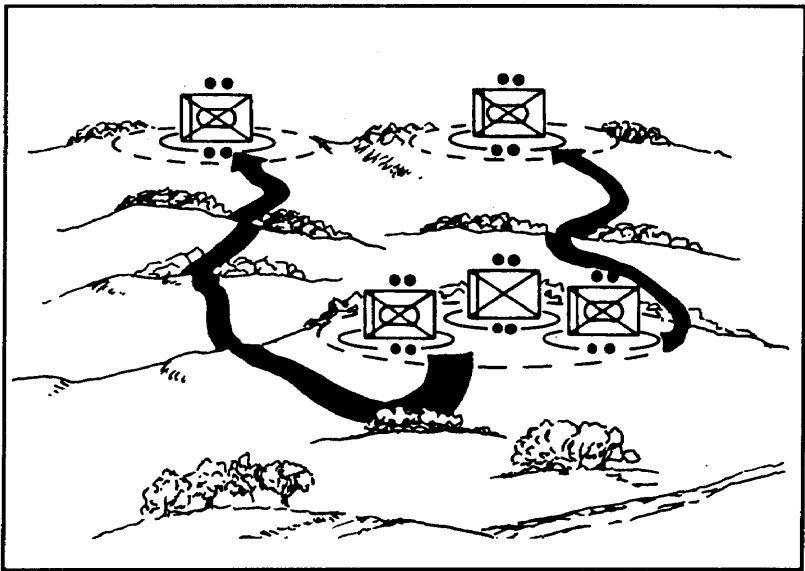

Figure 2-89. Repositioning of squads and section.

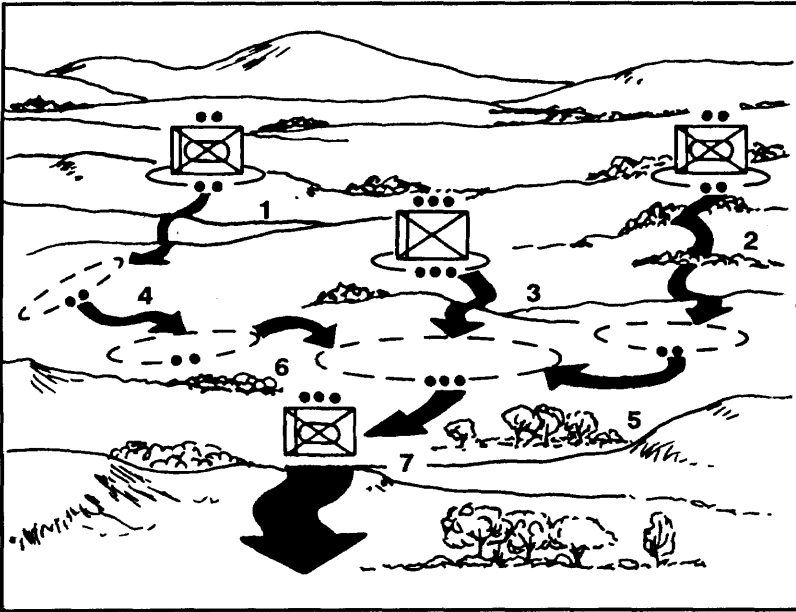

Figure 2-90. Bounding Overwatch to the rear.

c. **Disengagement.** Based on orders from the task force commander, the commander decides how long to retain defensive positions. The company or company team may be required to remain and fight as long as possible, or it may be required to disengage and displace to subsequent positions. A platoon, as part of a company or company team, may disengage to defend from another battle position, to prepare for a counterattack, to delay, to withdraw, or to prepare for another mission.

(1) **Fire and movement.** Fire and movement to the rear is the basic tactic for disengaging. All available fires are used to slow the enemy and allow platoons to move away. The commander may move his platoons and mass fires to stop or slow the enemy advance before beginning the movement away from the enemy.

(a) Abase of fire is formed to cover platoons or squads moving away from the enemy. One platoon or squad acts as the base of fire, delaying the enemy with fire or retaining terrain that blocks his advance, while other platoons or squads disengage. (Figure 2-91.)

(b) When moving platoons or squads get to their next position, they provide abase of fire to cover the rearward movement of forward platoons and squads. (Figure 2-92.)

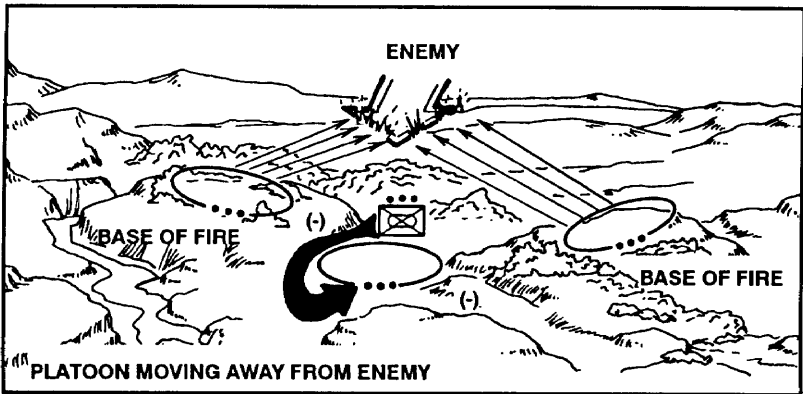

Figure 2-91. Breaking contact.

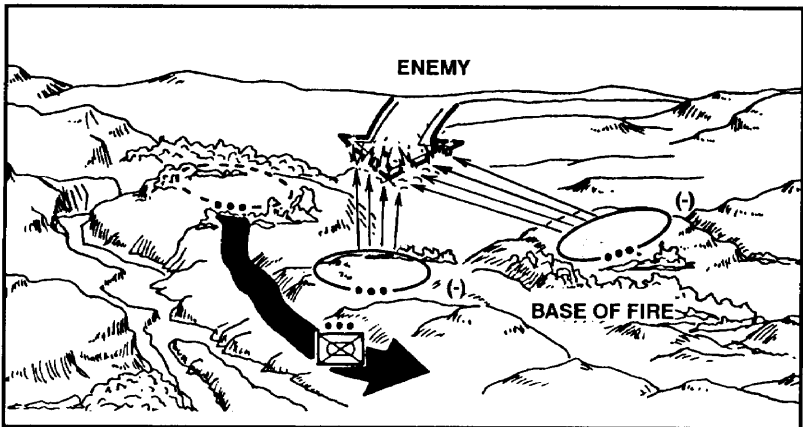

Figure 2-92. Rearward movement.

(c) Fire and movement is repeated until contact with the enemy is broken, the platoons pass through a higher level base-of-fire force, or the platoons are in the next position to resume their defense.

(d) Tactics used by the platoon to disengage from the enemy differs according to how the platoon is deployed, the commander's plan for disengagement, and other factors. The following actions apply in all cases.

- Maximum use is made of the BFV's firepower to cover rearward movement.
- BFVs should back out of position and move, keeping a terrain feature between the vehicle and the enemy.

- Turret weapons remain pointed in the direction of the enemy. Firing port weapons should be manned and ready to fire, especially from the rear firing ports. This is critical when the squad is operating at reduced strength.
- Rapid movement and effective base of fire enhance the mobility advantage and are key to a successful disengagement.

(2) **Plans for a disengagement.** Plans for a disengagement may be part of any defensive plan. When squads are deployed, a plan for rapid remounting must be made.

(a) When the platoon employs the BFV and dismount elements on separate positions, platoon remount points and routes to the remount points must be chosen. In addition, routes must be rehearsed. The platoon remount point can be near the dismount element position, near the BFV position, or between the two. (Figure 2-93.)

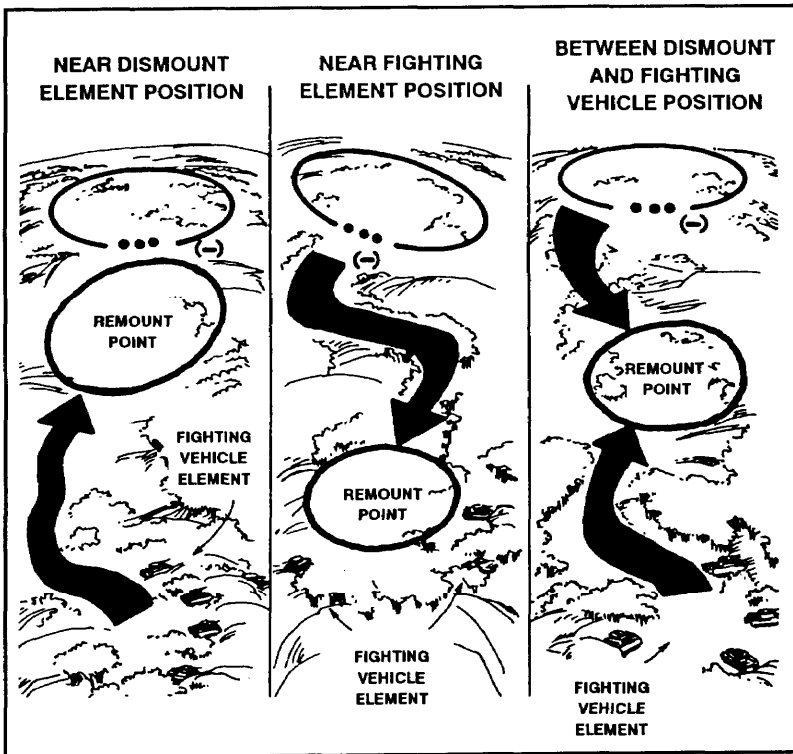

Figure 2-93. Platoon remount points.

(b) Within the remount point, covered positions for vehicles and dismounted infantry should be chosen that allow for easy remounting even during limited visibility. Squad leaders must ensure their men know where the remount point is, where the vehicle is at that point, and routes to the point. Routes to the remount point should be covered and allow speedy movement for both elements. Considerations for planning are—

- BFVs move faster and have more protection from small-arms fire and artillery fragments than dismounted soldiers.
- BFVs often shift from one firing position to another, so routes must be planned from each position to the remount point.

(3) ***Dismount element disengagement.*** When the dismount and fighting vehicle elements are separated, there are three ways the dismount element can disengage. Simultaneous disengagement (moving all teams at the same time) can be used when the element is covered by another force. When the dismount element must cover its own movement, it disengages by teams or by thinning the lines.

(a) ***Simultaneous disengagements.*** When the squads simultaneously disengage, they assemble and move as one element as fast as possible to the remount point, using proper movement techniques.

- Simultaneous disengagement is favored when rapid movement is critical, the disengaging element is adequately covered by overmatching fires, and the enemy has not closed on the dismount element or cannot fire effectively at it or there are obstacles to delay the enemy.
- Simultaneous disengagement can be used when the dismount element can move before the enemy can close on the position because of an obstacle or distance between the dismount element and the enemy; or when other platoons of the company, company team, or battalion task force are adequately covering the disengagement.

(b) ***Disengagement by fire teams.*** When the dismount element must cover its own movement, one squad stays in position as a base of fire. The rest of the dismount element moves to the rear. The squad left in position must fire into the entire element's sector to cover the movement of the other squad. Sectors of fire are adjusted to get better coverage of the element's sector. The squad that is moving may move by fire teams. (Figure 2-94, page 2-166.) The squad left in position disengages when the rest of the element is in position to cover them. Movement to the rear by alternating squad is continued until contact is broken. Once contact with the enemy is broken, the disengagement is complete and the dismount element moves to the remount point using proper movement techniques.

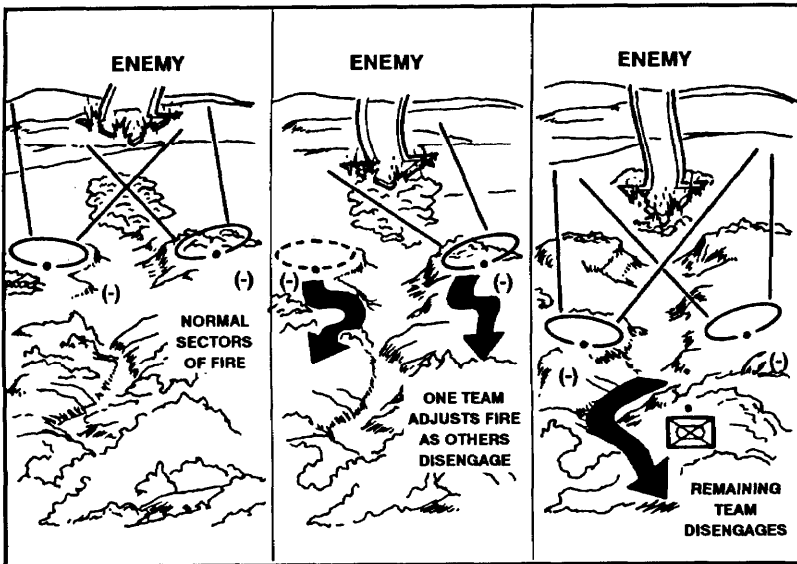

Figure 2-94. Disengagement by fire teams.

(c) *Disengagement by thinning the lines.* When disengaging by thinning the lines, selected soldiers from each fire team (often one soldier from each fighting position) disengage and move to the rear. The soldiers still in position become the base of fire to cover the movement. (Figure 2-95.)

(d) *Disengagement of squads when employed with the BFVs.* When BFVs and squads are employed on the same position, the squads normally move to the remount point while the BFVs provide a base of fire. The BFVs then quickly move to the remount point, link up with the infantry, load them, and move out. Squads use the disengagement techniques discussed earlier. The method selected is dictated by the enemy situation, terrain, fighting vehicle crews' ability to serve as a base of fire, and type and amount of overmatching fires.

(4) *Fighting vehicle element disengagement.* Because of the BFV's speed, firepower, and protection against small-arms fire and artillery shell fragments, it is usually best for the dismount element (when deployed) to disengage first while covered by the BFVs. If the BFVs are not in a position to support the dismount element by fire or if the dismount element is heavily engaged, the fighting vehicle element may disengage first and move to a position to assist the dismount element in

disengagement. Whichever method is used, there are two basic ways the vehicle element can disengage. If BFVs are covered by another force, simultaneous disengagement may be used. If BFVs must cover their own movement, it disengages by section. These methods are similar to those used by the dismount element.

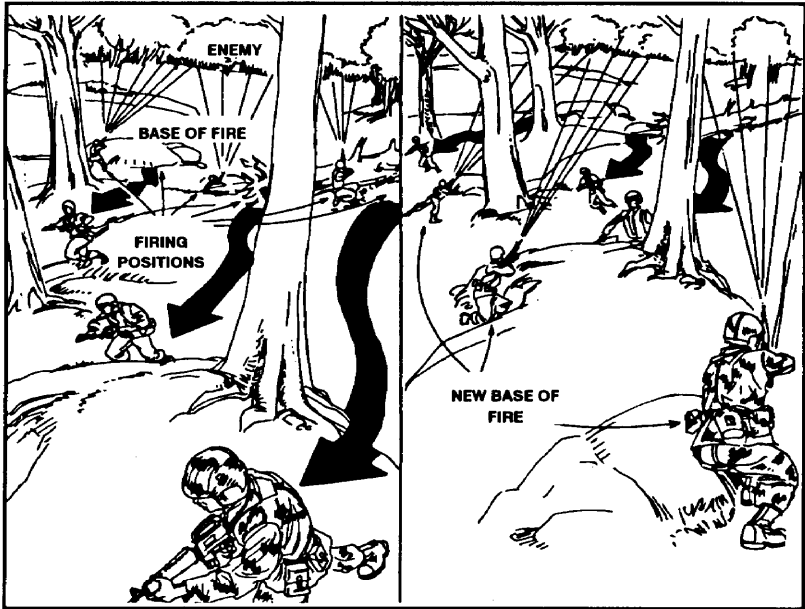

Figure 2-95. Disengagement by thinning the lines.

(a) *Simultaneous disengagement.* When BFVs disengage simultaneously, they move as a platoon as quickly as possible. This method is normally used when BFVs are covered by another force and speed is the most critical factor. If fire teams are already mounted, the entire platoon moves, using movement techniques, to a position designated by the commander. If fire teams are deployed, BFVs move to the remount point to pick them up, or they may attack the enemy by fire from a new position to allow the fire teams to disengage. (Figure 2-96, page 2-168.)

(b) *Disengagement by vehicle or section.* When BFVs must cover their own disengagement, one, two, or three vehicles can be left in position as a base of fire while the remainder move to the rear. BFVs left in position must cover the entire sector until moving vehicles reach positions they can use to provide a base of fire. (Figure 2-97, page 2-168.)

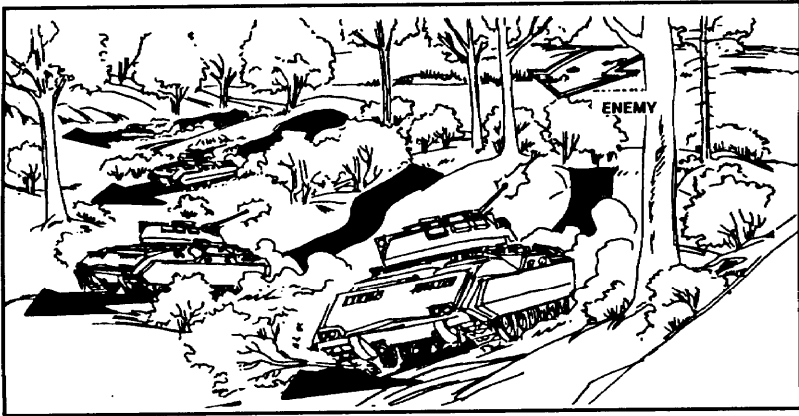

Figure 2-96. Simultaneous disengagement.

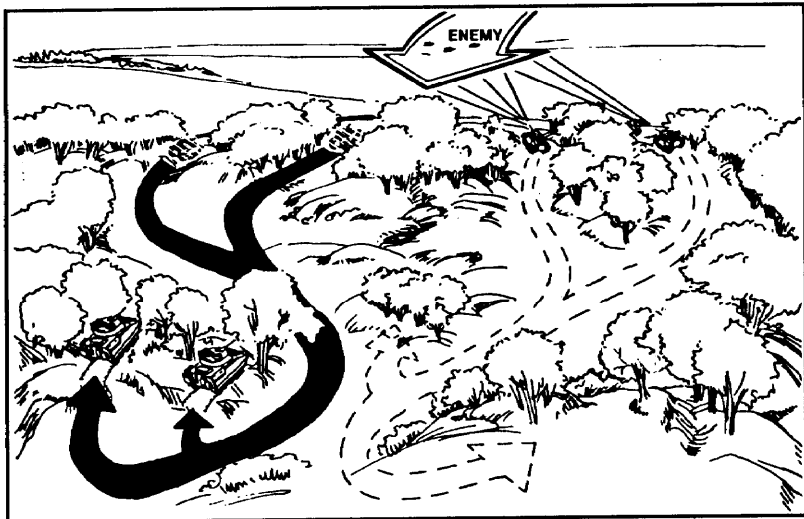

Figure 2-97. Disengagement by sections.

2-30. DELAY

In a delay, the platoon forces the enemy to slow its movement by forcing him to repeatedly deploy for the attack. Before the enemy assault, the delaying force withdraws to new positions. The squads or sections and platoons disengage from the enemy as described in a withdrawal under pressure. Once disengaged, a platoon moves directly to its next

position and defends again. The squads and platoons slow the advance of the enemy by shaking his morale, causing casualties and equipment losses. It can employ—

- Ambushes.
- Snipers.
- Obstacles.
- Minefields (to include phony minefields).
- Artillery and mortar fire.

2-31. RETIREMENT

A retirement is a retrograde operation in which a force not in contact moves away from the enemy. Platoons and squads or sections retire as members of larger units using standard movement techniques. A force that is not engaged with the enemy moves to the rear in an organized manner. Retirements usually involve tactical road marches along secured routes.

2-32. LINKUP

A linkup is a meeting of friendly ground forces. Linkups depend on control, detailed planning, and stealth. The linkup procedure begins as the platoon or squad moves to the linkup point. The steps of this procedure are as follows:

STEP 1. If using radio communications, the platoon reports its location using phase lines, checkpoints, or other control measures.

STEP 2. The first platoon at the site stops and sets up a linkup rally point about 300 meters from the linkup point or as terrain dictates.

STEP 3. The first platoon sends a security team to find the exact location of the linkup point. Depending on the size of the organization, the security team can be a strictly dismounted element or both a dismounted and mounted squad or section.

STEP 4. The security team clears the immediate area around the linkup point. It then marks the linkup point with the coordinated recognition signal. The platoon moves to a covered and concealed position to observe the linkup point.

STEP 5. The next platoon approaching the site repeats Steps 1 through 3. When its security team arrives at the site and spots the coordinated linkup point recognition signal, it gives the far recognition signal.

STEP 6. The first security team responds, and the second team advances to the first team's location. The teams exchange near recognition signals.

STEP 7. If entire units must link up, the second team returns to its unit's rally point and brings the unit forward to the linkup point. The first

security team guides the entire second unit to the linkup rally point. Both teams are integrated into the security perimeter.

STEP 8. When more than two units use the same linkup point, the first unit leaves a security team at the linkup point. They repeat the linkup procedure as other units arrive.

2-33. STAY-BEHIND OPERATIONS

Stay-behind operations can be used as a part of defensive or delay missions. In the defense once the enemy's combat units have passed, his weakest point (CS and CSS units) can be attacked.

a. **Types.** The two types of stay-behind operations are unplanned and deliberate.

(1) **Unplanned.** An unplanned stay-behind operation is one in which a unit finds itself cut off from other friendly elements for an indefinite time without specific planning or targets and must rely on its own organic assets.

(2) **Deliberate.** A deliberate stay-behind operation is one in which a unit plans to operate in an enemy-controlled area as a separate and cohesive element for a certain amount of time, or until a specified event occurs. This requires extensive planning. Squads and sections and platoons conduct this type of stay-behind operation only as part of larger units.

b. **Planning.** The troop-leading procedure applies to stay-behind operations. Planners must pay strict attention to the following.

(1) **Task organization.** The stay-behind unit includes only the soldiers and equipment needed for the mission. It needs only minimal logistics support and can provide its own security. It must be able to hide easily and move through restrictive terrain. Therefore, BFVs may or may not be a part of the stay-behind forces.

(2) **Reconnaissance.** This is most important in a stay-behind operation. Reporting tasks and information requirements can include suitable sites for patrol bases, hide positions, OPs, caches, water sources, dismounted and mounted avenues of approach, kill zones, engagement areas, and covered and concealed approach routes.

(3) **Combat service support.** Because the stay-behind unit will not be in physical contact with its supporting unit, supplies of rations, ammunition, radio batteries, water, and medical supplies are cached. Provisions for casualty and EPW evacuation depend on the company and battalion plans. BFVs in the stay-behind forces have some advantages however, BFVs do cause some CSS planning problems.

(4) **Deception plan.** Most stay-behind operations are setup covertly. The enemy must be misled during this effort to cause him to act in a

manner favorable to the unit's plan of action. COMSEC is a special concern; radio transmissions must be brief and encoded.

(5) **Concept of the operation.** Units usually operate in small groups in their own areas. The actual concept, however, depends on the commander's intent.

2-34. RELIEF IN PLACE

A relief in place is an operation in which a unit is replaced in combat by another unit. The incoming unit assumes responsibility for the combat mission and the assigned sector or zone of action of the outgoing unit. Normally platoons conduct reliefs in place as part of a larger unit.

a. **Coordination.** Platoon responsibility is usually limited to the detailed coordination between key personnel and their counterparts. Leaders must coordinate the following items as a minimum.

(1) **Reconnaissance.** Leaders must reconnoiter different routes into and out of the position; assembly areas; logistics points; primary, alternate, and supplementary positions; obstacles; immediate terrain; and when possible, patrol routes and OP locations.

(2) **Plans and tasks.** The outgoing leader must provide copies of the unit sector sketch, fire plan, range cards for all vehicles, weapons, barrier plan, minefield records, counterattack plans, and plans for any other tasks that must be performed as part of the defense.

(3) **Relief plan.** Both leaders must know which method and sequence of relief has been prescribed in the company order, and how they will execute the plan. They must—

- Know if their platoons will execute the relief by squads, by BFM (section), or as a complete platoon (method). Platoons may also execute the relief by occupying adjacent terrain or terrain in depth rather than by relieving soldiers and units in position.
- Know the order of relief for platoons within the company (sequence); include the relief of OPs by patrol.
- Coordinate the use of vehicle guides, signals, challenge and password, and passage of responsibility for the mission and control of the unit (normally when most of the incoming unit is in place).

(4) **Exchange of equipment.** Leaders coordinate the exchange of phones or switchboards, and emplaced munitions (if included in the relief order). Units do not exchange radios or radar equipment (if attached).

(5) **Exchange of supplies.** Leaders identify numbers and classes of supplies to be left behind and their location to include sensors, construction materiel, wire, and any supplies that might slow the movement of the outgoing platoon.

b. Execution. During the execution both platoon leaders should collocate at the outgoing unit's CP. The leader of the outgoing unit remains responsible for the defense of the area until most of the incoming unit is in position. If the enemy attacks during the relief, the leader who has responsibility for the position at the time is in control. The other leader assists with assets under his control as directed. Squad leaders physically walk soldiers to positions and trade them out on a one-for-one basis. They allow time for outgoing soldiers to brief their reliefs on their positions, range cards, and other pertinent information. Key weapon systems replacement is a higher priority than personnel replacement. All leaders report completion of their portion of the relief as soon as possible.

2-35. AIR ASSAULT OPERATIONS

Through the conduct of combat operations, Bradley platoons may be required to conduct air assault operations as part of the higher headquarters commander's tactical plan. Successful air assault execution is based on a careful analysis of METT-T and detailed, precise reverse planning. The basic plans that comprise the reverse planning sequence and developed for each air assault operation are ground tactical plan, landing plan, air movement plan, loading plan, and staging plan. These plans are normally coordinated and developed by the air assault task force (AATF) staff to make the best use of available time. If time is limited, planning steps may be compressed or conducted concurrently; detailed within plans and orders may be SOPs or lessons learned in training (previous training and the development of SOPs cannot be overemphasized). The battalion is the lowest level that has sufficient personnel to plan, coordinate, and control an air assault operation. When company-size or lower operations are conducted, the bulk of the planning takes place at battalion or higher headquarters. Bradley platoon leaders must use FM 90-4 for more detailed information when planning air assault operations. Although it is not the highest priority training in the mechanized infantry battalion, air assault operations and mission task should be included in the platoon METL. To ensure that an air assault is executed in an effective and efficient manner, the platoon leader and platoon sergeant have specific responsibilities they must perform, which are outlined in the platoon SOP (IAW FM 90-4).

a. Ground Tactical Plan. The foundation of a successful air assault operation is the commander's ground tactical plan, around which subsequent planning is based. The ground tactical plan specifies actions in the objective area to ultimately accomplish the mission and address subsequent operations. The ground tactical plan contains

essentially the same elements as any other infantry attack but differs in that it is prepared to capitalize on speed and mobility to achieve surprise.

b. **Landing Plan.** The landing plan must support the ground tactical plan. This plan sequences elements into the area of operations ensuring that platoons arrive at designated locations and times prepared to execute the ground tactical plan.

c. **Air Movement Plan.** The air movement plan is based on the ground tactical and landing plans. It specifies the schedule and provides instructions for air movement of soldiers, equipment, and supplies from PZs and LZs.

d. **Loading Plan.** The loading plan is based on the movement plan. It ensures soldiers, equipment, and supplies are loaded on the correct aircraft. Platoon integrity is maintained when aircraft loads are planned. Cross-loading may be necessary to ensure survivability of command and control assets and the mix of weapons arriving at the LZ are ready to fight. The platoon leader or squad leader should always ensure that the aircraft is loaded so that dismounting soldiers react promptly and contribute to the mission accomplishment. The platoon leader must have a bump plan. A bump plan ensures that essential soldiers and equipment are loaded ahead of less critical loads in case of aircraft breakdown or other problems.

e. **Staging Plan.** The staging plan is based on the loading plan and prescribes the arrival time of ground units (soldiers, equipment, and supplies) at the PZ in the proper order of movement. The staging plan also includes the disposition of the vehicles left in the staging area and the platoon's linkup plan on return from their air assault mission.

(1) **Disposition of vehicles.** The platoon leader must develop a security plan in the staging area for the vehicles until the air assault mission is completed and the platoon returns to the LZ. The security plan can be as simple as a coil or herringbone formation for the platoon, or the platoon may be part of a company modified perimeter defense. Instructions for link up of the platoon with its vehicles will also be included.

(2) **Linkup of vehicles.** The platoon leader's linkup plan must be just as detailed as the staging and loading plan. To simplify the linkup, the platoon leader must ensure that platoon integrity is maintained as much as possible. The platoon leader or company commander should designate a linkup point for each unit to link up with their vehicles on landing. As the aircrafts land, the unit's immediately move to their linkup point, mount their vehicles if required, and prepare to continue the mission.

Section VII

FIRE SUPPORT

Infantry platoons plan indirect fires to suppress, isolate, obscure, neutralize, destroy, deceive, or disrupt enemy forces. The fire planning process is used to plan direct and indirect fires in support of offensive and defensive operations. Normally, battalions and companies conduct fire support planning and send a target list to the platoons. Platoon leaders and their FOs review the indirect fire plan to determine the need for additional targets in their area of responsibility. If a need exists for additional targets, the platoon leader requests through fire support channels that those targets be included in the company fire plan. The platoon leader, however, does not wait to receive the company fire plan. He begins fire planning as soon as possible and integrates his fire plan into the company fire plan through fire support channels.

2-36. OFFENSIVE FIRE SUPPORT PLANNING

The offensive fire support plan is developed at the same time as the company's scheme of maneuver. The FO integrates the indirect fires, based on the platoon leader's guidance, to support the platoon's maneuver throughout the operation.

a. Fires are planned to support all phases of the attack in front of, on, and behind the objective. Those planned in front and on the objective support the approach, deployment, and assault of the attacking force. Fires planned beyond the objective support the consolidation and disrupt reinforcing and counterattacking forces. Fires are planned on all known or suspected enemy locations. Indirect fires are also planned on likely avenues of approach or on prominent terrain features.

b. The platoon uses smoke or white phosphorus to screen itself when moving mounted or dismounted across danger areas, when breaching obstacles, or when obscuring known or suspected enemy positions.

2-37. DEFENSIVE FIRE SUPPORT PLANNING

The platoon leader and the FO plan indirect fire to support the defensive scheme of maneuver. Fire support considerations at platoon and squad level include final protective fires (FPF) and effect of smoke and illumination on defending forces.

a. Fires are planned on all likely enemy positions and on areas the enemy may use in the attack such as OPs, support positions, avenues of approach, assault positions, dead space, flanks, defiles, and obstacles.

They are also planned in front of, on top of, and behind friendly positions to stop likely penetrations or to support a counterattack.

b. Final protective fires are barriers of fire planned on the most dangerous enemy avenue of approach to provide immediate close protection for defending soldiers and usually tied to the defensive barrier or engagement area plans. The purpose of FPF is to support the defeat of the enemy's close assault against a defensive position. Therefore, it must be integrated with the platoon and BFV direct fire plan and obstacle plan. Once called for, FPF are fired continuously. For this reason, the company commander often retains the control of FPF. FPF must not be tailed for until the enemy is in close assault of the defensive position. All platoon weapons fire along their final protective line or principle direction of fire while the FPF are being fired.

c. Defending platoons use smoke sparingly. Most often defending platoons use smoke to screen their movement out of a position or to obscure the enemy's view of friendly force efforts in preparing to defend.

d. Illumination provides artificial lighting to the defending force. It should be employed on top of or behind the attacking force instead of on top of the defending force. Platoons use flares, illumination grenades, and mortar and artillery illumination rounds. Flares provide early warning of the enemy approach and help to pinpoint his location. Grenade launcher illumination rounds provide flexible and immediate illumination, while mortars and artillery provide sustained illumination. The company commander normally retains the control of illumination in the defense.

2-38. TECHNIQUES OF INDIRECT FIRE CONTROL

The positioning of the FO and the proper procedures used to call for fire are critical in order to receive immediate indirect fire.

a. **Forward Observer Positioning.** The platoon leader and FO should always be together during execution. This ensures close synchronization of the scheme of maneuver and plan of fire support. The platoon leader is responsible for both, but he concentrates on maneuver and direct fires. The FO is the platoon leader's principle assistant in managing indirect fires. They eat, sleep, and fight together. Each has separate requirements to communicate with higher headquarters but will do so usually from the same location. The FO should ride in the platoon leader's BFV. The platoon leader and FO identify primary and alternate positions to ensure continuous observation during limited visibility conditions. The FO verifies and rehearses FM radio

communications as the tactical situation permits. Squad and BFV section leaders may be designated to observe targets and call for fire.

(1) The platoon leader must ensure that the FO knows the overall concept of the operation to include the following:

- The location and description of the targets to engage.
- The terminal effects required (destroy, delay, disrupt, suppress) and the purpose.
- The communication means, radio net, call signs, and fire direction center to use.
- When or under what circumstances to engage targets.
- The relative priority of targets.
- The method of engagement and method of control to be used in the call for fire.

(2) If the platoon leader and the FO cannot see the targets and trigger lines or TRPs under the visibility conditions expected at the time the target is to be fired, they immediately notify the company. The company commander and fire support team (FIST) evaluate the situation and notify higher headquarters. The planning headquarters then plans a new target at a location that meets the commander's purpose for fire support or higher headquarters devises alternate means to assist the company and platoon in executing indirect fire action at engagement and trigger lines.

b. **Call for Fire.** A call for fire is a message prepared by an observer. It has all the information needed to deliver indirect fires on the target. Any soldier in the platoon can request indirect fire support by use of the call for fire.

(1) Calls for fire must include—

- Observer identification and warning order-adjust fire, fire for effect, suppress, and immediate suppression (target identification).
- Target location methods—grid, polar, and shift from a known point.
- Target description—give a brief description of the target using the acronym “SNAP” (Size/shape, Nature/nomenclature, Activity, Protection/posture).

(2) A call for fire may also include the following information (optional elements):

(a) *Method of engagement.* The method of engagement consists of the type of adjustments, danger close, trajectory, ammunition, and distribution.

(b) *Method of fire and control.*

- At my command.
- Cannot observe.
- Time on target.
- Continuous illumination.
- Coordinated illumination.
- Cease loading.
- Check firing.
- Continuous fire.
- Repeat.

(c) *Refinement and end of mission.*

- Correct any adjustments.
- Record as target.
- Report battle damage assessment.

(3) Examples of call for fire follow:

(a) *Grid.*

“_____ this is _____ adjust fire/fire for effect, over.”

“Grid _____, over.”

“Target (description) _____, over.”

NOTES:

1. Determine a six-digit grid for the target.
2. Determine a grid direction to the target and send after the call for fire but before any subsequent corrections.
3. Determine the grid direction to the target.
4. Determine a distance from the observer to the target.
5. Determine if any significant vertical interval exists.
6. Fire direction center must have OP location.

(b) *Shift from a known point.*

“ _____ this is _____ adjust fire/fire for effect, shift (target number/registration point number), over.”

“Direction _____ Right/Left _____, Add/Drop _____, Up/Down _____, over.”

“(Target description) _____, over.”

NOTES:

1. Determine the grid direction to the target.
2. Determine a lateral shift to the target from the known point.
3. Determine the range shift from the known point to the target.
4. Fire direction center must have known point location and target number.

2-39. TECHNIQUE FOR DIRECT-FIRE SUPPORT FROM BFVs

The platoon leader must have the flexibility and capability to place direct fire from BFVs on key targets throughout combat operations. The technique used to do this is a modification of the six elements of the BFV fire command (FM 23-1).

1. **Alert.** Alert the mounted element leader of an immediate engagement. “A34 (PSG). This is A31 (platoon leader), engagement; over.”

2. **Weapon/Ammunition.** Inform the mounted element leader of the weapon or ammunition to be used. “Engage with coax.”

3. **Description.** Identify the target for the mounted element leader. “Dismounted squad in the tree line to my immediate front.”

4. **Support Position/Direction.** Guide the mounted element into the support position and on the target. “Move 100 meters to your left and shift fires 200 meters left of TRP 2.”

5. **Range.** Give the range to the target. “The squad is 600 meters to your front from that position.”

6. **Execution.** Call for fire. “Fire when in positions, over.”

Section VIII

COMBAT SERVICE SUPPORT

CSS operations at platoon level are a vital part of infantry operations. They consist of logistical and personnel functions. CSS is integrated into the tactical planning process from the starting phases of operations. Well-planned and executed CSS is a large part of mission accomplishment and success of combat operations. Like CS, CSS is a combat multiplier. Soldiers well supplied with food, water, ammunition, shelter, and medical care are more successful in accomplishing their missions than those who are not.

2-40. PLANNING

The company headquarters plans, coordinates, and executes CSS functions for the company. The mechanized platoon leader coordinates the platoon's CSS effort, which consists of maintenance, supply, personnel, and medical services. The platoon leader stays abreast of the platoon's CSS status and, along with the platoon sergeant, plans and executes CSS functions. The platoon sergeant and squad leaders supervise the performance of most of the CSS tasks in the platoon. Platoon SOPs stipulate CSS tasks and procedures for their accomplishment. They should standardize as many of the routine and recurring CSS operations as possible. Since most CSS for the platoon comes from the company and battalion, platoon SOPs should include procedures for coordination with the various CSS cells at those levels.

2-41. RESUPPLY OPERATIONS

Mechanized infantry platoon and company supplies are delivered by battalion CSS elements. The platoon leader, platoon sergeant, and squad leaders must know the supply status of the platoon and the squads at all times, and they must have a plan to replenish supplies. Platoon and squad SOPs should establish levels of depletion for specified items of supply (for example, ammunition and fuel). This is to preclude running out of critical supplies at the decisive point in an operation. All soldiers and leaders must report supply status once that level is reached. The platoon sergeant combines requests from the squads and forwards them to the ISG who operates on the battalion administrative/logistic net. Logistics reports, when required, are sent to the commander. Most resupply requests take a lot of time to transmit so line numbers or SOP codes should be

used to save time and maintain operational security, especially when operating on a nonsecure net. Requests for supply are filled upon receipt or during the next resupply operation, depending on urgency. Resupply and refueling should be accomplished at every opportunity. One of the most critical resupply functions is water. Even in cold areas, all personnel must drink at least 2 quarts of water a day to maintain efficiency. Water can be resupplied by collecting and filling all the water cans from the vehicles or by moving a water trailer with planned resupply operations.

a. When water is not scarce, leaders must urge soldiers to drink water even when not thirsty. This is due to the body's thirst mechanism, which does not keep pace with the loss of water through normal daily activity. The rate at which dehydration occurs depends on the weather conditions and the level of physical exertion.

b. If water is in short supply, soldiers must use it sparingly for hygienic purposes. To conserve water, a centralized heating point can be established to provide warm MREs. Water used for coffee or tea may be counterproductive because both increase the flow of urine. Soups are an efficient means of providing both water and nutrition when water is scarce, particularly in cold weather when heated food is desirable.

c. In most environments, water is available from natural sources. Soldiers should be trained to find, treat (chemically or using field expedients), and use natural water sources. The use of iodine tablets is the most common and easiest method to treat water. (Iodine tablets that are various shades of gray or have softened should not be used.) (See FM 21-10 and FM 21-76 for more information.)

2-42. RESUPPLY TECHNIQUES

Platoon resupply is mainly a "push" system. The platoon receives a standard package of supplies based on past usage factors and planning estimates. Resupply of all classes of supply is usually conducted in one of two ways or a combination of both if certain vehicles cannot be moved.

a. Whatever resupply technique they select, leaders must ensure security at all times.

(1) The first technique is the quickest, safest, most efficient and thorough technique for resupply. It is the service-station technique (Figure 2-98); the company sets up a resupply point behind the company and platoons' positions. Each platoon as a whole or by sections quickly rotates through refueling and rearming, picks up other supplies and rations, and receives medical and maintenance support.

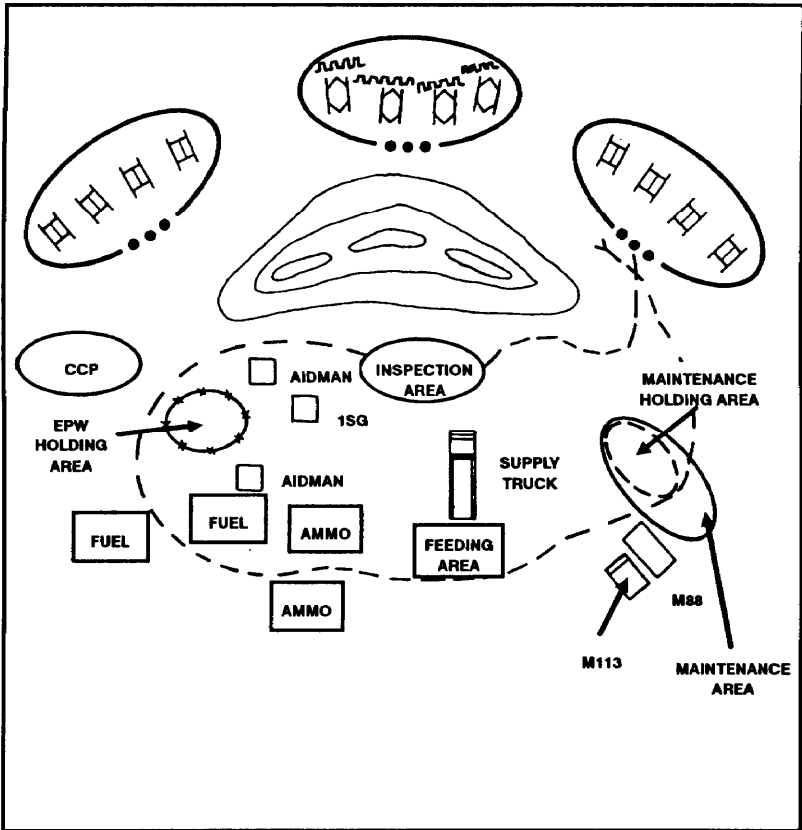

Figure 2-98. Service-station technique.

(2) The second technique is the tailgate technique of resupply (Figure 2-99, page 2-182). This is used when a vehicle cannot be moved from its position. Ammunition, fuel, POLs and other supplies are moved to the rear of each vehicle's position providing resupply in place. This technique should be used when enemy contact is not likely. It also takes the most time.

b. Emergency resupply may be conducted when the platoon cannot wait for scheduled resupply operations (normally a result of combat). Emergency resupply may involve Classes III, V, VIII, and NBC equipment, and is often conducted while in contact with the enemy.

c. Pre-positioning supplies may be required in some defensive operations but normally only Class V items are pre-positioned.

All leaders should verify the locations and prioritize the prestockage of these sites during their reconnaissance and rehearsals. Pre-positioned ammunition must be located in covered and protected positions away from vehicles and individual fighting positions to prevent its destruction and friendly casualties as a result of explosions.

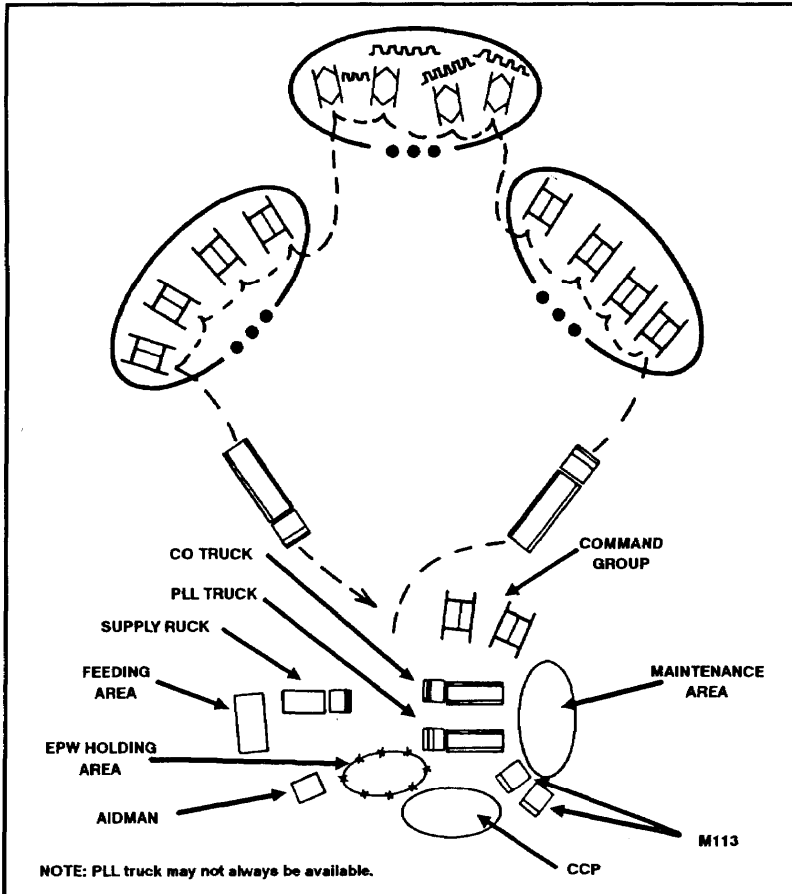

Figure 2-99. Tailgate technique.

2-43. OTHER RESUPPLY CONSIDERATIONS

Other BFV resupply considerations include ammunition and missiles, POL, rations and water, and repair parts.

a. **Ammunition and Missiles.** BFVs require many types and quantities of ammunition and missiles. These can be rapidly expended. BCs and squad leaders must control ammunition and inform the platoon leader or platoon sergeant on the amount of ammunition and missiles remaining, so accurate and timely requests for resupply can be submitted. Redistribution of ammunition after contact is critical to maintaining the fighting capability of the platoon.

(1) Resupply of ammunition and missiles is based on a report of expenditures submitted to the company XO or first sergeant. Ammunition is sent forward from the battalion trains to logistic release points (LRPs). At the LRPs, company personnel assume control and lead the supply vehicles to platoon areas.

(2) Wheeled vehicles, armored vehicles, and helicopters can be used for ammunition resupply. The platoon leader should know what type of transportation is being used. This affects his selection of location, security requirements, and time required to complete resupply.

(a) If wheeled vehicles are used, the platoon leader must select a location that has suitable routes for the wheeled vehicles.

(b) If armored vehicles are used, it may be possible to resupply the platoon in position.

(c) If helicopters are used, an adequate LZ must be selected to the rear of the position. It must be secured before the helicopter arrives. Resupply may require more time because the ammunition might have to be hand-carried off the LZ.

(3) A BFV crew should perform certain steps before being resupplied with ammunition. These include—

(a) Completely filling the ammunition cans (ready boxes) for the 25-mm gun and the 7.62-mm coaxial machine gun.

(b) Repositioning the remaining stowed ammunition to leave the easy-to-stow areas open. For example, if the 25-mm ammunition stowage space under the floor plates is empty, it should be filled with ammunition stowed on the sponsons.

(c) Loading remaining TOWs, if the launchers are empty.

(d) Filling all empty magazines for M16 rifles and the firing port weapons.

(e) Ensuring that adequate tools, such as wire cutters and crowbars, are readily available to open the ammunition boxes.

(f) Determining who provides security, how the ammunition is to be divided and how the ammunition is to be unloaded and stowed. These actions may be prescribed in the SOP.

b. Petroleum, Oil, and Lubricants. BFV fuel tanks should be topped off any time the tactical situation allows. Normally, the platoon sergeant requests POL through the XO or first sergeant. The request should tell them how much fuel is needed and where and when to refuel (six-digit grid coordinates).

(1) The BFV has a 175-gallon fuel capacity. This gives it about a 300-mile cruising range. The platoon leader should keep this in mind when planning to refuel, because the amount of fuel required directly affects refueling time. He also must be aware that the cruising range is an approximation, and that terrain and weather influence fuel consumption.

(2) When refueling time is limited, the platoon leader must choose between topping off the BFVs that need the most fuel and putting a limited amount in each BFV. If the fuel tanker can move to the BFV it is best to put a limited amount in each BFV. When the BFVs have to move to a central refueling point, the BFVs requiring the most fuel are moved first and topped off. The others are then topped off at the first opportunity.

(3) At times, the BFVs may have to be topped off using 5-gallon cans. This is slow, so extra time should be allowed. The fastest way to refuel from cans is for each squad to form a line to pass the cans from the fuel-carrying vehicle to the BFV.

c. Rations and Water. Each crew and fire team carries combat rations and water on its BFV. The BFV has designated storage space for rations. If more rations are required, they can be stowed in the bustle rack or secured inside the BFV. When the situation allows, hot meals prepared by battalion mess teams may be served to the platoon. Rations and water supplied to the platoon are based on personnel strength. The platoon leader or platoon sergeant may submit special requests IAW platoon SOP.

d. Repair Parts. Repair parts are issued in response to specific requests or by direct exchange. The battalion maintenance platoon keeps each company's PLL. The company maintenance team carries the supported unit's PLL to expedite repairs. The company is authorized to keep on hand high-demand repair parts for weapons, radios, and vehicles based on the PLL.

(1) A limited number of armament spare parts are stowed on the BFV. This includes a barrel assembly with case and ruptured cartridge extractor for the 7.62-mm coaxial machine gun. Also included are two bolt assemblies, two bolt cam pins, two retaining pins, and a maintenance equipment ease for the FPWs.

(2) Two track blocks and a drift pin are attached to the outside deck of the BFV. A water barrier repair kit is provided. Two vehicle tool bags are in the engine compartment, and one gun tool bag is stowed in the driver's area. These tools are required to perform operator maintenance. (See the TM for a list of tools.)

e. **Other Supplies.** Although each mechanized infantry platoon has a large amount of equipment, it requires frequent resupply to accomplish its mission. Periodic checks by leaders ensure that equipment is accounted for and ready to use. Low-use items (such as drain plugs, NBC equipment, and certain tools) can easily be lost or damaged; therefore, they should be rechecked often to ensure they are on hand and usable.

(1) The battalion medical platoon provides medical supplies. The aidman supporting the platoon assists the platoon sergeant and squad leaders in preparing a consolidated list of required medical supplies. These include not only medical supplies needed by the aidman, but also those used by each soldier such as first-aid dressings, water purification tablets, and foot powder. The platoon sergeant or the aidman passes the list to the company evacuation team. They take the list to the battalion medical platoon where the medical supplies are provided.

(2) Tools, CTA 50-900 equipment, batteries, and other expendable are obtained through the company supply sergeant. Normally, maps are supplied through the company XO or first sergeant.

2-44. MAINTENANCE

Maintenance includes unit and direct support maintenance and recovery. It is a continuous process that starts with preventive measures taken by the operator and crew and continues through repairs by maintenance personnel. Proper maintenance is the key to keeping equipment and material in serviceable condition. It includes inspecting, testing, servicing, repairing, requisitioning, recovering, and evacuating. Repair and recovery are done as far forward as the situation allows. When equipment cannot be repaired on site, it is evacuated to the rear only as far as necessary for repair.

a. **Maintenance Responsibility.** A platoon leader is responsible for the maintenance of his equipment. He must be able to perform preventive maintenance, know what to do when a maintenance problem arises, know how to inspect, and know how to train his operators. Cross-training is critical; the loss of one individual must not adversely affect the combat readiness of the squad or platoon. The platoon leader's responsibilities include training operators, inspecting, assigning tasks within the platoon, and providing adequate time to perform

required maintenance. He also supervises all maintenance periods, coordinates support required from higher echelons, informs the chain of command of major problems, and follows up on maintenance being performed outside the platoon.

b. Unit Maintenance. Unit maintenance is the responsibility of the unit that is assigned the equipment. It is performed by operators, crews, and mechanics from the battalion's maintenance platoon.

(1) Operator and crew maintenance includes proper care, use, and operation of equipment. The BFV driver and other crew members perform daily services on the vehicle and all other assigned equipment such as weapons, night vision devices, and NBC gear. These services include inspecting, servicing; tightening; minor lubricating, cleaning, and preserving; and adjusting tools and equipment as prescribed by technical manuals. Crew members must record on DA Form 2404 (Equipment Inspection and Maintenance Worksheet) all equipment faults they cannot correct or those they can correct by replacing a part. The driver's and gunner's reports are the main way to convey information about equipment faults to the platoon leader and to unit maintenance personnel.

(2) PMCS for the turret, automotive, and weapon systems should be conducted before, during, and after operation. This includes detailed daily service as prescribed in the TM and lubrication order.

(3) The gunner should be responsible for maintaining the turret to include weapon systems, maintaining DA Form 2408-4 (round count) on the 25-mm gun and TOW, and knowing when replacement on weapon parts are required such as the 25-mm gun firing pin assembly (8,000 rounds) and breech (25,000 rounds). The driver is responsible for completing DA Form 2404, for performing automotive checks, and for operating the BFV.

(4) When the operator identifies a problem that is beyond his level of maintenance, the battalion maintenance platoon must be notified to isolate and correct it. The battalion maintenance platoon has five company maintenance teams that establish support relationships with the companies. Company maintenance teams have trained mechanics who are authorized to do unit maintenance. Battalion maintenance personnel have test equipment that allows them to rapidly diagnose faults in the system. With the BFV's provision for rapid modular replacement, many faults can also be rapidly corrected. If battalion maintenance cannot repair the item, they arrange to have it checked by DS maintenance.

c. **Direct Support Maintenance.** DS maintenance is performed by the forward support battalion that normally supports a brigade. It has repair and replacement parts, assemblies, and components. System support teams from DS units may be sent forward to make on-site repairs when possible.

d. **Recovery.** Recovery is necessary to the repair of vehicles or other items essential to mission accomplishment, that cannot be repaired on site, or to prevent capture or destruction by the enemy. Except for the BFV, most damaged equipment can be carried by the platoon until the platoon sergeant coordinates its evacuation. When a BFV has to be recovered, the platoon leader reports its location and the type and extent of damage or, if known, the repair needed. As a minimum, the driver and gunner should remain with the BFV to secure it and to aid the recovery. The recovery vehicle with the MST supporting the company evacuates the damaged BFV to a logistics release point. There another recovery vehicle from the battalion maintenance platoon or the forward support battalion evacuates it to the unit maintenance collection point (UMCP). The maintenance support team's recovery vehicle could also evacuate to the UMCP.

2-45. PERSONNEL SERVICE SUPPORT

Primary platoon combat personnel service support functions include strength amounting, casualty reporting, replacement activities. The platoon leader and his noncommissioned officers are responsible for other PSS areas such as enemy prisoner of war (EPW) and the conduct of programs to counter the adverse impacts of stress and continuous operations. Working through company headquarters, platoon leaders also coordinate personnel service support provided by the battalion S1, personnel and administration center (PAC), and the unit ministry team. These agencies assist in such areas as awards and decorations; promotions; mail; and religious, legal, and pay support.

a. Proper accountability of platoon personnel and accurate strength reporting are essential to support decision-making by platoon leaders and company commanders and often the battalion commander. Using battle rosters, leaders in the platoon maintain accurate up-to-date records of their personnel. At periodic intervals they provide strength figures to the company CP. During combat they provide hasty strength reports on request or when significant changes in strength occur.

b. By-name casualty information is reported to company headquarters during lulls in the tactical situation. Soldiers having direct knowledge of an incident complete a DA Form 1155 (Witness Statement)

to report missing or captured soldiers (casualties no longer under US control). To report soldiers who are killed or wounded, they use DA Form 1156 (Casualty Feeder Report). After being collected and reviewed for accuracy by the platoon sergeant or platoon leader, these forms provide important casualty information. They are also used to determine the platoon's replacement requirements.

c. The manner in which a new soldier is welcomed into his platoon and integrated into its activities is key to his combat effectiveness, his survival, and his success on the battlefield. After being processed into the battalion by the PAC, the soldier is moved to the company. Upon arrival in the platoon, he should be met and welcomed by the platoon leader or platoon sergeant, or both. Once his name is logged onto the battle roster and he has been inspected and given a brief orientation to the platoon, he is quickly moved to the squad. In addition to similar squad-level in-processing, squad leaders pair the new soldier with an experienced soldier, who serves as his buddy.

d. EPWs and enemy documents and equipment are good sources of combat information. Soldiers must handle EPWs without violating international law. EPWs must be treated humanely; they must *not* be physically or mentally abused. The senior officer or NCO present is responsible for the care of EPWs. If a platoon cannot evacuate an EPW in a reasonable time, he must be given food, water, and first aid. He should not be given comfort items such as cigarettes and candy.

(1) Those EPWs who receive favors and those who become mistreated are poor interrogation subjects. In handling EPWs, soldiers use the five "S's":

(a) *Search* EPWs as soon as they are captured. Take their weapons and papers, except identification papers. Give a written receipt for any personal property and documents taken. Tag documents and personal property as to which EPW had them. Have one man guard while another searches. When searching, do not get between the EPW and the guard. To search a EPW, have him spread-eagle against a tree or wall, or on the ground in a push-up position with the knees on the ground. Search the EPW and all his gear and clothing.

(b) *Segregate* EPWs into the following categories: combatant (military) and noncombatant (civilians) male and female; officers and enlisted, civilians and deserters, nationality and ideology; and those who have surrendered (as opposed to those who resisted capture). Identifying prisoners may be difficult because of the

language barrier. Prisoners who cannot be readily identified will be segregated from other prisoners and treated as EPWs.

(c) *Silence* EPWs. Do not let them talk to each other. This keeps them from planning escape and from cautioning each other on security. Report anything an EPW says or tries to say to another EPW.

(d) *Speed* EPWs to the rear. Platoons turn EPWs over to the company where they are assembled and moved to the rear for questioning by qualified intelligence soldiers.

(e) *Safeguard* EPWs when taking them to the rear. Make sure they arrive safely. Watch out for escape attempts. Do not let them bunch up, spread too far out, or start diversions such as fist fights that create a chance for escape. At the same time, do not let anyone abuse them.

(2) If an EPW is wounded and cannot be evacuated through normal channels, he is treated by an aidman and evacuated through medical channels. The EPW must be guarded by other than medical soldiers.

(3) Before evacuating an EPW, he should be tagged with a captive and equipment/document tag (Figure 2-100, page 2-190) or a minimal tag (Figures 2-101 and 2-102, page 2-191). The tag should be perforated into three parts and made of durable material. It should measure about 10 centimeters by 10 centimeters for each part. It should be pierced at the top and bottom and reinforced for security for ease of attachment.

e. Enemy documents are a valuable source of information; they must be processed as quickly as possible. Documents can be official or personal. When a platoon captures documents in the custody of an EPW, the platoon leader or the senior leader at the capture site is responsible for preliminary screening and for reporting the capture of enemy documents to his next higher leader. That leader ensures that the documents are properly tagged and that the documents accompany the EPW to the point of turnover to the company.

f. Equipment and documents (operator's manuals, TMs, and so on) are a valuable source of information. They must be kept together and guarded throughout the capture and evacuation process to prevent looting, misuse, or destruction. Equipment and documents must be tagged. Captured enemy medical equipment and supplies are never used on US casualties but should be turned in for use on wounded EPWs.

<div style="border: 1px solid black; padding: 5px; margin-bottom: 5px;"> <p style="text-align: center;">ATTACH TO PW 123456</p> <hr/> <p>DATE OF CAPTURE A</p> <p>NAME : _____</p> <p>SERIAL NUMBER : _____</p> <p>RANK : _____</p> <p>DATE OF BIRTH : _____</p> <p>UNIT : _____</p> <p>LOCATION OF CAPTURE : _____</p> <p>CAPTURING UNIT : _____</p> <p>SPECIAL CIRCUMSTANCES OF CAPTURE : _____</p> <p>WEAPONS DOCUMENTS : _____</p> <hr/> <p>FORWARD TO UNIT 123456 B</p> <p>DATE OF CAPTURE : _____</p> <p>NAME : _____</p> <p>SERIAL NUMBER : _____</p> <p>RANK : _____</p> <p>DATE OF BIRTH : _____</p> <p>UNIT : _____</p> <p>LOCATION OF CAPTURE : _____</p> <p>CAPTURING UNIT : _____</p> <p>SPECIAL CIRCUMSTANCES OF CAPTURE : _____</p> <p>WEAPONS DOCUMENTS : _____</p> <hr/> <p>ATTACH TO ITEM 123456 C</p> <p>DATE OF CAPTURE : _____</p> <p>NAME : _____</p> <p>SERIAL NUMBER : _____</p> <p>RANK : _____</p> <p>DATE OF BIRTH : _____</p> <p>UNIT : _____</p> <p>LOCATION OF CAPTURE : _____</p> <p>DESCRIPTION OF WEAPONS DOCUMENTS : _____</p> <hr/> <p>DOCUMENT AND WEAPONS CARD</p> </div>	<div style="border: 1px solid black; padding: 5px; margin-bottom: 5px;"> <p style="text-align: center;">PW</p> <p style="text-align: center;">Do not remove this part from PW</p> <hr/> <p>Disarm and Search Thoroughly</p> <p>Tag Correctly</p> <p>Report Immediately</p> <p>Evacuate Rapidly</p> <p>Segregate by Category</p> <p>Safeguard from Danger, Escape</p> <p style="text-align: center;">PW</p> </div>
---	---

ONE-UP SERIAL NUMBER

NOTE

Main text to be printed in the national language.

On the back of the lower part should be written in red letters "ATTACH TO CAPTURED WEAPONS AND/OR DOCUMENTS."

Total tag should measure approximately 30 x 10 cm.

FRONT

Figure 2-100. EPW and document/equipment tag.

	DATE/TIME OF CAPTURE _____
	PLACE OF CAPTURE _____
●	CAPTURING UNIT _____
	CIRCUMSTANCES OF CAPTURE _____ (how it happened) _____

Figure 2-101. Minimal EPW tag.

	TYPE DOCUMENT/EQUIPMENT _____
	DATE/TIME CAPTURED _____
	PLACE OF CAPTURE _____ (grid coordinates) _____
●	CAPTURING UNIT _____
	CIRCUMSTANCES OF CAPTURE _____ (how it happened) _____
	PW FROM WHOM TAKEN _____

Figure 2-102. Minimal document/equipment tag.

2-46. HEALTH SERVICES SUPPORT

The platoon normally has an aidman from the battalion medical platoon. The aidman rides in the platoon sergeant's BFV when the platoon is mounted and with the infantry when dismounted. His job is to furnish emergency medical treatment, determine which casualties need to be evacuated, and prepare them for evacuation. He also advises the platoon leader on measures to help prevent sickness and injuries. These include measures to prevent exposure to heat and cold, food poisoning, and bad water. Because of limited medical resources, platoon and squad members must rely on self-aid and buddy-aid to ensure prompt and effective treatment to battlefield casualties. Additionally, command emphasis on combat lifesaver programs acts as a medical multiplier. At least one soldier in each squad and section must be trained as a combat lifesaver to help the aidman treat and evacuate casualties. The combat lifesavers are part of the platoon aid and litter team. Combat lifesavers provide initial treatment until medical personnel can treat the casualties, but only after their primary infantry duties are complete. They can also help in triage or treatment, or both, after medical personnel arrive, if the tactical and medical situation allow. The aidman informs the platoon

leader when there are casualties to be evacuated. Based on the tactical situation, the platoon leader decides when to evacuate casualties.

a. When the platoon is in contact, casualties awaiting evacuation should be protected from enemy fire until the fight is over.

b. The decision to evacuate casualties with serious wounds must be based on the effect of such action on mission accomplishment, and the possibility additional casualties might result. Casualties should never be deserted.

c. Weapons and NBC equipment of casualties to be evacuated are handled according to company SOP. **PERSONAL EFFECTS ON THE BODY OF A DEAD SOLDIER ARE NEVER REMOVED.** Any equipment or personal effects found after a soldier has been evacuated should be inventoried and sent to the company supply sergeant.

d. Casualties are either evacuated by the platoon or by the medical team supporting the company. This team is normally equipped with an armored ambulance.

(1) **Platoon evacuation.** The BFV is the quickest and safest way to evacuate casualties. The casualties are transported to the company casualty collection point. If a company casualty collection point has not been set up, or the situation does not permit use of a BN, the platoon leader requests help from the company commander. The platoon aidman goes with the casualties if they require immediate care. The aidman completes a DD Form 1380 (Field Medical Card) and attaches it to the casualty. This card stays with the casualty until evacuation is complete. The information on the card includes initial diagnosis and medication given.

(2) **Company evacuation.** When the company is to evacuate casualties, the casualties should be moved to a covered and concealed location to the rear of the platoon's position. This location must be reported to the company when the evacuation request is submitted. If enemy indirect fire presents a threat, the casualties are kept in a BFV and transferred to the ambulance when it arrives. When this is done, the platoon leader may send two men or a fire team to secure the location and guide the ambulance.

Section IX

BRADLEY FIGHTING VEHICLE AND TANK OPERATIONS

Armored and mechanized forces normally work together in combat operations. This section discusses tactics and techniques used by mechanized infantry platoons working with armor. A company team consists of mechanized infantry platoons and tank platoons. Each platoon has unique characteristics and should be employed to complement the others and be prepared to provide mutual support. A BFV platoon can take advantage of the tanks' firepower, armor protection, and mobility in the offense; and the tanks' laser ranger finder to move into positions in the defense. Tanks can take advantage of the BFV platoon's ability to provide close-in protection from dismounted attacks in the defense.

2-47. MOVEMENT WITH TANKS

When terrain, visibility, and the enemy situation permit mounted movement, tanks normally lead followed or overmatched by BFVs.

a. **Tanks in the Lead.** Tanks normally lead a movement formation because of their survivability, firepower, and shock effect. The BFV platoon normally moves 200 to 400 meters behind the tanks in order to support them and at the same time avoid fires directed at the tanks (Figure 2-103, page 2-194).

(1) When the company team uses traveling or traveling overwatch movement techniques, the commander stipulates the sequence and locations for movement and the distance between the tanks and BFVs. BFVs must be close enough to protect the flanks and rear of the tanks.

(2) When the company team uses bounding overwatch, a tank platoon usually serves as the bounding element successively overmatched by BFVs and, in some cases, by other tanks. Because tank crews have difficulty seeing behind them, one of the BFV platoon's primary jobs is to protect the tanks' rear and flanks from enemy infantry attack. The platoon must be alert for enemy antiarmor positions. Since ATGM fires are usually characterized by a trail of smoke from the launch site, the BFV commanders should suppress the enemy antiarmor weapon and send a warning over the radio.

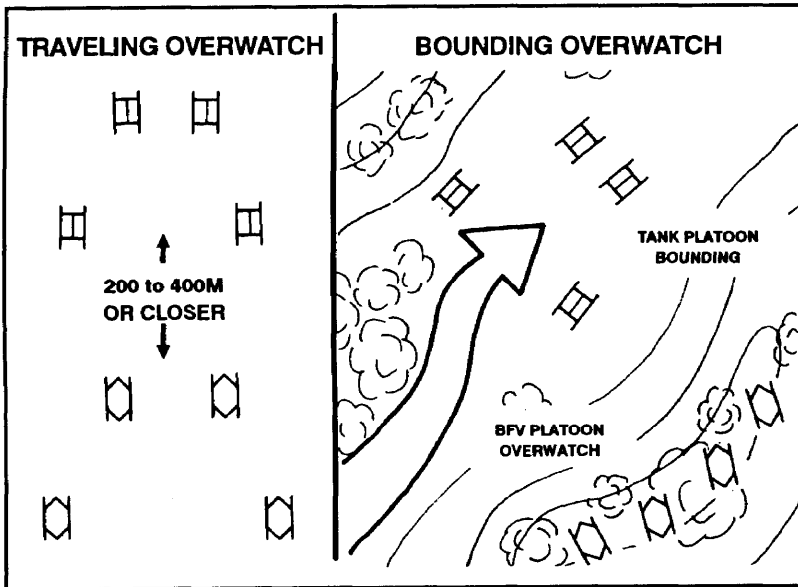

Figure 2-103. Tanks leading.

b. **Dismounted Element Leading Tanks.** The mounted platoon seldom leads tanks. Usually, the dismounted element of the platoon leads to breach obstacles, to move through restrictive terrain, to clear defiles, or to act as a guide when visibility is limited (Figure 2-104).

(1) When an obstacle hinders mounted movement, the dismount element clears or breaches it, or finds a bypass. It approaches the obstacle using bounding overwatch, while BFVs are positioned to support. Also, when visibility interferes with mounted movement, the dismount element leads, overmatched by the BFVs and tanks.

(2) Fire control is difficult while moving during limited visibility, but it is facilitated by using the wingman concept. It can be done only if the platoon has practiced the SOP. Indirect-fire illumination should not be relied on, because it is slow and not as effective in smoke, fog, snow, dust, or heavy rain. Additionally, heavy rain or cold fog reduces thermal sight range capability. Although the thermal sight allows the BFV and tanks to acquire a target at great distances during reduced visibility, it does not provide a clear 'enough sight picture for vehicle identification. Platoons using thermal sights for long distances must establish positive identification and check-fire procedures to preclude destroying friendly vehicles or personnel.

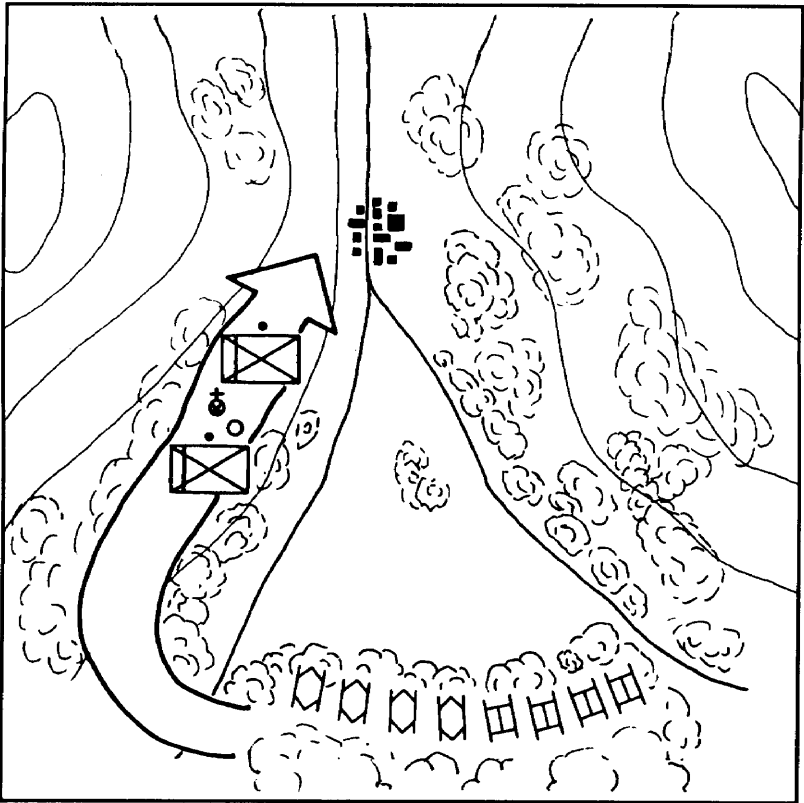

Figure 2-104. Dismounted element leading tanks.

2-48. COMMUNICATION WITH TANKS

Before an operation, mechanized infantry and tank leaders must coordinate communications means and signals. This includes the use of radios, phones, and visual signals (such as arm-and-hand, panel, lights, flags, and pyrotechnics). The BFV's communication system provides for control of mounted and dismounted operations. Tanks have the same system.

a. **BFVs Communicating With Tanks.** As communication systems are updated, platoons will have the single-channel ground/airborne radio system (SINCGARS). This allows secure communication between tanks, BFVs and the dismounted element. During defensive operations, tanks and BFVs can communicate by running communication wire between vehicles.

b. **Dismounted Infantry Communicating With Tanks.** Most tanks, with the exception of the M1, have an external phone on the rear fender for dismounted infantrymen to use. On the M1, the infantryman can run communication wire to the tank crew through the turret. This wire is hooked into the tank's communication system. Leaders must be confident that tanks and dismounted infantry can move and shoot without the risk of fratricide and confusion.

Section X OBSTACLES

An obstacle is any natural or man-made obstruction that turns, fixes, disrupts, or blocks the movement of a force. The platoon must know how to employ obstacles and how to breach and clear obstacles. (See FM 5-34 and FM 5-102 for additional information concerning obstacles.)

2-49. EMPLOYMENT OF OBSTACLES

Obstacles are used in all operations, but are most useful in the defense. Engineers normally construct obstacles with help from the platoon. There will be times when the platoon must build obstacles without engineer help. In such cases, the leader should seek engineer advice on the technical aspects. Platoon leaders must always consider what materials are needed and how long the obstacle will take to construct.

In the offense, the platoon uses obstacles to—

- Aid in flank security.
- Limit enemy counterattack.
- Isolate objectives.
- Cut off enemy reinforcement or routes of withdrawal.

In the defense, the platoon uses obstacles to—

- Slow the enemy's advance to give the platoon more time to mass fires on him.
- Protect defending squads and sections.
- Canalize the enemy into places where he can more easily be engaged.
- Separate the enemy's tanks from his infantry.
- Strengthen areas that are lightly defended.

a. **Functions.** Obstacles perform one of four tactical functions—disrupt, turn, fix, or block.

(1) **Disrupt.** These obstacles are used to disrupt assault formations, attacking the low-level command and control while the attacker is under direct fire.

(2) **Turn.** Turning obstacles move and manipulate the enemy to the force's advantage by enticing or forcing him to move in a desired direction, by splitting his formation, by canalizing him, or by exposing his flank.

(3) **Fix.** Fixing obstacles slow and hold the enemy in a specific area so that he can be killed with fires, or the obstacles generate the time necessary for the force to break contact and disengage.

(4) **Block.** Blocking obstacles are complex, employed in depth, and integrated with fires to prevent the enemy from proceeding along a certain avenue of approach. Blocking obstacles serve as a limit, beyond which the enemy will not be allowed to go.

b. **Principles of Employment.** When employing obstacles, the leader considers the following principles.

(1) **Support the tactical plan.** Obstacles supplement combat power, decrease the mobility of the enemy, and provide security for the platoon. While considering enemy avenues of approach, the leader also considers his own movement requirements such as routes for resupply, withdrawal, counterattacks, patrols, and observation posts.

(2) **Tie in.** He ties in his reinforcing obstacles with existing and natural obstacles. He must also coordinate the obstacle plan with his plans for fire support.

(3) **Covered by observation and fire.** He ensures that all obstacles are covered by observation and fire. This reduces the enemy's ability to remove or breach the obstacles and increases the possibilities of placing fire on the enemy when he encounters the obstacles.

(4) **Constructed in depth.** He emplaces obstacles so that each new obstacle encountered by the enemy attrites the enemy force and causes a desired and controlled reaction. Proper use of obstacles in depth weakens the enemy and significantly increases the overall desired effect.

(5) **Employed for surprise.** An obvious pattern of obstacles would disclose locations of platoons and weapons. Friendly forces must avoid readily visible patterns.

2-50. TYPES OF OBSTACLES

The two types of obstacles are existing and reinforcing.

a. **Existing Obstacles.** Existing obstacles are those natural or cultural restrictions to movement that are part of the terrain when battle

planning begins. The location and characteristics of natural or cultural obstacles have a direct relationship to the plan of operations and the positioning of forces. Existing obstacles should be easily converted into more effective obstacles, they should be in defilade from enemy observation, they should be where friendly observation and fires can prevent enemy breaching, and they should be difficult to bypass. Existing obstacles include the following.

(1) **Steep slopes.** Varying degrees of incline are required to stop different types of vehicles. Tanks can negotiate slopes as steep as 60 percent. Craters, mines, abatis, and induced landslides increase the obstacle value of slopes.

(2) **Escarments.** Vertical (or near-vertical) cuts and walls over 1 ½ meters high cannot be crossed by vehicles without some type of breach. Thick rock walls, railroad embankments, and steep fills along highways are examples of escarpments.

(3) **Ravines, gullies, and ditches.** Ravines, gullies, and ditches are obstacles to wheeled vehicles. If over 5 meters wide, these obstacles are usually effective against tracked vehicles.

(4) **Rivers, streams, and canals.** The major obstacle value of rivers, streams, and canals is that they must be crossed by special means: deepwater fording or surface or aerial means. The ease of crossing by deepwater fording and surface means is determined by the width and depth of the water obstacle, the water velocity, and the condition of the banks and bottom.

(5) **Swamps and marshes.** Swamps and marshes, where firm ground is lacking or is a meter or so below water level, are effective obstacles against all types of vehicles. They also severely restrict the mobility of infantry.

(6) **Snow.** Even on otherwise trafficable terrain, snow 1 meter deep becomes a major obstacle to personnel and vehicles.

(7) **Trees.** Heavy stands of trees that are 8 inches or more in diameter, spaced less than 20 feet apart, will eventually build up into an obstacle if tracked vehicles attempt to push them over and force their way through.

(8) **Built-up area.** The obstacle value of a built-up area depends on its size, location, and construction. The natural obstacle value of built-up areas can be increased by cratering streets; demolishing walls; overturning or derailling street or railroad cars; and constructing roadblocks from steel rails, beams, and rubble. When reinforced with mines and barbed wire, such obstacles protect against armored, mechanized, and infantry forces.

b. Reinforcing Obstacles. Reinforcing obstacles are those specifically constructed, emplaced, or detonated to tie together, strengthen, and extend existing obstacles. Careful evaluation of the terrain, to determine its existing obstructing or canalizing effect, is required to achieve maximum use of reinforcing obstacles. Installation time and manpower are usually the two most important factors. Infantry platoons provide the most readily available source of manpower. Reinforcing obstacles include the following.

(1) **Road craters.** Road craters are effective obstacles on roads or trails if the areas on the flanks of the crater are tied into steep slopes or mined areas.

(2) **Abatis.** An abatis is an obstacle created by cutting down trees so that their tops are crisscrossed and pointing toward the expected enemy direction. It is most effective for stopping vehicles in a forest. This obstacle may be reinforced with mines and booby traps.

(3) **Ditches.** Ditches across roads and trails are effective obstacles. Large ditches in open areas require engineer equipment.

(4) **Log hurdles.** Log hurdles act as “speed bumps” on roads. They are easily installed and are most effective when used in conjunction with other obstacles.

(5) **Log cribs.** A log crib is constructed of logs, dirt, and rocks. The logs are used to make rectangular or triangular cribs that are filled with dirt and rock. These are used to block narrow roads and defiles. Log cribs must be solidly built to stop tanks.

(6) **Log posts.** Log posts embedded in the road and employed in depth can effectively stop tracked vehicles. If they are not high enough to be pushed out of the way, posts can cause a tracked vehicle to throw a track if it tries to climb over. If employed with wire and mines, they can also slow infantry.

(7) **Rubble.** Rubble from selected masonry structures and buildings in a built-up area will limit movement through an area and provide fortified fighting positions.

(8) **Wire entanglements.** Wire entanglements impede the movement of infantry and, in some cases, tracked and wheeled vehicles. The materials used in constructing wire entanglements are relatively lightweight (compared to other obstacles) and inexpensive, considering the protection they afford.

(a) **Triple standard concertina fence.** The most common wire entanglement a platoon or squad may build is the triple standard concertina fence. (Figure 2-105, page 2-200.) It is built of either barbed wire concertina or barbed tape concertina. There is no difference in

building methods. The material and labor requirements for a 300-meter triple standard concertina fence are—

- Long pickets—160
- Short pickets—4
- Barbed wire, 400-meter reels—3
- Rolls of concertina—59
- Staples—317
- Man-hours to erect—30

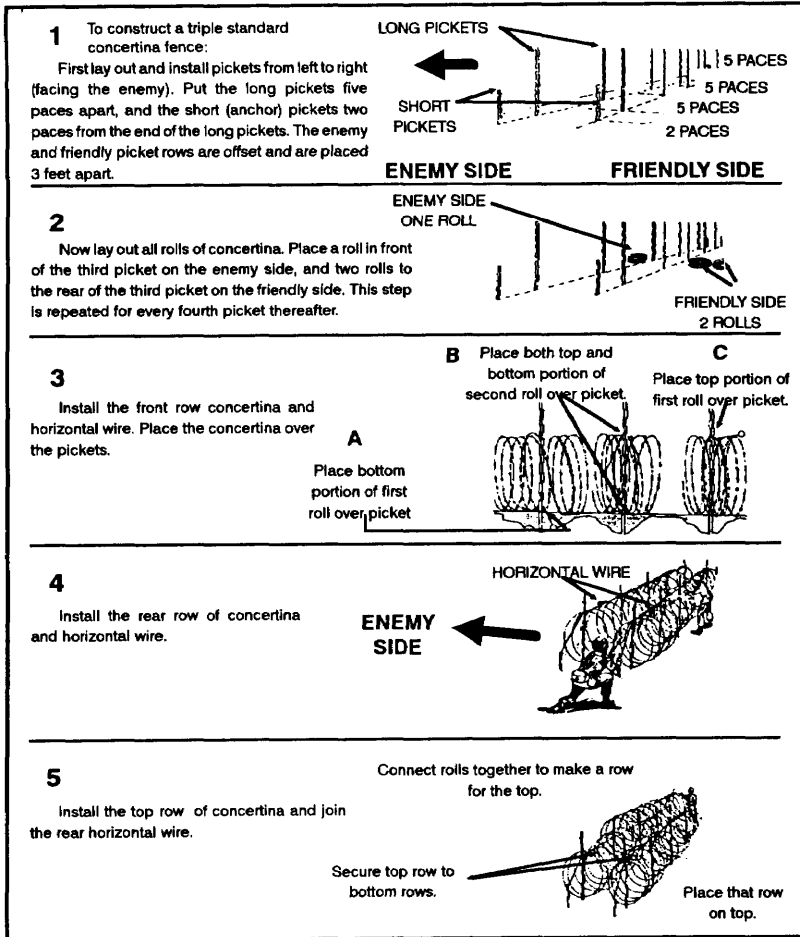
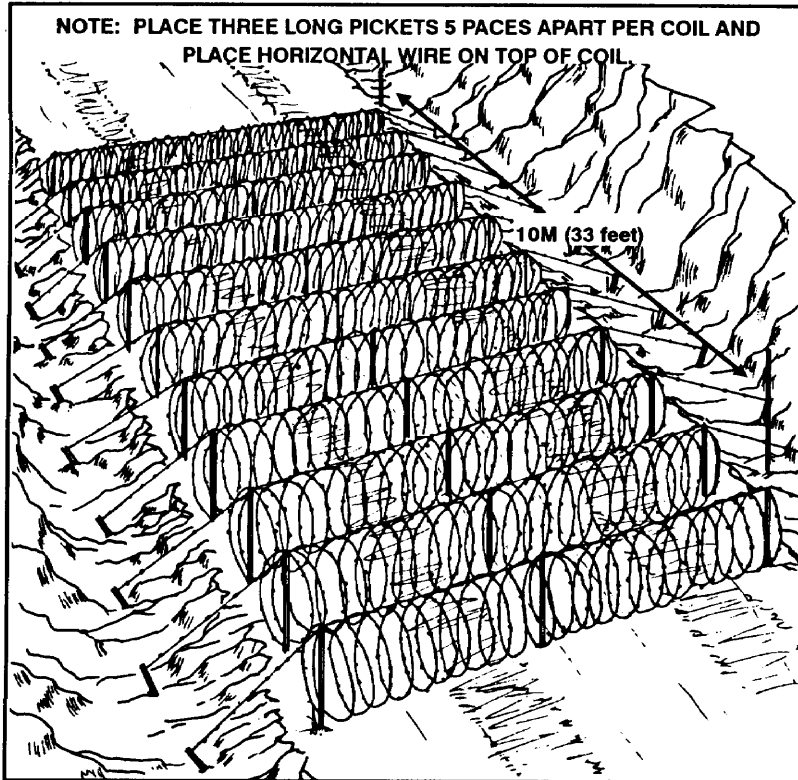

Figure 2-105. Concertina fence.

(b) *Concertina roadblock*. The concertina roadblock is placed across roadways and designed to block wheeled or tracked vehicles. The roadblock is constructed of 11 concertina rolls or coils placed together, about 10 meters in depth, reinforced with long pickets five paces apart. The rolls or coils should not be tautly bound, thus allowing them to be dragged and tangled around axles, or tank road wheels and sprockets. Additionally, wire is placed horizontally on top of the concertina rolls or coils. (See Figure 2-106.)



Figures 2-106. Concertina roadblock.

(c) *Tanglefoot*. Tanglefoot is used to provide concealment where needed and to prevent the enemy from crawling between fences and in front of emplacements. The obstacle should be employed in a minimum width of 32 feet. The pickets should be placed at irregular intervals

of 2 ½ feet to 10 feet, and the height of the barbed wire should vary between 9 to 30 inches. Tanglefoot should be sited in scrub, if possible, using bushes as supports for part of the wire. On open ground, short pickets should be used.

(9) **Mines.** Mines are one of the most effective tank and personnel killers on the battlefield. Minefields that an infantry platoon or squad most commonly emplace are the hasty protective, point, and phony.

(a) **Hasty protective minefield.** In the defense, platoons and BFV squads lay hasty protective minefields to supplement weapons, prevent surprise, and give early warning of enemy advance. A platoon can install hasty protective minefields, but only with permission from the company commander and only if he has authority from higher headquarters.

- Three reports are also required—intention, initiation, and completion. Hasty protective minefields are reported to the company commander and recorded on DA Form 1355-1-R. The leader puts the minefield across likely avenues of approach, within range of and covered by his organic weapons and some indirect fire weapons. If time permits, the mines should be buried to increase effectiveness, but they may be laid on top of the ground in a random pattern. The BFV platoon's basic load of mines consists of two per vehicle. Additional mines can be requested through the supply system and delivered by LOGPAC.
- The minefield should be recorded before the mines are armed. The leader installing the minefield should warn adjacent platoons and tell the company commander of the minefield's location. When the platoon leaves the area (except when forced to withdraw by the enemy), it must remove the minefield or transfer the responsibility for the minefield to the relieving platoon leader. Only metallic mines are used in hasty protective minefields. Booby traps are not used in hasty protective minefields; they delay removal of the mines. The employing platoon must make sure that the minefield can be kept under observation and covered by fire at all times. The following example describes how to lay a hasty protective minefield.

EXAMPLE

After requesting and receiving permission to lay the minefield, the platoon leader and BFV squad leaders reconnoiter to determine exactly where to place the mines. The leaders find a need to use antitank mines

to block enemy vehicles at the bridge and the ford. The leaders decide that antipersonnel mines are needed to protect the antitank mines and to cover the likely avenues of approach of enemy infantry (Figure 2-107).

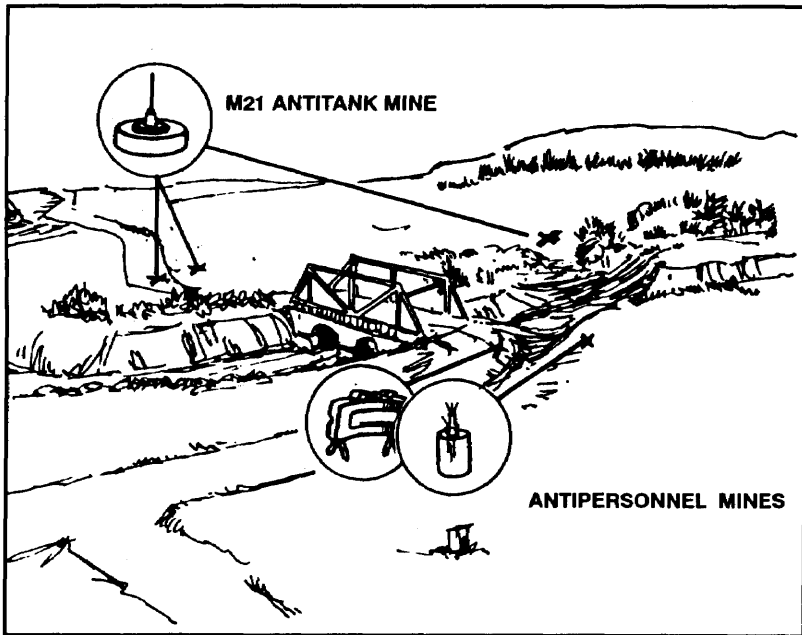

Figure 2-107. Antipersonnel and antitank mines in a hasty protective minefield.

While the soldiers are placing the mines, the platoon leader finds an easily identifiable reference point in front of the platoon's position, but well behind the minefield. The platoon leader records the minefield using a reference point (in this example, the concrete post) (Figure 2-108, page 2-204). The row of mines closest to the enemy is designated A and the succeeding rows are B, C, and so on.

The ends of a row are shown by two markers. They are labeled with the letter of the row and number 1 for the right end of the row and number 2 for the left end of the row, facing the enemy. The rows are numbered from right to left. The marker can be a steel picket or wooden stake with a nail or a can attached so that it can be found with a metallic mine detector.

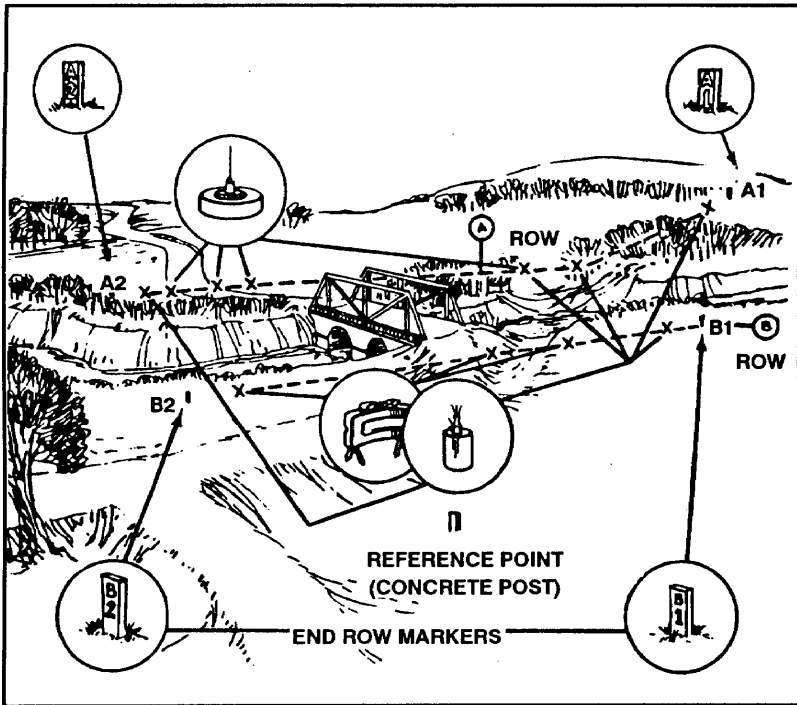

Figure 2-108. Leader visualizes hasty protective minefield.

After determining the rows, the platoon leader places a row marker 15 to 25 paces to the right (outside) of the first mine. In this case, the row marker is B. From the concrete post, the platoon leader measures the magnetic azimuth in degrees and paces the distance to row marker B-1. (Figure 2-109.) The platoon leader places a marker at B-1 and records the azimuth and distance from the concrete post to B-1 on DA Form 1355-1-R.

Row A marker is placed in the same manner as row B. Next, from B-1 the platoon leader measures the azimuth and distance to A-1. The platoon leader then measures the distance and azimuth from A-1 to the first mine in row A and records the location of the mine. He then measures the distance and azimuth from the mine to the secondhand so on until all mine locations have been recorded as shown. The platoon leader gives each mine a number to identify it in the tabular block of DA Form 1355-1-R. When the last mine location in row A is recorded, the platoon leader

measures an azimuth and distance from the last mine to another arbitrary point between 15 and 25 paces beyond the last mine. He places a marker here and calls it A-2. The platoon leader follows the same procedure with row B.

When the platoon leader finishes recording and marking the rows, he measures the distance and azimuth from the reference point to B-2, and from B-2 to A-2, and records them.

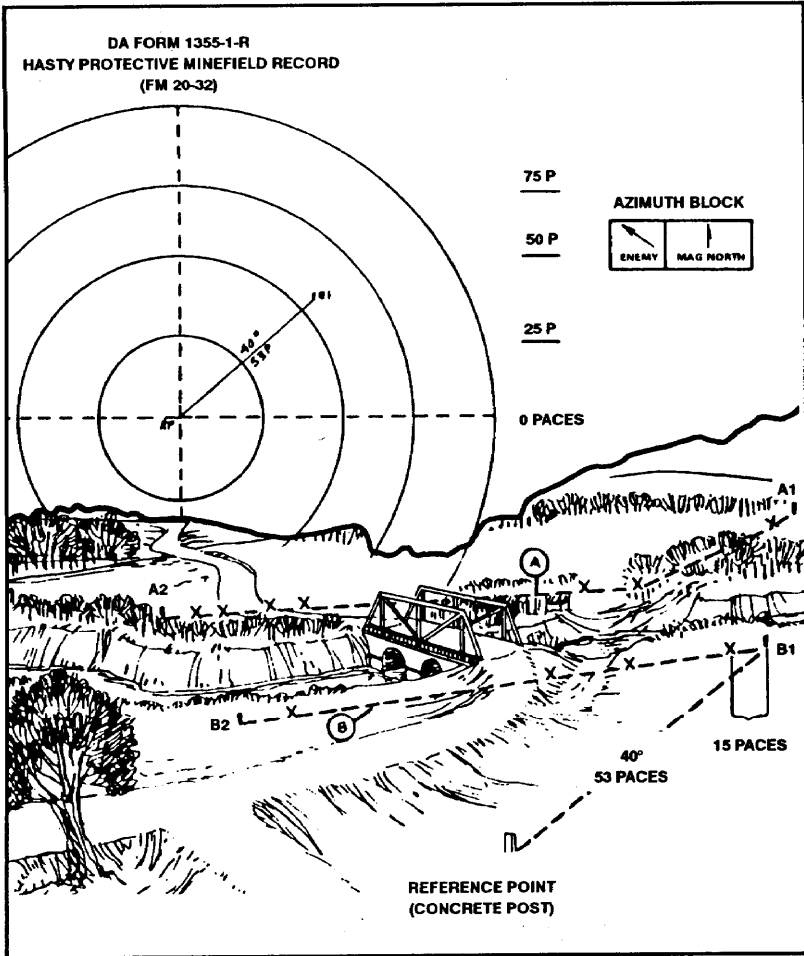

Figure 2-109. Marking and recording minefield.

The platoon leader now ties in the reference point with a permanent landmark that he found on the map. He measures the distance and the azimuth from this landmark to the reference point. He may use the landmark to help others locate the minefield should it be abandoned. Finally, he completes the tabular and identification blocks.

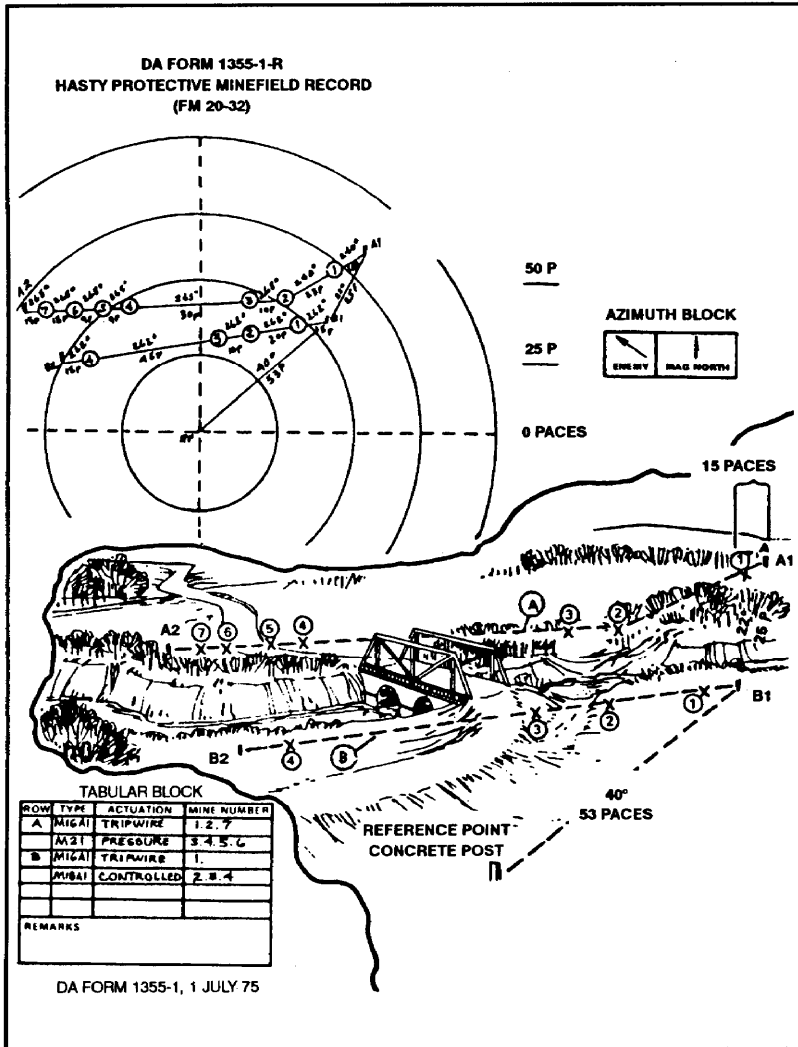

Figure 2-109. Marking and recording minefield (continued).

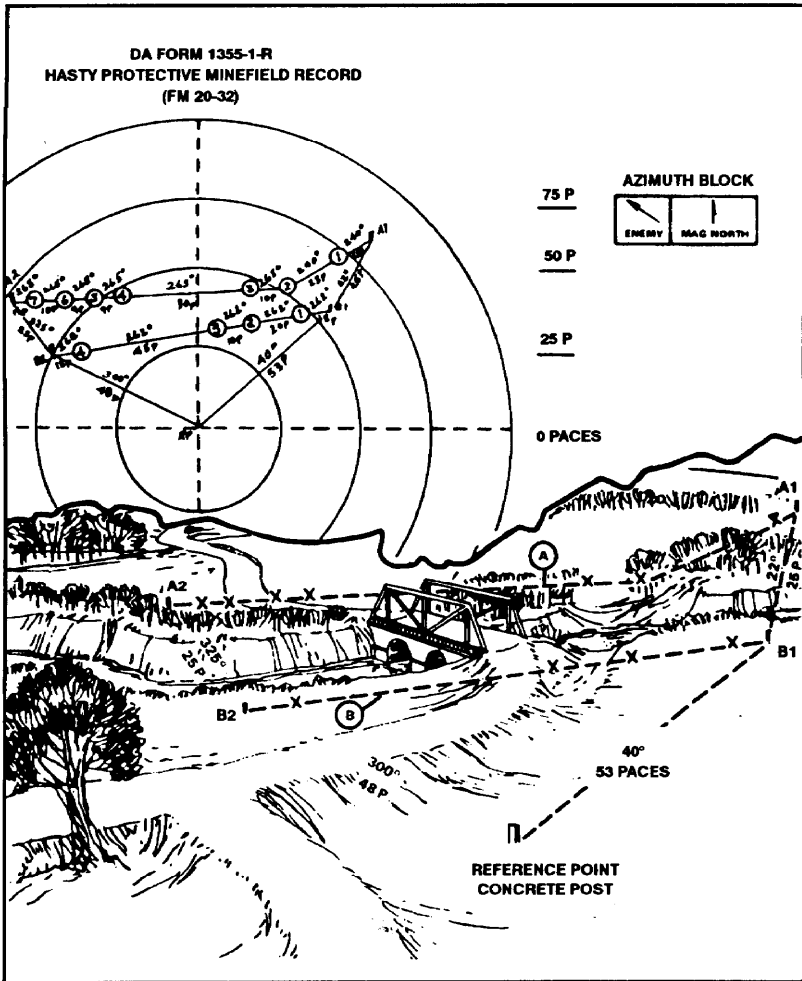
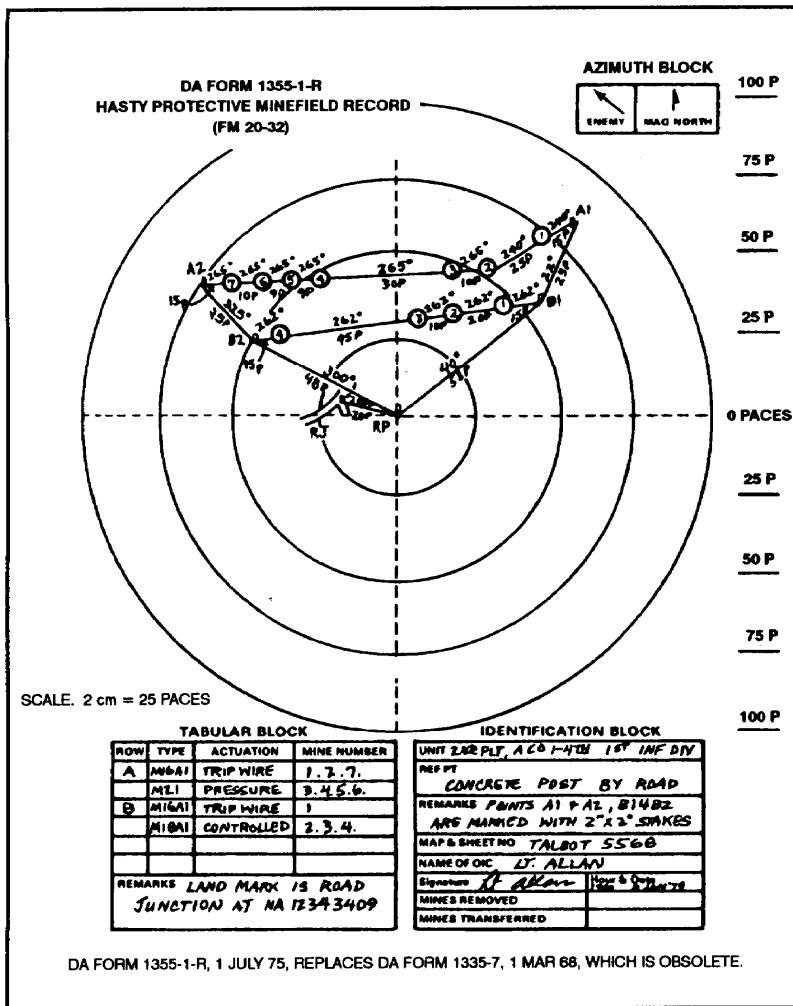

Figure 2-109. Marking and recording minefield (continued).

While the platoon leader is tying in the landmark, the soldiers arm the mines nearest the enemy first (row A). The platoon leader reports that the minefield is completed and keeps DA Form 1355-1-R. If the minefield is transferred to another platoon, the gaining platoon leader signs and dates the mines transferred block and accepts the form from the previous leader. When the minefield is removed, the form is destroyed. If the minefield is left unattended or abandoned unexpectedly, the form

must be forwarded to the company commander. The company commander forwards it to battalion to be transferred to more permanent records.



DA FORM 1355-1-R, 1 JULY 75, REPLACES DA FORM 1335-7, 1 MAR 68, WHICH IS OBSOLETE.

Figure 109. Marking and recording minefield (continued).

When retrieving the mines, the soldiers start at the reference point and move to B-1, using the azimuth and distances as recorded. They then move from B-1 to the first mine in row B. However, if B- 1 is destroyed,

they move from the reference point to B-2 using that azimuth and distance. They will now have to shoot the back azimuth from B-2 to the last mine. The stakes at A-1, B-1, A-2, and B-2 are necessary, because it is safer to find a stake when traversing long distances than to find a live mine.

(b) *Point minefields*. Point minefields disorganize enemy forces and hinder their use of key areas. Point minefields are of irregular size and shape, and include all types of antitank and antipersonnel mines, and antihandling devices. They should be used to add to the effect of existing and reinforcing obstacles, or to rapidly block an enemy counterattack along a flank avenue of approach.

(c) *Phony minefields*. Phony minefields, used to degrade enemy mobility and preserve friendly mobility, simulate live minefields and deceive the enemy. They are used when lack of time, personnel, or material prevents use of actual mines. Phony minefields may be used as gaps in live minefields. To be effective, a phony minefield must look like a live minefield by either burying metallic objects or making the ground look as though objects are buried.

2-51. ENEMY OBSTACLES

Platoons bypass and breach enemy obstacles. The decision to bypass or breach is based on the mission, the situation, and the assets available.

a. **Bypassing**. Obstacles are bypassed if at all possible. When bypassing an obstacle, the leader reports its type and location to higher headquarters. The leader must be alert for enemy contact when bypassing, because the enemy normally covers the bypass routes by fire.

b. **Breaching**. A breach is the employment of any means available to break through or secure a passage through an enemy obstacle. In accordance with FM 90-13-1, the four types of breaches are in-stride, deliberate, assault, and covert.

(1) **In-stride breach**. The in-stride breach involves the breach of an obstacle or obstacles to maintain the momentum of an attack by attempting to breach them as they are encountered.

(2) **Deliberate breach**. A deliberate breach is conducted when it is not possible or necessary to cross an obstacle in stride, or after a hasty breach has failed. It is characterized by detailed planning and preparation, and executed with engineer assistance.

(3) **Assault breach**. The assault breach is conducted by company teams and platoons assigned the mission of assaulting an objective as part

of a larger force's attack. The assault breach allows a force to penetrate an enemy's protective obstacles and destroy the defender in detail.

(4) **Covert breach.** The covert breach is a special breaching operation used by dismounted forces during limited visibility. It is silently executed to achieve surprise and to minimize casualties. The covert breach relies on stealth, quiet manual lane-reduction techniques, and dismounted maneuver. A covert breach is used during an assault when the need for surprise outweighs the need for overwhelming suppression.

2-52. BREACHING AND CLEARING OF OBSTACLES

Leaders must know the techniques used to overcome reinforced obstacles. Obstacles can restrict vehicular movement. The platoon may have to clear obstacles to help vehicles go forward. The platoon may not be able to keep the enemy from knowing that it is going to breach, but it may keep the enemy from knowing where and when it will breach. The platoon breaches different obstacles using different techniques, types of equipment, and explosives or MICLIC if available. Equipment and explosives may include rocket-propelled line charges, mine detectors, bangalore torpedoes, grappling hooks, direct fire weapons, and hand-emplaced explosives. Platoons breach all obstacles using the same fundamentals (SOSR):

- Suppress the enemy to allow the breach element to create a breach.
- Obscure the breach site from enemy observation.
- Secure the breach site, execute the breach, and secure the far side.
- Reduce the obstacle to facilitate movement of follow-on forces.

a. **Minefields.** The objective of a minefield breach is to clear a path or lane through a mined area for friendly forces to continue their mission. The selection of lane locations should take advantage of cover and concealment, overmatching fires, and the commander's scheme of maneuver. Breaching a minefield where it is first encountered before considering other possible sites is not recommended.

DANGER
CHEMICAL MINES ARE NOT BLOWN IN PLACE.

(1) **Step 1. Suppress the Enemy.** The enemy covering the obstacle must be suppressed.

(2) **Step 2. Obscure with Smoke.** Smoke is used to obscure the obstacle area and conceal friendly soldiers.

(3) **Step 3. Probe and Mark Mines.** A footpath or lane is probed and the mines are marked. The preferred way to clear a lane through a minefield is to use a rocket-propelled line charge or bangalore torpedo. (Figure 2-110.) The only way to clear a minefield without special equipment is to probe with a pointed nonmetallic object. One squad probes while the platoon (-) overmatches. (Figure 2-111.)

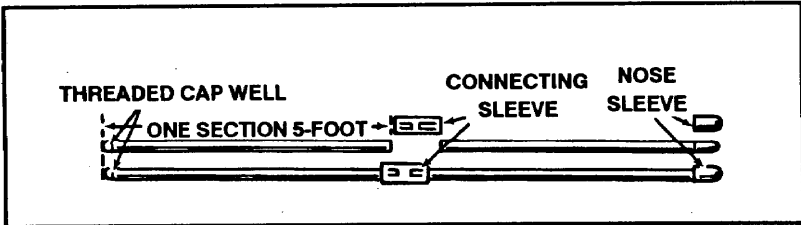

Figure 2-110. Bangalore torpedo.

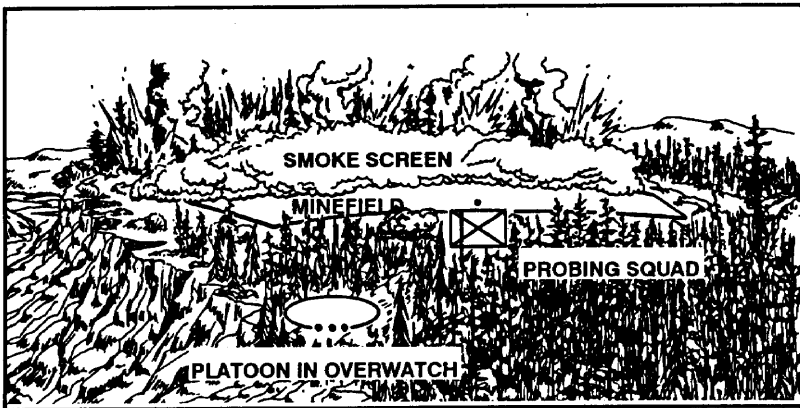

Figure 2-111. Platoon (-) overwatches probing squad.

(a) The squad probing the footpath or lane through the minefield uses two probers—one in front, clearing a lane wide enough to crawl through, and one prober clearing 10 meters behind and slightly to one side so that their lanes overlap.

(b) Two other soldiers crawl behind to secure the probers, to carry additional supplies, or to take a prober's job if one becomes a casualty.

The probers should be rotated often to keep them from getting tired or careless, or both. (Figure 2-112.)

(c) The probers wear their protective vests and helmets, and carry their NBC masks. They roll up their sleeves and remove rings and watches. LBE, rucksacks, weapons, and other metallic equipment are carried by other members of the breach force.

DANGER
WHEN INTELLIGENCE INDICATES THE PROBABILITY OF
MAGNETICALLY INFLUENCED FUZES, SOLDIERS MUST
NOT WEAR METALLIC ITEMS.

NOTE: If in a contaminated environment, probers must maintain protective posture.

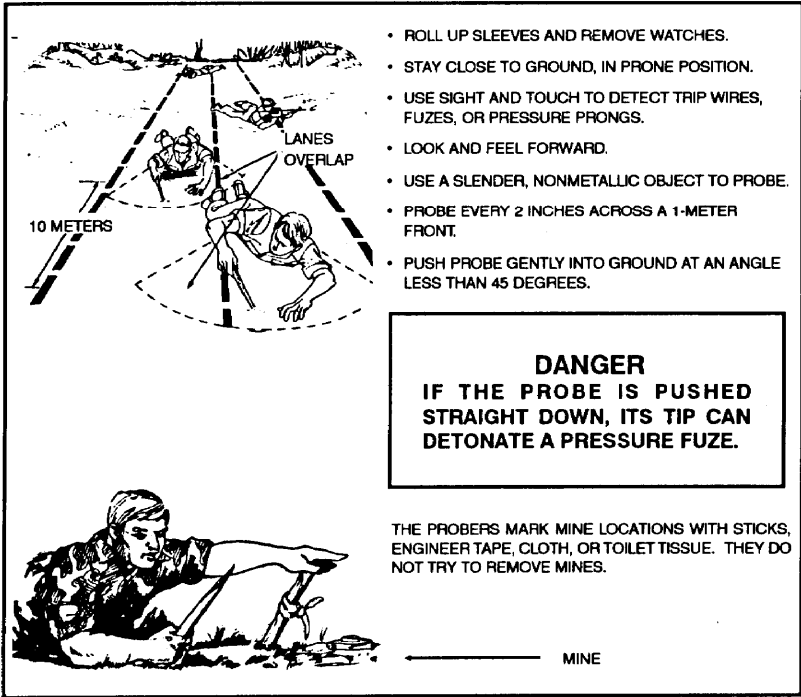

Figure 2-112. Probing for mines.

(d) If the probe meets resistance and does not go into the ground freely, the prober picks the soil away with the tip of the probe and removes the loose dirt by hand. If it is a mine, they remove enough soil to see what type of mine it is. They mark its location without attempting to remove or disarm the mine.

NOTE: If a soldier is injured in a minefield, all other soldiers freeze. The nearest soldier probes his way to the injured soldier, applies first aid, and carries him out-carefully moving back through the probed lane.

(4) **Step 4. Secure the Far Side.** As soon as the breaching element has probed a lane, it or another element secures the far side. Dismounted forces should secure the far side of an obstacle as quickly as possible. This helps keep the enemy from attacking or placing fires on the breach site. When breaching an obstacle for vehicles, if the dismounted element can bypass on foot, leaders should designate an element to bypass the obstacle and secure the far side while the breaching effort is on-going. That element should have machine guns; light and or medium antiarmor weapons; and a map, compass, and binoculars or thermal sight to call for and adjust fires.

(5) **Step 5. Reduce the obstacles.** Marked mines are destroyed with explosives or grappling hooks. Metallic mines must be destroyed before moving soldiers through the lane.

(6) **Step 6. Mark Cleared Lane.** The breach element marks the cleared lane.

(7) **Step 7. Move Unit Through the Obstacle.** The leader moves the platoon through the obstacle.

b. Tank Ditches. SOSR is applied in breaching tank ditches (Figure 2-113, page 2-14). Mechanized infantry can reduce tank ditches by bringing down the sides of the ditch with D-handled shovels, helmets, or explosives. An armored combat earthmover, tank with blades, or combat engineer vehicle should be used to reduce the obstacle quickly.

c. Craters. SOSR is applied. A crater is reduced using the same steps as a tank ditch.

d. Wire. SOSR is applied. If vehicles are available, they should be used to pull wire entanglements off assault paths, detonating antipersonnel mines in the process. Another method is for soldiers to prepare and emplace material over the wire to make an assault footpath. The assaulting force must first clear the wire of antipersonnel mines before laying material onto the wire. Another method is to cut through the wire obstacle as described below, after suppressing the enemy and obscuring their visibility. The clearing squad uses wire cutters, bangalore torpedoes, or explosives to remove the wire. The clearing squad checks

for and marks mines and booby traps. One squad breaches while the platoon (-) overmatches. Tank fire, combat engineer vehicle fire, and massed indirect and direct fire can help breach the wire, if available. As soon as the breach element has cleared a lane, it secures the far side. Marked mines are destroyed with explosives or grappling hooks. Then, the cleared lane is marked.

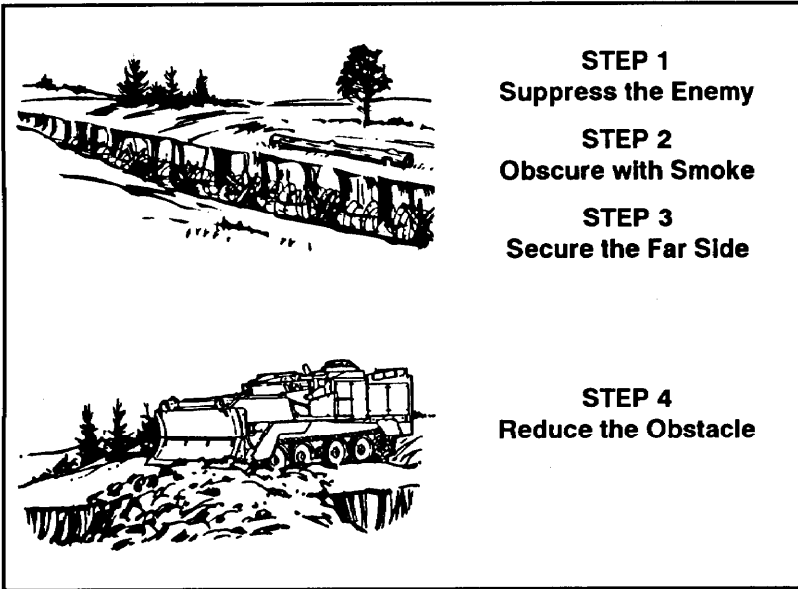

Figure 2-113. Clearing a tank ditch.

Section XI

NUCLEAR, BIOLOGICAL, AND CHEMICAL OPERATIONS

The mechanized infantry platoon must be able to fight on the nuclear, biological, and chemically contaminated battlefield. The three fundamentals of NBC operations are contamination avoidance, protection, and decontamination. An understanding of these fundamentals enhances operational readiness and survival on the integrated battlefield.

2-53. OPERATIONS IN A NUCLEAR ENVIRONMENT

The platoon's ability to fight in a nuclear environment, as in any combat situation, depends largely on how well individual and collective tasks have been learned in training. During training and operations, the proper positioning and movement of soldiers and vehicles and the proper construction of fighting positions with overhead protection must be stressed. When the platoon can do all the individual and collective tasks while employing nuclear protective measures, its chances of continuing to be combat effective on the integrated battlefield are improved.

a. **Nuclear Weapons Effects.** Nuclear weapons produce four primary effects: blast, thermal radiation (heat and light), nuclear radiation, and electromagnetic pulse. The degree of nuclear effect depends on how close a platoon is to the detonation and how well soldiers and equipment are protected.

(1) **Blast.** When a nuclear weapon detonates, it sends out a shock wave at the speed of sound in all directions. It can collapse buildings and hurl men and equipment. The blast effect has two phases: the positive phase or shockwave, and the negative phase or suction effect.

(2) **Thermal radiation.** Thermal radiation produced by a nuclear explosion consists of intense heat and extremely bright light. Unprotected soldiers exposed to this heat and intense light can be severely burned and blinded. Materials (such as wood, plastics, and rubber) may melt or burn. The extent of these effects depends on the kind of weapon, weather, and terrain. Fog or heavy battlefield smoke can reduce the effects of thermal radiation. On clear nights, the blinding effect is greater, and night vision devices can be damaged.

(3) **Nuclear radiation.** A nuclear weapon produces two forms of nuclear radiation—initial and residual. Both forms of radiation can injure or kill. The human body can survive limited exposure to radiation, but

the effects add up; each dose a person receives adds to earlier doses. Hoop exposure to radiation must be measured and recorded so the amount of radiation absorbed can be monitored. Soldiers should be taken out of contaminated areas before they are exposed to an overdose of radiation.

(a) Initial radiation occurs during the first instant of the explosion. Since this radiation travels at the speed of light, the only way to lessen the danger is to be protected before the detonation.

(b) Residual radiation remains after the first minute. It is caused by materials being exposed to the initial radiation and retaining the radiation effects. It is found around the site of the nuclear detonation. If radioactive particles are carried aloft, they become fallout, which may spread over a larger area. Fallout is created by dust sucked into the explosion and later scattered by the wind. Such things as dirt, equipment, and buildings become contaminated from exposure to either initial radiation or fallout.

(4) **Electromagnetic pulse.** EMP is a massive surge of electrical power similar to a strong radio signal. It comes from the nuclear explosion and is transmitted through the air in all directions. It occurs immediately after a nuclear device explodes. It can damage electrical components of equipment (radios, radars, and vehicles) and weapon systems (TOW and Dragon) if proper precautions are not taken. EMP does not harm soldiers. Equipment can be protected against EMP by using protective devices where signals can enter (antenna and cable terminals) to divert energy to the ground, and by properly shielding circuits from outside electromagnetic fields. Much protection can also be provided by using techniques to minimize exposure to EMP and by reducing the amount of EMP energy going into the circuits from outside sources. The first step is to teach everyone about EMP and its effects on equipment. Secondly, soldiers should take steps to reduce EMP exposure by grounding all connecting cables as much as practical and by placing them in metal conduits.

b. Warning of a Nuclear Explosion or Hazard. Information about possible enemy use of nuclear weapons is forwarded to companies and platoons through the chain of command by the quickest and most secure means. The communication to the platoons need contain only—

- A proword indicating that the message is a nuclear strike warning.
- A brief message, IAW SOP, that directs the platoon either to take specific protective actions or to evacuate the area.

c. Alarm for Nuclear Hazard. As soon as a soldier using a monitoring device detects a nuclear hazard, he should warn others. The alarm must be passed swiftly throughout the platoon. The standard alarm is to yell "FALLOUT." The same warning is used when the platoon moves into an area contaminated by residual radiation. The "ALL CLEAR" is used to indicate that the danger no longer exists. Normally, the all clear signal is first given by the company commander or a platoon leader and then repeated by each soldier when he hears it.

d. Nuclear Protective Measures. A soldier can get protection against many nuclear effects by taking cover in a fighting position, culvert, or ditch behind a hil; or inside a BFV in defilade. In most cases, a fighting position with overhead cover or a BFV in defilade offers the best protection. When a platoon, without warning, is subjected to an enemy nuclear attack, personnel exposed in BFV hatches should immediately get down in the vehicle and close the hatches, door, or ramp. They should also lower blackout curtains over vision blocks. Dismounted exposed soldiers should immediately close their eyes, and fall to prone and head-on positions. They keep their heads and faces down until the blast wave passes and debris stops falling. As soon as possible, leaders should reestablish command, communication, and security; and send the initial NBC 1 report. Action should be taken to start continuous monitoring. The platoon uses the NBC 4 report format to send its findings to the company commander.

e. Radiological Monitoring. Radiological monitoring is the detection (presence and intensity) of residual radiation by the use of radiacmeters. Monitoring is essential down to squad level to prevent overexposure to radiation. The IM-174 or AN/VDR-2-series radiacmeters are the instruments used for area monitoring and survey. The IM-93 or DT 236 dosimeters are the instruments used to measure total dose radiation received by soldiers. Accurate dose records must be kept to avoid overexposing soldiers and to keep the total dose relatively equal within a platoon. If a squad is deployed under its leader's control, it should carry and monitor the dosimeters. If the platoon is deployed with a dismount element and a fighting vehicle element, each element leader should monitor a dosimeter. The two types of monitoring techniques are periodic and continuous. Platoons return to periodic monitoring when ordered by a higher echelon or when the radiacmeter reading falls below 1 cGy per hour.

(1) Periodic monitoring requires frequent checks and readings of the platoon area for radiation at least once each hour with the IM-174. Platoon SOPs may require more frequent readings and detailed information when monitoring.

(2) **Continuous** monitoring requires the continuous surveillance for radiation in the platoon area or position. The platoon begins monitoring when—

- A nuclear detonation is observed or reported.
- An NBC 3 nuclear report is received from higher headquarters.
- A dose rate of 1 cGy per hour is recorded during periodic monitoring. (Centigray is a unit of absorbed dose of radiation formerly called a rad.)
- Ordered by higher.

2-54. OPERATIONS IN A CHEMICAL AND BIOLOGICAL ENVIRONMENT

Threat forces have both chemical and biological weapons that may be used separately, together, or with nuclear and conventional weapons. No matter how these weapons might be used, the BFV platoon and squad must be able to survive and carry on the fight. To ensure this, soldiers must be trained to meet the NBC standards of proficiency prescribed in STPs 21-1-SMCT and 21-24-SMCT, and FM 3-100.

a. **Characteristics of Chemical and Biological Agents.** Chemical agents are used to cause casualties, disrupt movement, and restrict the use of terrain. They may be delivered as a gas, liquid, or spray by artillery, mortars, rockets, missile, aircraft, bombs, and land mines. Besides causing casualties, chemical agents can be used to cause confusion. Biological agents produce disease. These agents may be dispersed by generators, artillery, bomblets, rockets, and aircraft. They also may be spread by the release of insects such as flies, mosquitos, fleas, and ticks.

(1) **Effects of chemical agents.** Chemical agents enter the body through the eyes, nose, mouth, or skin. Liquid agents may contaminate equipment, the ground, and foliage. The agent may stay for hours or days and be a serious hazard to unprotected soldiers. Chemical agents cannot destroy the BFV or its equipment. They can restrict equipment use until the equipment is sufficiently decontaminated to reduce the hazard. At platoon level, soldiers can decontaminate only the mission-essential areas (driver's controls, gunner's controls, and individual weapons). So all personnel must continue to wear protective masks, overgarments, overboots, and gloves once chemical contamination has occurred. All leaders and soldiers must know what their responsibilities are and the techniques for decontamination operations in accordance with FM 3-5.

(2) **Alarms for chemical hazard or attack.** Standard alarms include the vocal signal "GAS," prescribed arm-and-hand signals, automatic

chemical-agent alarms, rapid and continuous beating on any metal object that produces a loud noise, a succession of short blasts on a vehicle horn or any other similar device, or a broken warbling siren sound (example, 10 seconds on, 10 seconds off). The vocal signal "ALL CLEAR" indicates that the danger no longer exists. Normally, it is initiated by leaders (company commander or platoon leader) after prescribed unmasking procedures have been completed. (Figure 2-114.)

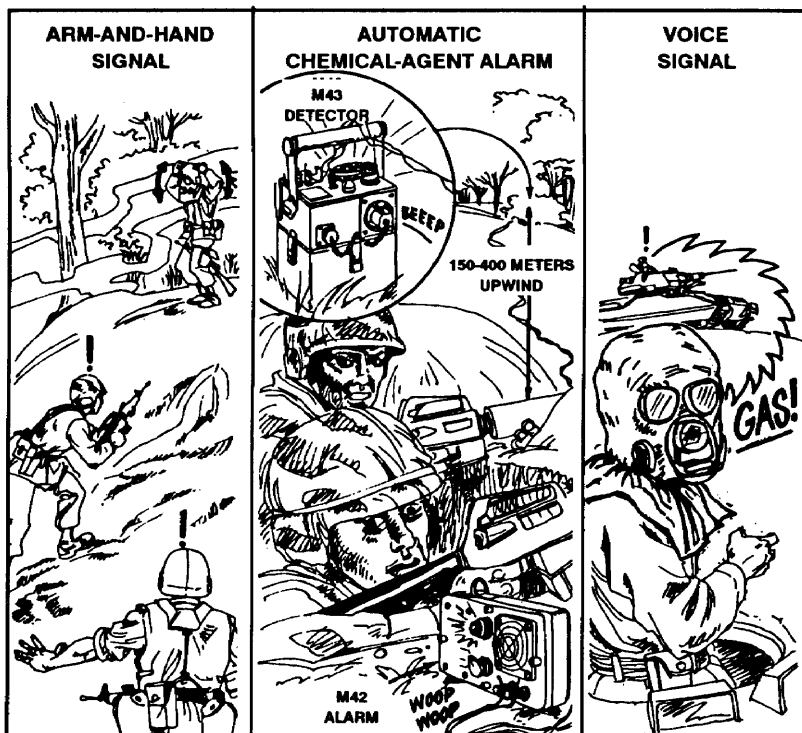

Figure 2-114. Standard alarm signals.

b. **Protective Measures in Chemical and Biological Warfare.** In a chemical or biological attack, the MOPP gear is the best protection. Strict enforcement of all preventive medical and field sanitation measures can further enhance NBC defense.

(1) **Chemical attack.** A soldier's primary protection against chemical attack is his protective mask, which protects against inhalation of chemical agents. To be fully protected against liquid chemical agents,

soldiers must wear the chemical protective overgarments, the mask with hood, overboots, and rubber gloves. (Figure 2-115.)

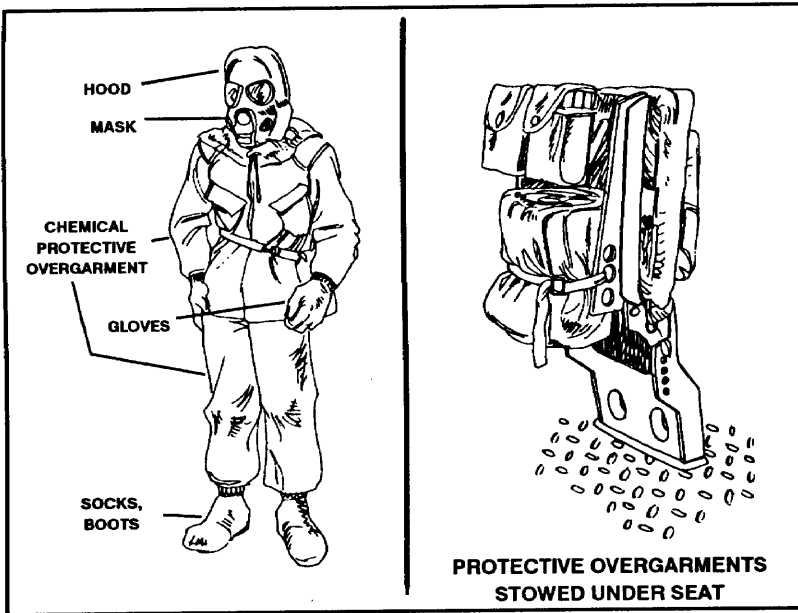

Figure 2-115. Protective equipment and overgarments.

(a) If enemy use of chemical weapons is likely, each soldier in the vehicle should wear his protective mask on his chest to hasten masking. If the commander directs, or the MOPP level dictates, the protective overgarments and masks are worn rather than carried in the stowed positions.

(b) Once a chemical hazard is detected, all individuals should immediately mask and put on their protective overgarments if not already wearing them. It is difficult for everyone to put on protective overgarments at the same time in the BFV. To avoid confusion while dressing in the vehicle, platoon SOPs should dictate the sequential dressing of individuals in certain seats. This would also provide for maintaining security.

(c) If an attack is reported to be imminent or if chemical agents have already been employed by enemy forces, individuals should automatically mask when—

- Chemical alarms or detection kits indicate presence of chemical agents.

- Any artillery, mortar, rocket, or aircraft attack with other than HE munitions occurs on or near their position.
- Smoke or mist of an unknown source arrives in the area.
- A chemical attack is suspected for any other reason, such as enemy soldiers seen wearing protective masks and clothing, or presence of dead animals or people with no outward sign of injury.
- The platoon must enter an area known to be or suspected of being contaminated by a chemical or biological agent.
- Soldiers have any of the following symptoms: A runny nose; a feeling of choking or tightness in the chest or throat; blurred vision or difficulty in focusing irritation of the eyes, nose, or throat; or difficulty in, or increased rate of, breathing.

(2) **Biological attack.** Definite information on enemy use of biological agents may come down from higher headquarters. Still, each platoon must be alert to the danger and report at once any unusual occurrence of disease. The best local defense against biological warfare is strict enforcement of all preventive medical measures (prescribed immunizations) and field sanitation measures as well as high standards of personal hygiene. Soldiers should eat and drink only from approved sources.

c. **Chemical Detection Equipment.** Chemical detection equipment includes the M8A1 automatic chemical-agent alarm, M256 chemical-agent detector kit, ABC-M8 chemical-agent detector paper, the M9 chemical-agent detector paper, and the CAM (chemical-agent monitor). (Figure 2-116, page 2-222.)

(1) The M8A1 automatic chemical-agent alarm produces an audible or visual signal when it detects the presence of nerve agents in the air. It is stowed inside the BFV on the right rear wall. To detect chemical agents, personnel must remove the M8A1 alarm from the vehicle, assemble according to TM 3-6665-225-12, backpack, or mount externally, and place into operation.

(2) The M256 chemical-agent detector kit is used to detect sublethal vapor concentration of nerve, blister, and blood agents. The kit should be used when a chemical attack has occurred or when the presence of a chemical agent is suspected. (Figure 2-117, page 2-222.)

(3) ABC-M8 chemical-agent detector paper comes in a 25-sheet booklet. The booklet is a component of the M256 chemical-agent detector kit and the individual protective mask. The paper sheets are treated with chemicals that turn dark green, yellow, or red when in contact with liquid V-type nerve agents, G-type nerve agents, or blister (mustard) agents, respectively.

This paper must touch the liquid agent to be sure of a positive test; it does not detect vapor. It is best suited for use on nonporous material such as metal. The test is not always reliable on porous material (such as wood or rubber) that can absorb the liquid agent. Many substances (including some solvents and decontaminates) can also cause a color change in this paper; hence, it is only reliable as an indicator of the possible presence of a chemical agent. Positive detector-paper tests should be verified using the chemical-agent detector kit.

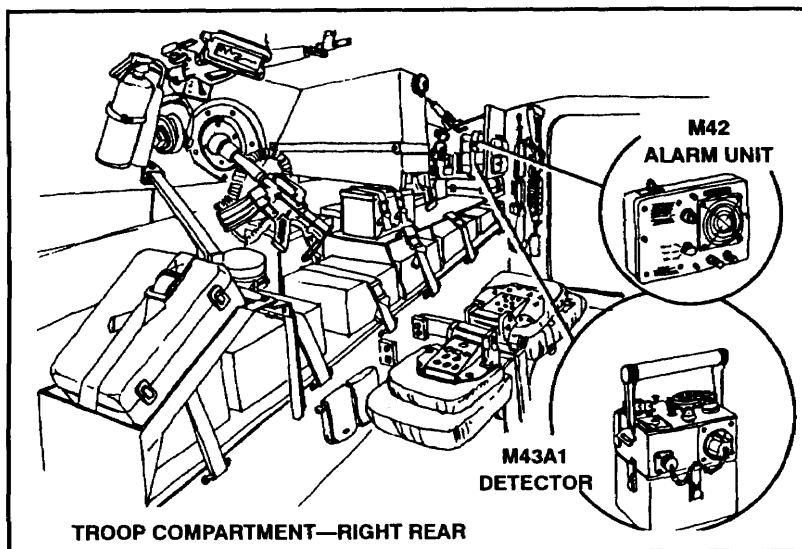

Figure 2-116. Alarm detector.

(4) The M9 chemical-agent detector paper is gray-green and has an adhesive back. The adhesive back is protected by a white paper backing until dispensed from the roll. The paper is 2 inches wide and 30 feet long. Each roll is contained in a cardboard dispenser equipped with a cutter edge. The dispenser is packaged in a foil-type shipping bag. A resealable plastic storage bag is included for storing the dispenser

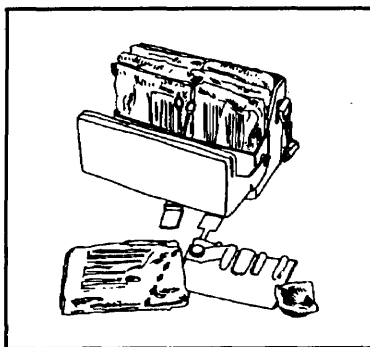

Figure 2-117. Detector kit.

after removal from the shipping bag. The detector paper detects a chemical agent during all types of weather conditions. It is worn by individuals or attached to vehicles or a piece of equipment. The detector paper indicates the presence of a liquid chemical agent. When a liquid chemical touches the paper, a pink, red, red-brown, or red-purple spot appears. The spot may be as small as a pinhead or as large as a dime.

(5) The chemical-agent monitor (CAM) is a portable, hand-held instrument used to determine and indicate a vapor hazard of G-series nerve agents and H-series blister agents in the air. The CAM is used to search for clean areas, to detect and locate contamination on personnel and equipment, and to monitor for the effectiveness of decontamination operations. The CAM is sensitive enough to monitor levels of contamination at the lowest concentration levels that could affect personnel over short periods. The CAM displays concentration levels on a liquid crystal display.

d. Individual Actions Before a Chemical Attack. If a platoon determines that it is subject to an imminent chemical attack or downwind vapor hazard, each individual should take the following precautionary measures:

- Assume MOPP2, 3, or 4 (depending on the situation).
- Attach M8/M9 paper to personnel and vehicles.
- Cover as much equipment as possible.
- Ensure chemical-agent alarm is operating.
- Ensure decontamination equipment is accessible.
- Be prepared to move from location.

e. Individual Actions During a Chemical Attack. Soldiers may be affected by a chemical attack either directly on or upwind from their positions. In either case, the soldiers should immediately stop breathing, put on their protective masks, clear masks, check for seal, give the alarm, don protective clothing if not on already, and continue the mission.

(1) If the attack is recognized as a chemical spray attack, soldiers should use a protective cover, such as a poncho or shelter half, to further protect themselves from liquid droplets. After the spray has stopped falling, individuals can throw off the cover, avoiding contaminating clothing and equipment.

(2) When friendly forces use chemical agents, the headquarters directing the fire mission provides the necessary safety information to friendly platoons that may be affected by the mission. Individuals take

the same protective measures they would take against a similar type of enemy chemical attack.

f. **Individual Actions After a Chemical Attack.** Each soldier should remain masked and continue his mission. He should give any needed first aid to casualties in the near area and report the local casualty status to his next higher leader. Contaminated skin, clothing, and equipment should be decontaminated as soon as possible.

DANGER

AFTER A CHEMICAL ATTACK, SOLDIERS SHOULD NOT UNMASK UNTIL AUTHORIZED BY THEIR IMMEDIATE COMMANDER.

g. **Conditions of Unmasking.** In the absence of command guidance, the procedures described below are followed by the senior person present.

(1) **Procedures when a detector kit is available.** The chemical-agent detector kit M256 is used to test for the presence of chemical agents. If there is not any evidence of agents, two to three individuals unmask for 5 minutes, then remask. They are observed for chemical-agent symptoms for 10 minutes in a shady area. (A shady area is used because light causes contraction of the pupils, which could be mistaken for a nerve-agent symptom.) If no symptoms appear, the rest of the soldiers may unmask. Soldiers are warned to remask immediately if anyone suspects that a chemical agent may be present.

(2) **Procedures when a detector kit is not available.** The following is an emergency field expedient when friendly elements have been masked for prolonged periods, when there are no remaining signs of chemical agent use, and when the platoon has no detector kit available. Two to three soldiers are selected to hold deep breaths, break the seals of their masks, and keep their eyes wide open and hold their breath for 15 seconds. They then clear their masks, reseal them, and wait for 10 minutes. If symptoms do not appear after 10 minutes, the same soldiers again break their seals, take two or three breaths, and clear and reseal their masks. After another 10-minute wait, if symptoms have not developed, the same soldiers unmask for 5 minutes and then remask. After 10 more minutes, if symptoms have not appeared, they report to the company/team commander and wait for instructions before unmasking. The area can be assumed to be all clear and the commander may

order unmasking. Soldiers are warned to remask if for any reason they may suspect a chemical agent is present.

h. Mission-Oriented Protection Posture. Once chemical agents have been employed or while the threat of enemy chemical attack exists, the battalion commander decides whether to keep all soldiers masked and in chemical protective clothing, or only a certain number. This decision is based on the estimated threat of enemy use of chemical weapons, mission of the battalion, type of activity required, and temperature. The steps taken are expressed as a MOPP level. Whenever possible, the commander specifies the MOPP level before the mission. He may later direct that the protection be modified, based on his on-the-spot estimate of the situation and operational limitations. The MOPP level directed by the battalion commander specifies what equipment to wear and what precautionary measures are to be employed. (See Table 2-7, page 2-226, for the protective clothing and equipment required under the various MOPP conditions.) Additionally, there is a special category of MOPP known as “mask only.” The “mask only” command may be given if there is no transfer hazard and if the agent is determined to be nonpersistent. These levels apply to the individuals inside or outside the vehicle in all cases. The following factors should be considered by the platoon and squad leader when working under any of the MOPP conditions.

(1) **Heat exhaustion.** Soldiers operating at moderate to heavy work rates while in chemical protective gear may experience heat exhaustion (dizziness and fainting) at anytime, especially in hot weather. Because of increased sweating, they need more drinking water than normal.

(2) **Fatigue.** Soldiers in full chemical protective clothing and equipment tend to experience fatigue because of such factors as mask breathing resistance, rise in body temperature from work energy, solar heat, and psychological and physiological stress. This condition of fatigue increases the need for more rest breaks and sleep to maintain individual alertness and efficiency.

(3) **Senses.** Soldiers who are required to perform duties involving the senses or related functions, such as manning an observation post, tend to operate at lower levels of efficiency while wearing protective equipment. Individual performance levels depend on training and proficiency. Even simple functions, such as talking on the radio and looking through weapon sights, become difficult while wearing the protective mask.

(4) **Personal needs.** Soldiers cannot be in full chemical protection for indefinite periods and still attend to certain personal needs such as eating, caring for wounds, shaving, and eliminating body wastes. The platoon

leader should plan for these needs by coordinating with the company commander for movement to an uncontaminated area.

MOPP	OVERGARMENT	BOOTIES	MASK/HOOD	GLOVES	TIME REQUIRED
0 (UNLIKELY)	Carried	Carried	Carried	Carried	
1 (POSSIBLE)	Worn, opened or closed based on temperature	Carried	Carried	Carried	MOPPO-1 4 min
2 (POSSIBLE)	Same as MOPP 1	Worn	Carried	Carried	
3 (LIKELY)	Same as MOPP 1	Worn	Worn, hood opened or closed based on temperature	Carried	
4 (IMMINENT)	Worn, closed	Worn	Worn, closed	Worn	MOPPO-4 8 min
MASK ONLY (SPECIAL CATEGORY)	Carried	Carried	Carried	Carried	

Table 2-7. MOPP levels and protective equipment.

i. **Chemical Decontamination Techniques.** When a force is chemically contaminated, its combat potential drops. In order to minimize the erosion of combat potential, decontamination must be performed. (Table 2-8.) The seven standard techniques used to remove contamination and restore combat potential are—

- Skin decontamination.
- Personal wipedown.
- Operator's spraydown.
- MOPP gear exchange.
- Vehicle washdown.
- Detailed troop decontamination.
- Detailed equipment decontamination.

The platoon would be involved in and should have knowledge of at least the first five techniques. The first three techniques are categorized as basic skills decontamination techniques. The next two, MOPP gear exchange and vehicle washdown, are hasty decontamination techniques. The purpose of hasty decontamination is to sustain the combat potential of a contaminated force by limiting spread of the contamination. The benefits gained may allow temporary relief or MOPP reduction. Hasty decontamination should be done as soon as possible. A squad can do both of the techniques in about 45 to 60 minutes as it moves among the fighting position. These techniques should begin within 6 hours. The vehicle washdown is most effective if it is started within an hour of contamination.

DECON TECHNIQUE	BEST START TIME	DONE BY	TECHNIQUE	GAINS MADE
BASIC SKILLS	Before 1 minute	Individual	SKIN DECON	Stops agent from penetrating
	Within 15 minutes	Individual or crew	PERSONAL WIPEDOWN 3-5 minutes	
			OPERATOR'S SPRAYDOWN 1 vehicle spraydown—2-3 minutes then wait 30 minutes to remove contamination	
HASTY DECON OPERATION	Within 6 hours	Unit	MOPP GEAR EXCHANGE 12 soldiers—1 hour	Possible temporary relief from MOPP4. Limit liquid agent spread.
		Bn crew or decon squad	VEHICLE WASHDOWN 1 vehicle—2-3 minutes	
DELIBERATE DECON OPERATION	When mission allows reconstitution	Unit	DETAILED TROOP DECON 12 soldiers—1 hour	Probable long-term MOPP reduction with minimum risks.
		Decon	DETAILED EQUIPMENT DECON 4 vehicles—1 hour	

Table 2-8. Decontamination techniques.

(1) **Skin decontamination.** If chemical agents get on bare skin, it is an emergency. The best technique for removing or neutralizing this contamination is by using skin decontamination. This is a basic soldier survival skill and is performed using the M258A1 skin decontamination kit. Decontamination should begin within one minute to be most effective.

(2) **Personal wipedown.** The personal wipedown technique removes or neutralizes contamination on the hood, mask, gloves, and personal weapon. Soldiers also use the M258A1 skin decontamination kit to perform personal wipedown. (Figure 2-118.) Personal wipedown should begin within 15 minutes of being contaminated.

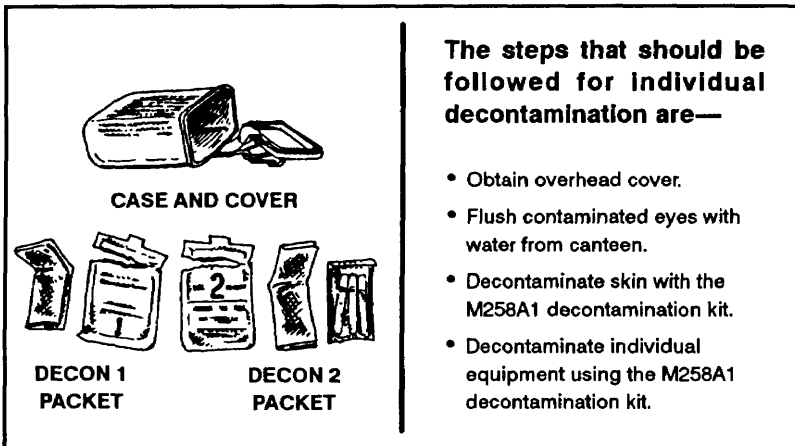

Figure 2-118. M258A1 skin decontamination kit.

(3) **Operator's spraydown.** The operator's spraydown technique should begin right after finishing personal wipedown. The spraydown removes or neutralizes contamination on surfaces that operators must frequently touch to do their missions. This can be done using the ABC-M11 or M13 portable decontamination apparatus, which dispenses DS-2. (Figure 2-119.) Each vehicle has one M11 decontamination apparatus that contains 1 1/3 quarts of DS-2 decontaminating agent and one can of DS-2 replacement fluid or one M13 decontamination apparatus, which has a capacity of 14 liters of DS-2. These are on the interior left front of the BFV, behind the driver. The M11 decontamination apparatus is used to decontaminate vehicle parts that must be touched to operate the vehicle. These areas include the driver's compartment and the turret controls.

DS-2 must be removed by washing after 30 minutes contact time to prevent corrosive damage to the equipment. MOPP4 gear must be worn when using DS-2.

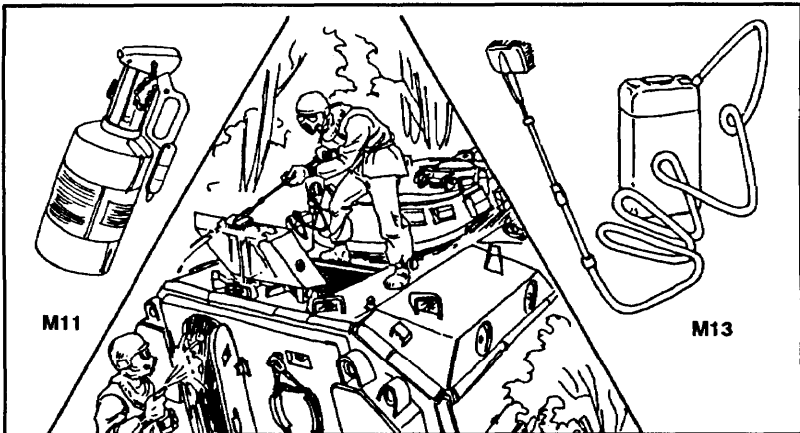

Figure 2-119. Decontamination apparatus.

(4) *MOPP gear exchange.*
The MOPP gear exchange is conducted by the contaminated squad (occasionally platoon) and supported by company NBC NCO and the company supply section that provides decontaminants and new overgarments. When performing MOPP gear exchange, soldiers are paired into buddy teams. The teams are spaced around a circle, with 1 to 3 meters between each team. (Figure 2-120.) (See FM 3-5 for a detailed explanation.)

STEP	ACTION
1	Gear drop
2	Hood decon
3	Overgarment off
4	Boots and gloves off
5	Overgarment on
6	Boots and gloves on
7	Secure hood
8	Secure gear

Figure 2-120. MOPP gear exchange.

(5) **Vehicle washdown.** The vehicle washdown is supported by the battalion's power-driven decontamination equipment crew or a chemical company decontamination squad. The vehicle washdown greatly reduces the transfer hazard on equipment. Every vehicle is washed with hot soapy water for two to three minutes. Because speed is important and detection is difficult, vehicles are not checked for contamination after vehicle washdown is completed. Only gross contamination is removed. See FM 3-5 for a detailed explanation.

(6) **Detailed troop and detailed equipment decontamination.** Detailed troop and detailed equipment decontamination are classified as deliberate decontamination operations. Deliberate decontamination operations remove sufficient amounts of contamination to allow soldiers to safely operate the equipment at reduced MOPP levels for extended periods. It requires that the platoon be taken out of battle; however, when it is finished decontaminating, the platoon has its combat power restored. It will no longer need to operate in full MOPP4. Deliberate decontamination is done as part of an extensive reconstitution effort in brigade, division, and corps support areas. Ordinarily, the chemical unit selects a site, sets it up, and conducts the equipment decontamination with assistance from the contaminated platoon. The troop decontamination is set up and operated by the contaminated platoon with some technical assistance from the chemical unit.

(a) Key weapon systems (TOW, 25-mm gun, and coaxial machine gun) are decontaminated by using DS-2, soapy water, or solvents. Ammunition is decontaminated by washing with soapy water, wiping with organic solvent, drying, and aerating.

(b) Optical instruments, such as the integrated sight unit and starlight scopes, are decontaminated by using the M258A1 kit or blotting with rags, wiping with lens-cleaning solvent provided with the sight, and then allowing them to dry.

(c) Communication equipment is decontaminated by airing, weathering, or hot air (if available). The metal parts of field telephones and radios are decontaminated with DS-2 and then wiped with rags.

(d) For biological decontamination, the BFV can be decontaminated by applying STB slurry. It is left on for 30 minutes, then removed by washing. (STB is provided to platoons by the company headquarters, which gets it from the battalion supply section.) The BFV is washed with a detergent solution and rinsed with a high-pressure water stream, or it is steamed clean, using a detergent.

(e) Weapons are decontaminated using household bleach solution or soap and water. Working parts and surfaces should be dried and

lubricated after decontamination. Contaminated clothing is disposed of by burning or burying, or decontaminated by laundering.

NOTE: The techniques become increasingly less effective the longer they are delayed. Vehicle wash down is most effective if started within one hour but will often have to be delayed for tactical and logistical reasons.

Section XII OBSERVATION POSTS

Observation posts are positions from which soldiers watch and listen for enemy activity in a designated area. OPs provide security and intelligence for the platoon. OPs are normally designated to observe critical areas for the platoon or as the company commander directs.

2-55. CONSIDERATIONS

When planning an OP, the platoon leader must consider the following:

a. **Location.** Normally the platoon leader identifies the general location, and the squad leader selects the site for the OP. OPs must be sited to allow for maximum observation of the designated area. They should also be sited to take advantage of natural cover and concealment to provide protection for the soldiers manning it. OPs should be within the range of the platoon's direct-fire weapons when manned by a dismounted element (except in reverse-slope defense).

b. **Observation.** When he identifies the general location for the OP, the platoon leader must also indicate the area to be observed and any specific instructions covering what soldiers are to look for or be alert to. Mounted or dismounted OPs should require minimal repositioning for limited visibility conditions.

c. **Cover and Concealment.** Sometimes the requirement for fields of observation may make it difficult to achieve cover and concealment. Some techniques include—

- Avoiding obvious terrain such as hilltops.
- Avoiding easily identifiable terrain features such as water towers, church steeples, tallest buildings, lone buildings or trees, or isolated groves.

- Avoiding routes or positions that skyline soldiers and vehicles.
- Selecting a covered and concealed route to and from the OP.

d. **Communications.** Soldiers must be able to report what they see and hear. Wire is the primary means of communications between the OP and the platoon. If possible, the OP should have radio communications as a backup. A soldier may be added as a messenger if no other means of communication is available. The platoon SOP should special how often OPs routinely check communications, When the platoon loses wire communications with the OP, the leader always details at least two soldiers to check and repair the line—one for security, one for repair. Soldiers checking for breaks in wire should always approach the OP with caution in case the enemy has captured and occupied it.

e. **Manning.** At least two soldiers must man each OP. Afire team may man the OP if it will remain in place or not be relieved for long periods. All soldiers prepare fighting positions at the OP for protection and concealment.

f. **Additional Instructions.** In addition to the intelligence and security reporting requirements, the squad leader also briefs the soldiers manning the OP on the challenge and password, the running password, when to engage and when not to engage the enemy, conditions when the OP can withdraw, when to expect relief, and contingency plans for loss of communications.

g. **Equipment.** Special equipment for the OP includes flags, binoculars, maps, a compass, night vision devices (goggles or an antiarmor thermal sight), trip flares and other alert devices, afield phone, paper and pencil, and a watch.

h. **Thermal Sight Surveillance.** Thermal sight surveillance can be used during unlimited and limited visibility conditions. Image intensifiers, thermal sights, and binoculars should be used together to maximize the OP's ability to observe the area of responsibility. BFVs can be positioned forward with OPs to take advantage of the BFVs' thermal sights. If positioned forward, the BFVs should be employed in pairs. To preserve batteries and fuel, the BFVs alternate operation as designated by the platoon leader or IAW SOP. If the BFVs are positioned forward with the OPs, the surveillance plan must include specific instructions on when and how they should be moved back to the main defensive position to avoid the friendly unit's position from being compromised.

2-56. ACTIONS AT THE OBSERVATION POST

Once the squad leader has positioned and briefed the soldiers at the OP site, one soldier always observes and records while the remainder performs the actions listed below:

- Establish security. Install trip flares and noise-making devices.
- Prepare positions to include range cards. Record data for use in requesting and adjusting fire; for example, azimuths and ranges to TRPs.
- Check or report communications as required.
- Rotate duty as the observer every 20 to 30 minutes. An observer's efficiency quickly decreases after that time.
- Brief relieving soldiers on any information or special instructions before departing the OP. The frequency of reliefs for OPs depends on the physical condition of the soldiers, weather conditions, morale, the number of soldiers available for relief, and the requirements of the next operation. As a guide, OPs should be relieved every two to four hours.
- Withdraw as directed or to avoid capture. Soldiers manning the OP advise the platoon leader that they are returning and request support (direct or indirect) if needed. Leaders must alert all soldiers in the platoon when reliefs move to or from the OP, and when it withdraws.

2-57. SQUAD-SIZED OBSERVATION POST

A squad including its mounted element may be given an OP mission. This affords the OP more firepower, armor protection, and mobility. If manning the OP with the mounted element is not feasible, it can occupy hide positions and prepare to support the OP with fires. The vehicles can also be used to move soldiers between OPs and patrol between them.

2-58. VISUAL TERRAIN SEARCH

A visual terrain search involves the two steps discussed below. OP personnel report all information quickly, accurately, and completely. They make sure that the report answers the questions WHO, WHAT WHERE, and WHEN. It is best to use the SALUTE format when reporting information.

a. **Step 1.** The observer makes an overall search of the entire area for obvious targets, unnatural colors, outlines, or movement. To do this quickly, he raises his eyes from just in front of his position to the greatest range he wants to observe. If the sector is wide, he observes it in sections. (Figure 2-121, page 2-234.)

b. **Step 2.** He observes overlapping 50-meter wide strips, alternating from left to right to left until he has observed the entire area. (Figure 2-122, page 2-234.) When he sees a suspicious spot, he searches it well.



Figure 2-121. Overall search.

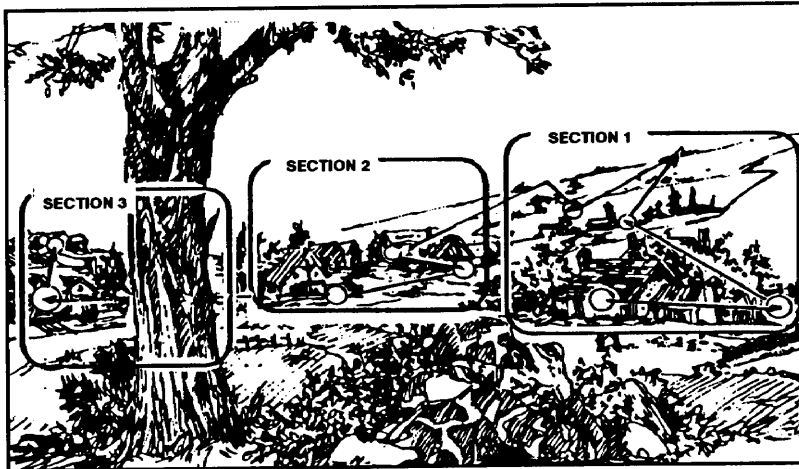

Figure 2-122. Overlapping 50-meter search.

Section XIII

LIMITED VISIBILITY TECHNIQUES

Platoons that have mastered tactical and technical requirements fight effectively even when visibility is limited. Darkness limits visibility on the battlefield, but there are other conditions that limit visibility. They are almost as common as darkness but less predictable and more difficult to deal with. Smoke and suppressive fire, which can severely limit local visibility, are used in all armies. Dust and smoke caused by fire and movement of soldiers often obscure parts of the battlefield. Optic systems provide a distinct advantage. One technique is to use all the platoon's Dragon trackers (daysights and nightsights) 24 hours a day. Thermal sights can be used in the day, in smoke and dust; and the daysight can be used at night along with illumination. Using both sights doubles the number of Dragons that can be employed. Smoke and dust are especially critical to the effective employment of long-range direct-fire weapons. This causes the platoon to decrease the range to engagement areas. Rain, falling snow, fog, and dust also limit visibility. Most night vision devices and battlefield illumination are less effective during these conditions. Therefore, the platoon employs traditional dismounted infantry skills. Observation posts and patrols are used for early warning. Ground surveillance radars and directed-energy weapons also provide early warning, but basic skills, competence, discipline, and leadership are essential.

2-59. EQUIPMENT CONSIDERATIONS

The BFV has the following equipment capabilities to be considered when planning.

a. The driver's night vision viewer allows him to see during darkness to move the BFV and to observe rounds fired from the turret weapons. Night vision goggles allow the Bradley commander to observe from his opened hatch to control movement and provide close-in security. The integrated sight unit's thermal sight gives the gunner and Bradley commander the capability to see and engage targets during almost any visibility condition.

b. Even though the BFV can operate during limited visibility, certain factors must be considered when planning. The driver can see to drive, but the range and fixed field of view limits his ability to provide

close-in observation. The gunner has excellent range with the integrated sight unit, but his field of view is narrow. Soldiers using binoculars in the troop compartment have difficulty observing through periscopes, and they may be blinded temporarily by bright flashes of light caused by weapons fire and explosions. This results in security being degraded, especially to the rear and flanks.

WARNING

To operate the turret when the hatch is open, personnel must ensure it is on combat override. The gunner and Bradley commander must remember that the turret weapons pose a danger to personnel observing from the cargo hatch, especially if the weapons are in the stabilized mode. The 7.62-mm coax could be accidentally fired into the troop hatch and the 25-mm gun could be damaged by striking it.

c. Weather, smoke, and dust lower the effectiveness of the platoon's observation equipment. The integrated sight unit's thermal capability is limited by heavy rain, dense fog, or falling snow. The TOW is also affected. In some cases, the thermal sight's capability of penetrating fog or smoke exceeds the capability of the missile's guidance system to track and control the missile. This means the gunners may not be able to hit a target with the TOW, even though the target is in range and seen through the sight. The 25-mm gun and 7.62-mm coaxial machine gun are not affected by this problem.

d. The effectiveness of image intensification devices (driver's viewer, Bradley commander's goggles, starlight scopes) is reduced by rain, falling snow, fog, and smoke. Because these devices intensify light from the moon and stars, the effectiveness of the devices is reduced on dark nights. These visibility limitations require slower rates of movement and tighter formations, and they limit the platoon's flank security. The Bradley commander's ability to detect targets and control fires is reduced, and coordination between the vehicle element and the dismount element becomes even more difficult.

e. Before an operation, leaders check the effectiveness of their night vision equipment to determine the effects of light, weather, and smoke. Visibility conditions may also change abruptly during an operation. This requires constant reevaluation of employment considerations.

2-60. LIMITED VISIBILITY OFFENSE

Infantry platoons and squads often conduct offensive operations during limited visibility. These are normal operations. Platoon and squads must train to operate during all conditions. Limited visibility attacks are conducted to retain momentum of an operation started in good visibility. They achieve surprise, exploit success, or rupture strong enemy defenses. Leaders may take advantage of the BFV's capability to operate during limited visibility because enemy antiarmor fires will be less effective. Leaders may also want to gain a more favorable position from which they can continue the attack when visibility improves. They should also consider using smoke to create favorable limited visibility conditions on demand.

2-61. MOVEMENT CONSIDERATIONS

Movement is difficult during limited visibility. When selecting movement techniques and formations, leaders consider the likelihood of enemy contact and the difficulty of control. Distances between soldiers or vehicles are usually shortened to ease control. Finally, leaders must guard against a false sense of security by thinking darkness will conceal them. They must assume the enemy has night vision devices; and must use cover, concealment, and smoke as in daylight.

a. If possible, routes are reconnoitered during good visibility. If ground reconnaissance is not possible, a detailed map reconnaissance is vital, keying on terrain features to be crossed and distances involved. Ridgelines, railroads, creeks, and other identifiable features are used as guides. Movement should parallel such terrain features, because the enemy will have them covered by observation and fire. Friendly mortar and artillery fires are also used to assist navigation. By planning targets along the route on prominent, easily recognizable terrain features, leaders can call for these fires as needed. These targets are on dominant features that the leader will avoid. This allows him to call for a specific target and verify where he is without endangering his squad or platoon.

b. When moving dismounted, the attacker has the greatest advantage of surprise. Light and noise discipline must be enforced. When the platoon is moving mounted, vehicle sounds may alert the enemy. The enemy may have difficulty locating the platoon, because it is difficult to pinpoint a moving vehicle by sound only. Lights are a greater danger. Blackout lights and filtered lights are visible through vision blocks and can be detected from great distances with passive night vision devices or the naked eye.

2-62. MOVEMENT FORMATIONS

The platoon uses the following movement formations during limited visibility.

a. **Mounted.** The column and wedge formations are the easiest to control. The platoon leader's BFV serves as the base vehicle in either formation. The platoon sergeant guides on the platoon leader and wingmen guide on their section leaders (platoon leader and platoon sergeant). The line formation is the most difficult to control. When the driver is looking through his night vision viewer to the front, he cannot maintain visual contact with flank BFVs. Therefore, the leader uses the line formation only to move short distances.

b. **Dismounted.** Many of the considerations for mounted formations apply to dismounted formations. Squads move close together for better control, and soldiers should be close enough to see each other. Leaders should be near the front of the formation for movement control.

2-63. MOVEMENT TECHNIQUES

When visibility is limited by darkness only, the platoon should move using any of the movement techniques, making only minor adjustments as previously discussed. When smoke, fog, or falling snow limits visibility, the platoon's ability to provide overwatch may be reduced. In all conditions of limited visibility, the loss of security to the flanks **and** rear is a major consideration in movement planning.

a. A platoon moving by traveling overwatch keys its movement on the lead element. The distance between elements is based on the ability of the overwatch element to keep the lead element in sight. The integrated sight unit on the BFV should not be used as the primary means for maintaining visual contact. This requires the gunner and Bradley commander to watch the bounding element rather than to watch for the enemy.

b. When the traveling technique is used, the lack of flank security becomes an even more important consideration. The wedge formation allows a greater number of thermal sights to be used, and they should be used if the terrain permits.

2-64. NAVIGATION TECHNIQUE

Navigation during limited visibility becomes difficult. Vehicle thermal sights and night vision goggles aid leaders, but it is still easy to confuse terrain features and to become disoriented or overshoot objectives. BCs find it difficult to switch from reading a map to viewing terrain through goggles. Constant practice improves the leader's ability to navigate at night. Soldiers must be thoroughly briefed on the type of terrain and the general environment they will encounter, including water sources (if any) landmarks or significant permanent terrain features, friendly and enemy areas of operation, and prevailing winds. This information will

assist in navigation if reconnaissance units or individuals become separated from their units.

a. **Compass and Odometer.** One method of navigating during limited visibility is to use a compass (dismounted) and the odometer. This can be done as follows (see Figure 2-123, page 2-242, for an example):

- Divide the route or operation into legs or parts, each with a unique direction and distance and a checkpoint to find.
- Measure the map distance of each leg or part.
- Determine the azimuth of each leg or part.
- Develop a chart to include the legs or parts, azimuths, and distances. Also write a description of each leg or part.
- Use the odometer to measure the distance traveled.
- Review the written description of the route to help prevent navigational errors.
- Set the turret in the direction of movement and keep the stabilization on.

b. **Gyro Compass.** An efficient gun azimuth stabilizer used on nearly flat ground is useful for maintaining direction.

c. **Fires.** Planned tracer fire assists in maintaining bearing, and field artillery and mortar concentrations preferably smoke (or illumination at night) are useful checks on estimated locations.

d. **Radars.** If the position of a radar is known, it can measure range and bearing and therefore locate the position of a vehicle.

e. **Global Positioning Systems.** These systems are receivers that receive signals from satellites or land-based emitters and calculate and display the position of the user in military grid coordinates and latitude and longitude degrees. Leaders must continue to use map and compass navigation as the primary means, because satellite signals can be interrupted by vegetation, weather, or other masking features; or the inoperative emitters.

(1) **Waypoints.** The navigational functions of GPSs are based on waypoints. A waypoint is a known position entered into GPS's memory. Waypoints can be entered as either degrees latitude or longitude or as military grid coordinates. Waypoints or the platoon's position can be entered at various times.

(2) **Navigation.** To navigate, points along the route or the destination point is identified. Next, these points are entered as waypoints. Then, the platoon moves from waypoint to waypoint. To find the distance and direction between two known points, they must first be entered as waypoints.

(3) **Range and bearing.** To find the range and bearing to a known point, that point must first be entered as a waypoint. GPS stores the present position and then computes the distance and direction to the known point. As the platoon approaches the waypoint, the range decreases until the platoon is within a given distance of the waypoint. At that time, an alarm will sound indicating that the platoon has reached the waypoint. Then, the range and bearing to the next waypoint can be displayed.

(4) **Cross-country navigation.** When navigating cross country, the bearing shown by the GPS can be followed from point to point. Obstacles en route will force detours from the route from time to time. When an obstacle forces a detour of more than a few meters, the GPS can assist the platoon in getting back on course. Some GPSs display the distance that the platoon is off course, a new course to the waypoint, and an estimated time to arrive based on the speed for the last two minutes. The left or right arrow shows the direction to the original course. The arrow shows the direction the platoon needs to turn and a new bearing to the waypoint. If the platoon needs to reach the desired point and the route to it is not important, then the platoon follows the indicated course. The course shown is the new direction the waypoint and will not return to the original course. If the original course must be used, then the platoon uses the direction of the arrow and travels the distance indicated until the GPS shows no error.

(5) **Road march.** GPS can be useful on road marches in identifying checkpoints or coordination points on long roads without distinctive features. The waypoint for the checkpoint is entered and the range and bearing display is selected. Then, the platoon moves until the alarm sounds. In this case, the bearing to the waypoint is of little use, because the platoon is following a road and there will be numerous deviations from the straight-line bearing. If the platoon enters a road at an unknown point, the bearing could be a quick way to determine the direction to the waypoint.

(6) **Offensive operations.** The GPS can locate a platoon's position within an assembly area. A waypoint with the grid location of the center unit's area ensures proper placement within the assembly area. Waypoints at the start point, the release point, and along the route help to guide the unit to the line of departure.

(a) After crossing the line of departure, key points along the axis of advance can be entered as waypoints to help guide the platoon. Additional waypoints on checkpoints or coordination points help to identify their locations.

(b) Phase lines are necessary to coordination of the attack, but the terrain does not always lend itself to easily identifiable phase lines. With the GPS, phase lines can be placed without reliance on terrain features. The border alert feature sounds an alarm when the platoon reaches a designated line on the ground. The same method can be used for locating a limit of advance line.

(c) Once on the objective, the platoon consolidates and reorganizes. In directing the platoon's defensive fire orientation, a distant point (such as a TRP) can be selected and entered as a waypoint. The platoon then takes a range and bearing to the point and uses that bearing as its orientation. If fuel and ammunition resupply is not performed at the platoon location, that site can be entered as a waypoint to aid in its location; likewise, for collection points for maintenance, EPWs, and wounded.

(7) **Defensive operations.** In establishing a battle position, the platoon can use the anchor watch feature of most GPSs to ensure that all elements are within the proper area. The anchor watch sounds an alarm whenever the platoon gets too far from a designated point. The desired range is entered. The range is the distance from the center point that the platoon will go before sounding an alarm. Once a vehicle has established its location on primary and subsequent battle positions, that location can be saved as a waypoint to aid in finding it again later.

(a) GPS can also assist movement from one battle position to another, particularly during limited visibility. During the reconnaissance and rehearsal of the route, the platoon enters the waypoints at all critical locations (such as trail crossings, fords, obstacles, or turns). To do this, whenever the platoon comes to a critical point, it stops and saves the present position as a waypoint. Each point is saved in sequence. Then the platoon can follow the sequence of waypoints between the battle positions.

(b) Waypoints can also be used to ensure orientation of fires using the range bearing feature.

(c) Movements, in a passage of lines, the unit that establishes the passage can give grid coordinates of entry points, release points, and critical turns to the passing unit. These coordinates are entered as waypoints. The passing unit can then follow the waypoints and ensure a safe passage without danger of getting lost or wandering into obstacles.

LEG/PART	AZIMUTH	DISTANCE	DESCRIPTION OF ROUTE TRAVELED
AA BLUE to SP	180°	2.5 miles	From AA BLUE, travel downhill to the SP, a three-way, hardtop intersection.
SP to 10	87°	5.5 miles	At the SP, turn left and travel on a flat hardtop road for about 4 miles. The road becomes uphill as you approach the four-way intersection (10). A downhill grade on azimuth will mean 10 has been passed.
10 to PP1	183°	6.3 miles	At 10, turn right and travel downhill for 6.3 miles, linking up with the XO at PP1. The PP is 400 meters past a bridge and is near two houses.
PP1 to 12	92°	7.4 miles	At PP1, turn left and travel a flat, cross-country stretch for 7.4 miles until you reach three houses (12). Reaching an uphill grade or a hardtop road along the same azimuth will mean 12 has been reached.
12 to 5	60°	5.5 miles	From 12, travel on a 60° azimuth uphill for about 5.5 miles, crossing a dirt road and a hardtop road. At hill (5), tanks will be oriented on a 90° azimuth.

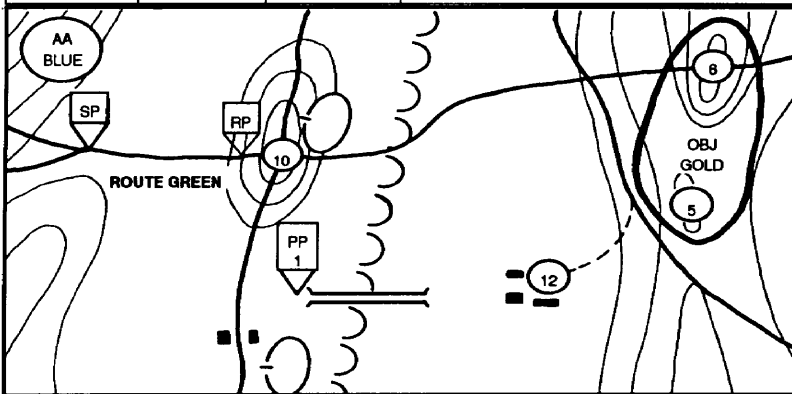

Figure 2-123. Route chart.

2-65. IDENTIFICATION

One of the platoon leader's problems is recognizing his own vehicles at night. Platoons employ several techniques for vehicle identification to avoid fratricide and to enhance command and control. Using color-coded lights on the rear of the turret is a common technique (for example, red lights for A section, blue for B section, and green for dismount elements). Lights must be dim so they are not visible from the front, but can still be seen from the rear. Chemical light stick combinations can also be used. Another technique is to use white or luminous tape to outline the geometric design and numbers of the platoon's tactical marking system. Another technique is to use hot packs, which can be ordered through the Class VIII supply channels.

2-66. ATTACKS

Attacks during limited visibility require more control measures than attacks during good visibility. In limited visibility, objectives are normally smaller and the distance to them shorter. Plans must be kept simple but complete and understood by all to prevent fratricide and to enhance mission accomplishment. If time and the enemy situation permit, leaders should reconnoiter routes and observe the objective area during good visibility, at dusk, and during darkness. Indirect fire should be planned for suppression and illumination during darkness. Whether the attack is mounted or dismounted, every soldier should rehearse his portion of the plan to ensure complete understanding throughout the platoon.

a. There are several ways the commander may attack during limited visibility. If the attack is to be done during darkness, he may illuminate the battlefield using indirect fire. The driver's VVS-2 fades out while illumination is being used. This blinds the driver. The leader should consider having only half of the platoon use VVS-2. If the leader wishes to take advantage of limited visibility conditions or cannot adequately illuminate the battlefield, he may consider dismounting short of the objective. He may also attack dismounted and use stealth to gain surprise. If the LD or assault position is close enough to the objective, BFV thermal sights can be used to vector dismounted infantry to the objective, and then support the dismounted assault with direct fire.

b. An illuminated night attack is conducted similar to a daylight attack. Even with illumination, soldiers cannot see well enough to fight effectively mounted. Illumination, however, aids control and allows rapid movement. It also improves the enemy's ability to detect targets. Illumination fires are planned and called as needed—normally for the assault. Smoke can reduce the effectiveness of enemy battlefield

illumination as well as his night vision devices. Indirect HE fire may hide the sound of the BFVs as well as to suppress enemy gunners. Thermal sights work with or without light equally well and should be used by the vehicle element as it fires into the objective. Illumination rounds can be fired to burn on the ground to help orient movement.

c. The commander may decide to attack mounted if enemy fire is ineffective, to maintain momentum against an enemy occupying hastily prepared positions. This allows platoons to close rapidly on the objective, and it conserves the strength of the dismount teams.

d. In a dismounted attack, the platoon moves mounted as close as practical to the objective. Dismount points are determined during the planning process. Actions at the dismount point, equipment needed, and use of BFVs must be planned and rehearsed. The dismount element dismounts and assaults the objective while the fighting vehicle element provides supporting fire. During the assault, the fighting vehicle element leader must closely control the element's fires to ensure enemy is suppressed and to avoid endangering dismounted soldiers. A prearranged signal, such as a pyrotechnic device or code word, to lift or shift fires is crucial in limited visibility operations due to the inability of the crew to clearly distinguish between friendly infantry and enemy. As soon as the objective is seized, the vehicle element moves to the objective area. The platoon should have a prearranged signal, such as a blinking, filtered flashlight, to help the fighting vehicle element locate and join the dismounted element. The platoon leader selects positions on or near the objective for the BFVs and squads, and requires each fire team to provide a vehicle guide to simplify movement into positions.

e. Even though a nonilluminated attack is planned, leaders must plan illumination from the LD to the objective so, if needed, it is available. Once the assault starts, illumination on the objective may help detect targets and enhance command and control.

f. The platoon leader also plans for the use of smoke during the attack. If the enemy fires illumination, the platoon leader can find smoke on known enemy positions or use smoke to screen movement. Smoke also reduces the effectiveness of most of the enemy's night vision devices.

g. The main advantage gained by attacking dismounted and using stealth is surprise. Attacks by stealth can be conducted during any condition of reduced visibility. The concept of a dismounted attack using stealth is to get as close as possible to the enemy's position without a fight; then, before he can react, surprise and overwhelm him. This also allows the dismounted infantry to advance to a position of advantage where it

can support a subsequent attack by tanks from a position of close overwatch during daylight.

h. The mission of the fighting vehicle element is to support the dismount element by fire. In the commander's OPORD, the fighting vehicle element is normally assigned a support-by-fire position, a sector of fire, and a route to the objective. The platoon leader designates a support-by-fire position and a sector of fire for each section. He also specifies how he plans to control their fire. The vehicle element leader positions the BFVs and provides command and control to the mounted element. The platoon leader selects the route for the dismount element and their objective.

i. If vehicle noise will alert the enemy, the BFV moves as close as it can to the overwatch position and halts. From there, an observer or Bradley commander can be sent forward to observe the sector of fire and assist the fighting vehicles when they move into their exact positions.

j. Once the objective is seized, the fighting vehicle element moves quickly to the objective and occupies hull-down positions just as in a daylight attack. The dismount element provides guides to lead the vehicles to their positions.

k. Control measures used for a limited visibility attack are the same as those for an attack during good visibility. However, some adjustments may have to be made.

(1) **Attack position.** An attack position is short of the LD, provides cover and concealment, and permits easy entry and exit. It is used to ensure coordinated effort by the entire force. It may not be used. During limited visibility, it may be closer to the LD and smaller than during good visibility.

(2) **Line of departure.** An LD is designated to coordinate the commitment of attacking units at a specified time, the same as during good visibility.

(3) **Point of departure.** A point of departure is designated, because it is critical all movements be closely coordinated. Squads, section, or platoon may be assigned such a specific point to cross the LD.

(4) **Release point.** Each company commander releases control of his platoons to the platoon leaders at the company RP. RPs are far enough from the objective to allow units to deploy before they reach the probable line of deployment.

(5) **Route.** The company commander normally picks the routes from the company RP to platoon RPs. Platoon leaders pick routes from platoon RPs to the squad RPs.

(6) **Probable line of deployment.** The company commander may designate a PLD. This is the approximate place he plans to have the

dismounted element complete deployment for the assault, if not yet detected. From the PLD, the dismount element begins its assault using fire and movement.

(7) **Objectives.** The company commander assigns each platoon an objective, which is part of the company objective. These are easy-to-identify terrain features.

(8) **Limit of advance.** To keep friendly supporting fires from falling on friendly dismounted troops, leaders may designate a limit of advance. It should be a terrain feature easy to recognize during limited visibility. Assaulting elements do not advance beyond this feature. This allows supporting fires beyond the objective without endangering friendly troops.

l. Wire communications are integrated into the plan. Wire is used from the company release point to the squad release point near the PLD in dismounted attacks. A field phone at each release point allows leaders from company to squad to maintain secure communications before the attack. Wire is dispersed during movement via an MX306, so communication using wire can be maintained throughout the attack.

m. The commander may organize a patrol to guide dismount elements from the attack position to the point of departure on the LD and onto the PLD. Patrols may establish security at the PLD and conduct surveillance of the objective while the dismount elements are moving forward. Patrols should be composed of a fire team from each squad, with the company or company team commander designating the patrol leader.

n. Except for small objectives, a platoon attacks dismounted as a part of a company dismounted operation. Each platoon has a separate, smaller objective or a portion of the company objective. The platoon moves from the assembly area using the formation and movement technique normally specified by the commander. Final coordination is made in the attack position if needed and then platoons move toward the LD. The commander may move the attack force to the LD along a single route under his control or, for short-distance attacks, he may designate separate routes for each platoon. Once across the LD, movement is continuous with the rate of advance slow enough to permit silent movement. The traveling technique with fire teams in column normally is used to ease control and maintain stealth. If the attack is discovered during movement, and elements are close enough to the objective to begin the assault, the dismount element leader (usually the platoon leader) immediately deploys his elements and begins fire and movement.

o. The platoon uses all of its night observation equipment to help control movement and detect enemy positions. This includes two starlight scopes, the Dragon night trackers, and night vision goggles not

needed by the BCs. The BFV may be placed where its thermals can help guide the dismount element to the objective and support by fire once the assault begins.

p. If the attack is not discovered before reaching the PLD, the leader deploys his elements and informs the commander when the squads are fully deployed. On order, they move silently forward. They guide on the base element, using overwatch as much as possible.

q. The platoon assaults the objective on order or when the attack is discovered. As in good visibility, the assault must be aggressive, using cover-to-cover rushes. The assaulting force quickly gains fire superiority by using heavy volume of fire so they can safely move. Tracers can be used to improve accuracy and to help control fires. Soldiers do not assault past the limit of advance.

r. As soon as the objective has been seized, the mounted element platoon leader is informed. Guides are posted to meet the vehicles and lead them into position. The rest of the platoon destroys remaining resistance and prepares for a counterattack.

s. Additional control techniques include—

- Stabilized gun set on specific azimuth.
- Mortar or artillery rounds to orient attacking units.
- Thermal TRPs (either man-made and pre-placed or natural features that stand out using thermals).
- Squad leaders and team leaders use tracers to direct fires.
- Friendly tracer fire to help troops maintain direction.
- Guides.
- Reduced interval.
- Base vehicle on which all others base their speed and direction.
- Luminous tape or markings.
- Rehearsals.

2-67. INFILTRATION

The following considerations and techniques apply to infiltration.

a. Infiltration is done best when visibility is poor, in close terrain, or in areas the enemy does not occupy or cover by direct fire. These conditions allow undetected movement and place friendly forces in a position of advantage over the enemy.

b. A platoon normally infiltrates as part of its company when the company consolidates its dismounted infantry and BFVs for a specific operation. A platoon or squad may infiltrate alone, but this is not a normal occurrence. Movement techniques are based on the likelihood

of enemy contact. BFVs may follow along the infiltration lane at a predetermined time or distance to support the infantry in their assault. A separate axis for BFVs may be used but the risks of detection are greater to do so.

c. An infiltrating element is assigned an infiltration lane. The leader decides whether to move the entire element on a single route. The platoon leader must decide the best use of his BFVs. This decision may be made for him if the commander consolidates his dismounted elements under his control for an infiltration. In this case, all the company's BFVs are normally under the control of the company executive officer or first sergeant.

d. During infiltration, BFVs can be employed in the following ways.

(1) BFVs can overwatch from the LD, or from inappropriate terrain feature, where they can use their thermal sights to help orient or vector the dismounted movement, or they can provide supporting fires if needed. Once the rally point or assault position is reached, or upon initiation of an assault, BFVs can be brought forward to either support by fire from a close overwatch or to remount and continue the mission.

NOTE: BFVs may follow the same axis or use a separate axis based on METT-T. Using the same axis is more secure. The infiltration lane should be well marked, or guides should be used to lead BFVs forward.

(2) If the terrain provides covered and concealed routes for BFVs or if BFV suppressive fire is needed quickly, the BFVs may follow the dismounted platoon at an appropriate interval. That interval may be 50 or 100 meters in close terrain. The platoon leader may use indirect fires to help cover the noise of vehicle movement. However, with careful lane selection, armored vehicles can effectively infiltrate.

c. A platoon can use single or multiple routes to infiltrate.

(1) If a single lane is used, the platoon leader must select a route through the enemy positions and select a rally point. (Figure 2-124.) If multiple routes are used, the platoon leader must choose a lane for each squad, and a rally point where the platoon will link up. The route must avoid enemy positions, have cover and concealment, and ease control and navigation. When deciding to use single or multiple routes, the platoon leader must consider several things. Moving on a single route will—

- Get the element to its rally point faster.
- Ease control.
- Ease navigation.
- Increase the chances of the entire element being detected.

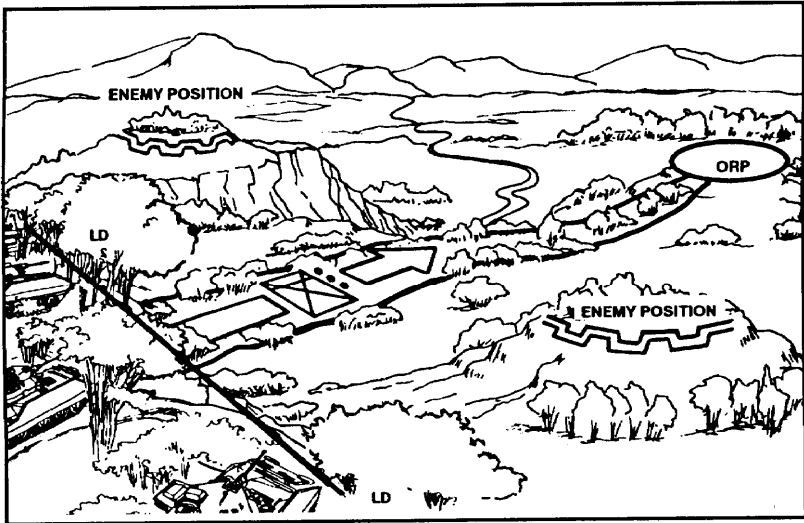

Figure 2-124. Platoon moving on single route.

- (2) Moving on multiple routes (Figure 2-125) will—
- Get the element to its rally point slower.
 - Hinder control.
 - Hinder navigation.
 - Decrease the chances of the entire element being detected.
 - Increase possibility of detection of part of the element.

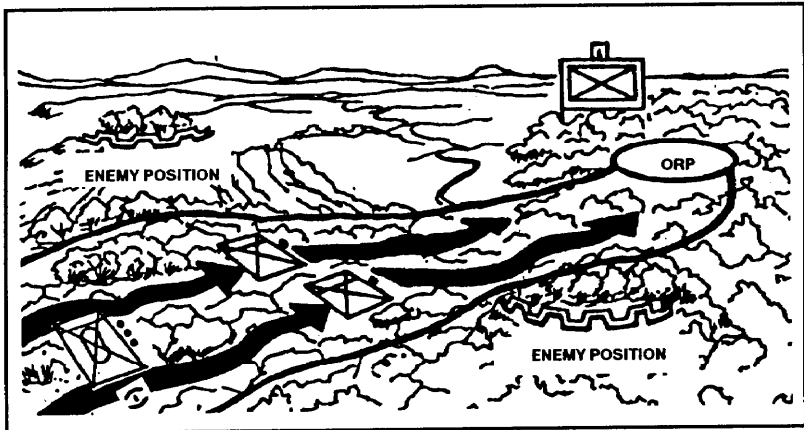

Figure 2-125. Platoon moving on multiple routes.

(a) Rally points are designated along each route where the platoon can—

- Rendezvous with BFVs.
- Reassemble and reorganize if dispersed.
- Halt to reorganize and prepare to continue the mission.

(b) Each rally point should—

- Be easy to find.
- Provide cover and concealment.
- Be defensible in all directions.
- Be located away from likely enemy routes of movement; for example, roads, trails, ridgelines.

(c) Routes should be reconnoitered as much as possible without giving away the plan. This may be possible by map reconnaissance only. Some tentative rally points are chosen based on a map reconnaissance; others are chosen as the element moves along the route. If the element is dispersed by enemy action, its plan should provide for continuing the mission after a set number of men arrive at the rally point or after a specified time. The senior man at the rally point decides how to best continue the mission.

(d) The assault position should be as close as possible to the objective without losing security. It should be large enough so the element can deploy in it. If possible, it should be secured before it is occupied. Leaders may leave from the assault position to reconnoiter the objective. BFVs may—

- Support the dismount element from the LD.
- Move to support by fire position to provide close support once the dismount element has reached the assault position.
- Move along a separate axis to either assault or support the dismounted element in their assault.
- Draw the enemy's attention away from the dismounted assault.

(e) Squads should take only needed equipment. Excess or bulky equipment slows movement and increases the chance of detection.

2-68. LIMITED VISIBILITY DEFENSE

Infantry platoons and squads are often required to conduct defensive operations during limited visibility therefore, these operations should be emphasized during training exercises.

a. Limited visibility conditions refer to darkness, fog, rain, smoke, dust, or any battlefield obscurants that may be employed. These conditions

may require the use of image intensifiers, thermal sights, binoculars, and artificial illumination. Devices (such as image intensifiers and thermal sights) should be used together so the capabilities of one system can offset the disadvantages of the other. During heavy rain, snow, fog, smoke, and dust, the effectiveness of night vision devices is degraded, and increased security measures must be implemented. This includes setting up more OPs, patrols, and remote sensors.

b. Limited visibility conditions afford platoons and squads some concealment from enemy observation and reconnaissance. To maximize the advantages of limited visibility, individual soldiers and leaders consider several factors.

(1) At night, objects may appear distorted. Ranges are difficult to estimate and dark objects appear more distant than light objects. To compensate for scan, off-center viewing techniques are used as outlined in FM 21-75, Chapter 4. On a clear night, the naked eye can distinguish land relief up to 400 meters. With a full moon, the naked eye can spot a moving man about 240 meters away and with binoculars, at 700 meters. Haze, smoke, dust, and fog limit observation farther. Also, at night, sound can be heard farther, but the direction is difficult to determine.

(2) Haze, smoke, and fog may prevent the use of image intensification devices during daylight. The effectiveness of thermal sights is also degraded. Provisions for day limited visibility operations must be made. Range cards are prepared so personnel can cover avenues of approach and obstacles, and shift and mass fires.

(3) Physical and psychological factors must also be considered in limited visibility operations. Darkness may stimulate the imagination, creating a feeling of insecurity that could lead to panic. The sensitivity of the eyes and ears during night differs from day. Soldiers using RSTA devices should rest at least every 30 minutes. To avoid eye fatigue, operators are rotated every hour. Sleep plans should be established and enforced; otherwise, the individual soldier's fighting ability is degraded.

2-69. POSITIONS

When occupying a defensive position during good visibility, the platoon leader must prepare for limited visibility by designating positions for vehicles and crew-served weapons. When possible, vehicles and crew-served weapons should be placed in positions that will preclude repositioning for limited visibility conditions. If repositioning of vehicles and crew-served weapons is necessary, the distance these weapon systems must move are kept to a minimum and moves are made just before dusk. Routes and positions during limited visibility must be designated, and the

movement must be rehearsed during good visibility. Dragon thermal sights have limited capability to fire through smoke and haze.

a. During limited visibility, leaders may have to reposition fire teams and BFVs closer to designated engagement areas. Another reason for repositioning forces is to cover gaps between platoons and companies or alternate avenues of approach created by reduced visibility.

b. Repositioning of forces, if necessary, takes place soon after the beginning of limited visibility conditions. Moves are along previously reconnoitered routes into designated positions.

2-70. COMMAND AND CONTROL IN LIMITED VISIBILITY DEFENSE

A leader's primary task is to coordinate and control the fire and movement of his platoon so he can mass combat power. This is a demanding task when visibility is good and becomes even more demanding when visibility is limited. Poor visibility adds to command and control problems. Leaders must anticipate and overcome every factor that makes it difficult to detect targets, distinguish between friendly and enemy units to prevent fratricide, fire weapons effectively, and navigate. Leaders must also be familiar with the enemy's ability to operate during limited visibility conditions. Against an enemy not equipped with thermal viewers, a well-trained platoon can turn limited visibility conditions to its tactical advantage. Leaders must recognize and exploit this capability when possible. Command and control considerations are the same during limited visibility as during good visibility.

a. In the defense, command and control is vital and more difficult to achieve and maintain during limited visibility conditions. Good command and control begins in the fighting positions. Each fighting position must have the following aids for controlling fires. (Figure 2-126.)

(1) Aiming stakes—used to assist the soldier in firing his weapon on dangerous avenues of approach.

(2) Sector stakes—used on the right and left to define the sector of fire. They also prevent accidental firing into adjacent positions.

b. Range cards, and squad, section, and platoon sector sketches are essential for control. It is through the integration of such control measures that a coordinated defense is possible. Target reference points (TRPs) are especially necessary for the 25-mm and TOW systems due to the difficulty of estimating distances at long range. TRPs are selected out to the maximum ranges of the systems either through a careful map study or by pacing or driving the distance. If tanks are available, their laser range finders or the forward observer's range finder may be used to mark

or verify TRPs. TRPs should be identifiable during limited visibility to the extent of the engagement area or maximum engagement range. A heat source, or thermal marker, should be used. Leaders may use additional control measures, such as tracers, to identify point or area targets and pyrotechnics to control lifting, shifting, or concentrating of fires.

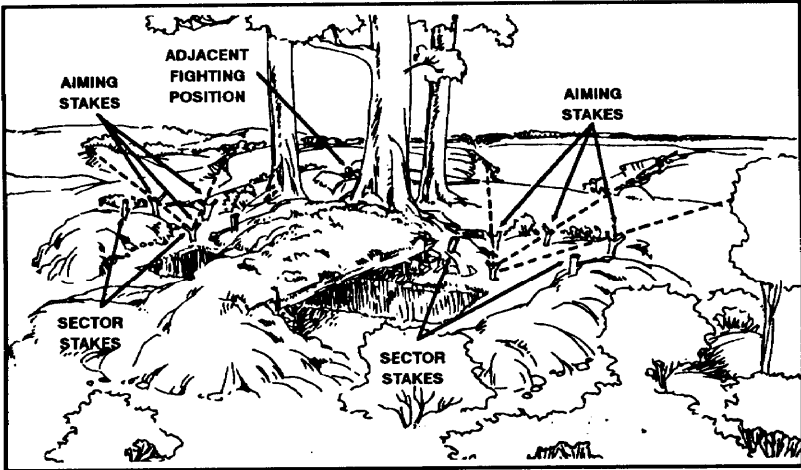

Figure 2-126. Aiming stakes and sector stakes.

2-71. COORDINATION

Leaders must coordinate with adjacent vehicle position and platoons. Coordination includes sectors of fire for crew-served and vehicular weapons systems, repositioning of forces during limited visibility, and security measures necessary for the front and flanks. Lateral communication, mounted and dismounted may facilitate command and control. Fratricide avoidance is a central part of coordination. BFV crews must remain aware of the movement of the infantry to avoid casualties from friendly fires. Also, infantry squads must establish measures to inform BFV crews of their current location.

a. Leaders position RSTA equipment and night vision devices so overlapping fields of observation are established within their sector. Patrols and PEWS cover gaps in observation. Obstacles must also be guarded to prevent enemy reduction.

b. The capabilities of the integrated sight unit must be exploited. This system must be manned and a surveillance plan be implemented to ensure that sectors of observation overlap. Operation of the ISU requires

starting the engine of the Bradley about every two hours to keep the batteries charged. All Bradleys should be started at the same time to prevent the enemy from knowing how many vehicles are on the position. Thermal sights should not be turned off on any vehicle because of the amount of time required to cool down once they are reactivated.

2-72. OCCUPATION OF A DEFENSIVE POSITION

The techniques used to occupy a defensive position during good visibility apply during limited visibility. Placing the dismounted element and BFVs on the same battle position may facilitate command and control but has certain disadvantages:

- Because of differences in weapon ranges, either the BFVs or dismount element is not used to their best advantage.
- The enemy's information gathering is made easier. Once he finds the BFVs, he knows where the infantry is located, which eliminates surprise.

a. A defensive position should be reconnoitered during good visibility. Both the reconnaissance and occupation must be done with stealth under enforced light and noise discipline. Techniques used by a quartering party are appropriate. The security element that accompanies the platoon leader remains to maintain observation on the position and acts as guides when the platoon main body arrives.

b. During the reconnaissance, the platoon leader—

- (1) Ensures that no enemy forces occupy the proposed battle position.
- (2) Identifies enemy avenues of approach (mounted and dismounted) and potential enemy overwatch positions.
 - (a) Dismounted infantry orients on dismounted avenues of approach.
 - (b) BFVs are placed to best cover mounted avenues of approach; supplemental positions are determined so BFVs can cover the dismounted avenue.
 - (c) Positions for BFVs and infantry should be marked for easier occupation.
 - (3) Chooses engagement areas if not assigned by the commander.
 - (4) Chooses primary, alternate, and supplementary positions for squads and fighting vehicles.
 - (5) Identifies dead space and formulates a plan to cover it.
 - (6) Chooses locations for observation posts and the command post.
 - (7) Confirms location of adjacent platoons and companies.
 - (8) Selects target reference points, sectors of fire, and other control measures.

- (9) Chooses routes into and out of positions.
- (10) Conducts NBC reconnaissance.

c. A reconnaissance conducted during limited visibility must accomplish the same objectives. Because of the limited range of observation, the leader's task must be accomplished with great care. He must ensure his reconnaissance is done with a RSTA device of similar capabilities of the weapon systems.

NOTE: If BFVs and dismounted infantry are on separate battle positions both elements use all available RSTA assets. For example: The dismount element uses Dragon nightsights, thermal sights, hand-held thermal sights, light intensification devices, and binoculars. The BFVs have a plan, based on the enemy situation, to maintain a specific number of thermal sights operating at all times as well as light intensifiers and binoculars. At least one of the BFVs must either have its thermal off or local security posted to listen for enemy activity. (The BFVs thermal and turret noise sometimes prevent hearing a stealthy enemy.)

d. Based on available time, the platoon leader goes forward, conducts his reconnaissance, returns to the platoon position, and brings forward either—

- (1) The mounted section leaders and squad leaders.
- (2) Mounted section leaders, platoon sergeant, and squad leaders.

He should assign squad and fighting vehicle positions, sectors of fire, TRPs, and engagement areas. Leaders then return to the platoon position and issue orders for the occupation and preparation of forward positions. The platoon then moves forward.

e. If there is not enough time, the platoon leader may take his leaders forward during the initial reconnaissance, or bring the entire platoon forward to an assembly area near the defensive position, and then conduct his reconnaissance with key leaders.

f. As platoon members occupy defensive positions, they accomplish the work priorities as described in Chapter 5. The platoon leader or platoon sergeant must verify that interlocking fields of fire and mutual support are achieved. The platoon leader then goes forward to examine his positions from the enemy's perspective. 

g. The platoon leader must carefully consider the method of employing the dismount element and the BFVs. Whether to fight both elements from different battle positions or the same battle position must be closely examined. During limited visibility, the occupation of battle positions and controlling fires is simplified if both elements are on the same battle position.

h. All activities normally associated with the occupation of defensive positions during good visibility are done during limited visibility. Techniques may change to compensate for limited visibility conditions such as using night vision devices to establish sectors of fire. Noise and light discipline must be strictly enforced. Face-to-face coordination with adjacent platoons must be conducted and sectors of fire coordinated. Coordination should effectively tie in overlapping sectors of fire and observation with weapon systems and night vision devices. When good visibility returns, defensive positions are adjusted as necessary. Detailed schedules are developed to ensure the priorities are accomplished while maintaining thermal surveillance on a 24-hour basis.

CHAPTER 3

BATTLE DRILLS AND CREW DRILLS

Mechanized infantry battle and crew drills describe how platoons and squads apply immediate action and fire and maneuver to commonly encountered situations and equipment malfunctions. They require leaders to make decisions rapidly and to issue brief oral orders quickly. A platoon's ability to accomplish its mission often depends on soldiers, leaders, and squads and sections executing key actions quickly. All soldiers and their leaders must know their immediate reaction to enemy contact and equipment malfunction as well as follow-up actions. Drills are limited to situations requiring instantaneous response; therefore, soldiers must execute drills instinctively. This results from continual practice. Drills provide platoons with standard procedures essential for building strength and aggressiveness. They identify key actions that leaders and soldiers must perform quickly. They provide for a smooth transition from one activity to another; for example, from movement to offensive action to defensive action. They provide standardized actions that link soldier and collective tasks at platoon level and below. (Soldiers perform individual tasks to CTT or SDT standard.) They must be understood by each individual and leader, and continually practiced by the platoon. The format for drills discussed in this chapter includes the title, the SITUATION that would cue the platoon or the leader into initiating the drill, the REQUIRED ACTIONS in sequence, and supporting illustrations. Where applicable, drills are cross-referenced with material in other chapters, other drills, or both. Battle drills are in Section I and crew drills are in Section II. (See ARTEP 7-7J-DRILL for the task, conditions, and standards for drill training.)

Section I BATTLE DRILLS

A *battle drill* is a collective action executed by platoon or smaller element without applying a *deliberate* decision-making process. The action is vital to success in combat or critical to preserving life. The drill is initiated on a cue, such as an enemy action or simple leader's order, and is a trained response to the given stimulus. It requires minimal leader orders to accomplish and is standard throughout like units.

Battle Drill 1
PLATOON ATTACK
(DISMOUNTED)

SITUATION: The platoon is moving as part of a larger force conducting a movement to contact or a hasty or deliberate attack.

REQUIRED ACTIONS: (Figure 3-1, page 3-8.)

STEP 1. Action on Enemy Contact.

a. **The platoon initiates contact.** The platoon leader directs when and how his base-of-fire element initiates contact with the enemy to establish a base of fire. This element must be in position and briefed before it initiates contact. If the platoon has not been detected, Steps 1 and 2 consist of positioning the base-of-fire element and identifying the enemy's positions.

b. **The enemy initiates contact.** If the enemy initiates contact, the platoon takes the following actions:

(1) The squad in contact reacts to contact (Battle Drill 2). It attempts to achieve suppressive fires with one fire team, then maneuvers the other team to attack the enemy in the flank.

(2) The platoon leader, his RATELO, the platoon FO, and the squad leader of the other squad move forward to link up with the squad leader of the squad in contact.

(3) The platoon sergeant repositions the BFVs as necessary to provide observation and supporting fires against the enemy.

(4) The platoon leader reports contact and assesses the situation. He follows the success of the squad's flank attack by leading the trail squad along the covered and concealed route taken by the assaulting fire team of the squad in contact.

(5) If the squad in contact cannot achieve suppressive fire, the squad leader reports to the platoon leader.

(a) The squad in contact establishes a base of fire. The squad leader deploys his squad to provide effective, sustained fires on the enemy position. The squad leader reports his final position to the platoon leader.

(b) The remaining squad (not in contact) takes up covered and concealed positions in place and observes to the flanks and rear of the platoon.

(c) The platoon leader moves forward with his RATELO, the platoon FO, and the other squad leader.

STEP 2. Locate the Enemy.

- a. The squad leader of the squad in contact reports the enemy size and location, and any other information to the platoon leader. The platoon leader completes the squad leader's assessment of the situation.
- b. The squad continues to engage the enemy's position.
- c. The platoon leader directs the platoon sergeant to reposition the BFVs as necessary to observe and provide supporting fires against the enemy.

STEP 3. Suppress the Enemy.

a. The platoon leader determines if the BFVs and squad in contact can gain suppressive fire against the enemy, based on the *volume* and *accuracy* of the enemy fire and the ability of the BFVs to suppress the enemy.

(1) If YES, he directs the BFVs and the squad in contact to continue suppressing the enemy.

(a) The BFVs and the squad in contact destroys or suppresses enemy weapons that are firing most effectively against them, including vehicles and crew-served weapons.

(b) In addition, the squad in contact places screening smoke (M203) to prevent the enemy from seeing the maneuver element.

(2) If NO, the platoon leader deploys the other squad to suppress the enemy position.

(3) The squad not in contact provides suppressive fires from its overwatch position or repositions to observe and provide suppressive fires against the enemy.

b. The platoon leader again determines if the platoon can gain suppressive fires against the enemy.

(1) If YES, he continues to suppress the enemy with the two squads and the BFVs. The platoon FO calls for and adjusts fires based on the platoon leader's directions. (The platoon leader does not wait for indirect fires before continuing with his actions.)

(2) If still NO, the platoon leader reports the situation to the company commander. Normally, the platoon will become the base-of-fire element for the company. The platoon continues to suppress or fix the enemy with direct and indirect fire, and responds to orders from the company commander.

STEP 4. Attack.

If the BFVs and the squad in contact can suppress the enemy, the platoon leader determines if the remaining squad not in contact can maneuver. He makes the following assessment.

- Location of enemy positions and obstacles.
- Size of enemy force. (The number of enemy automatic weapons, the presence of any vehicles, and the use of indirect fires are indicators of enemy strength.)
- Vulnerable flank.
- Covered and concealed flanking route to the enemy position.

a. If YES, the platoon leader maneuvers the squad not in contact into the assault:

(1) Once the platoon leader has ensured that the base-of-fire element is in position and providing suppressive fires, he leads or directs the assaulting squad, by the flanking route, to the enemy position.

(2) Once in position, the platoon leader gives the prearranged signal for the base-of-fire element to lift or shift direct fires to the opposite flank of the enemy position. (The assault squad must pickup and maintain effective fires throughout the assault. Handover of responsibility for direct fires from the base-of-fire element to the assault element is critical to prevent fratricide.)

(3) The platoon FO shifts indirect fires to isolate the enemy position.

(4) The assaulting squad fights through enemy positions using fire and maneuver. The platoon leader controls the movement of his squad. He assigns specific objectives for each team and designates the main effort or base maneuver team. (The base-of-fire element must be able to identify the near flank of the assaulting squad.)

(5) In the assault, the squad leader determines the way in which he will move the teams of his squad based on the volume and accuracy of enemy fire against his squad and the amount of cover afforded by the terrain. (Figure 3-2.) In all cases, each soldier uses individual movement techniques as appropriate.

(a) The squad leader designates one fire team to support the movement of the other team.

(b) The squad leader designates a distance or direction for the team to move. He accompanies one of the fire teams. (See Figure 3-2, page 3-10.)

(c) Soldiers must maintain contact with team members and leaders.

(d) Buddy teams time their firing and reloading in order to sustain their rate of fire. Teams are—

- Fire Team A, Buddy Teams: Team leader and automatic rifleman, grenadier (M203) and antiarmor specialist.

- Fire Team B, Buddy Teams: Team leader and automatic rifleman, automatic rifleman and antiarmor specialist.

(e) The moving fire team proceeds to the next covered position. Teams use the wedge formation when assaulting. Soldiers move in rushes or by crawling.

(f) The squad leader directs the next team to move.

(g) If necessary, the team leader directs soldiers to bound forward as individuals within buddy teams. Soldiers coordinate their movement and fires with their buddies. They maintain contact with their team leader.

(h) Soldiers fire from covered positions. They select the next covered position before moving. They either rush forward (no more than 5 seconds), or use high or low crawl techniques based on terrain and enemy fires.

b. If NO, or the assaulting squad cannot continue to move, the platoon leader deploys the squads to suppress the enemy and reports to the company commander. The platoon continues suppressing enemy positions and responds to the orders of the company commander.

STEP 5. Consolidate and Reorganize.

a. **Consolidate.** Once the platoon has seized the enemy position, the platoon leader establishes local security. (The platoon must prepare to defeat an enemy counterattack. The platoon is most vulnerable at the conclusion of the assault.)

(1) The platoon leader signals for the base-of-fire element to move up into designated positions.

(2) The platoon leader assigns sectors of fire for each BFV and squad.

(3) The platoon leader positions BFVs and key weapons to cover the most dangerous avenue of approach.

(4) Soldiers take up hasty defensive positions.

(5) The platoon leader and his FO develop an initial fire support plan.

(6) The squads place out OPs to warn of enemy counterattacks.

b. Reorganize.

(1) The platoon performs the following tasks (only after it completes consolidation on the objective):

(a) Reestablish the chain of command.

(b) Treat casualties and evacuate wounded.

(c) Man crew-served weapons first.

(d) Redistribute and resupply ammunition.

(e) Redistribute critical equipment (radios, NBC, NVDs).

- (f) Coordinate for ammunition and resupply (platoon sergeant).
 - (g) Search, silence, segregate, safeguard, and speed EPWs to collection points.
 - (h) Collect and report enemy information and materiel.
 - (i) Fill vacancies in key positions.
- (2) Squad and section leaders provide ammunition, casualty, and equipment (ACE) reports to the platoon sergeant. (Bradley commanders additionally provide fuel status.)
- (3) The platoon sergeant consolidates ACE reports, reviews them with the platoon leader, and gives them to the first sergeant (or XO).
- (4) The platoon continues the mission after receiving guidance from the company commander. The company follows the success of the platoon's flanking attack.

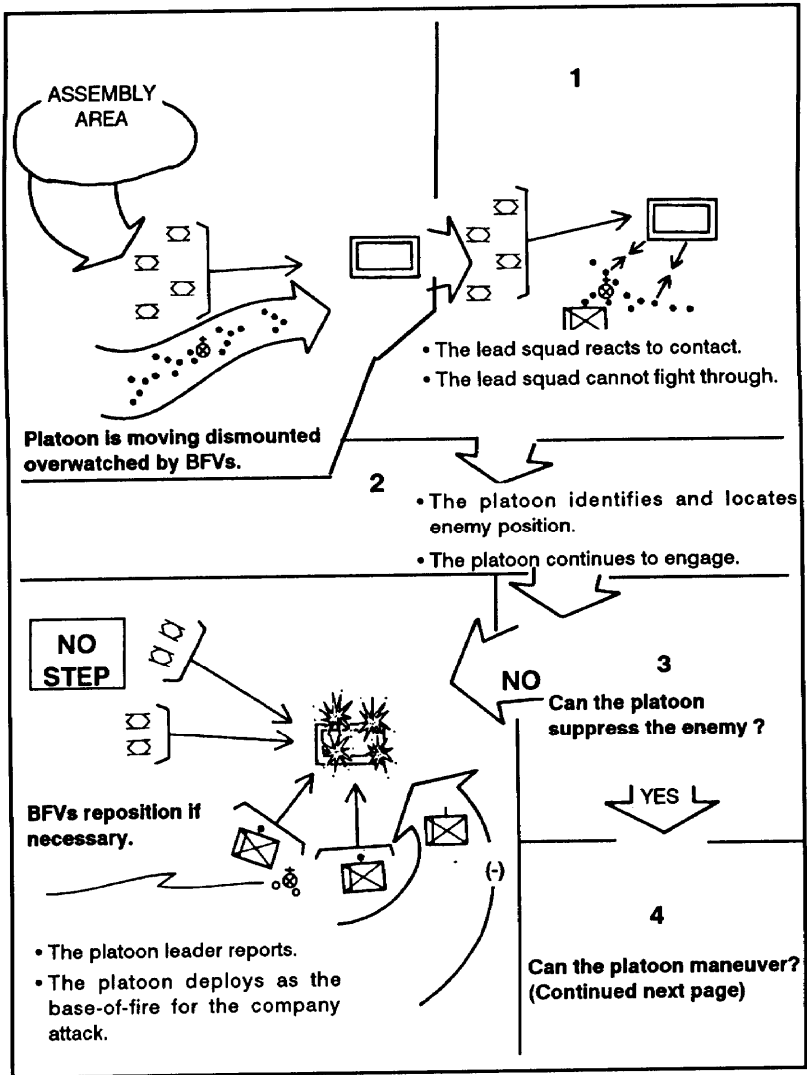

Figure 3-1. Platoon attack (dismounted).

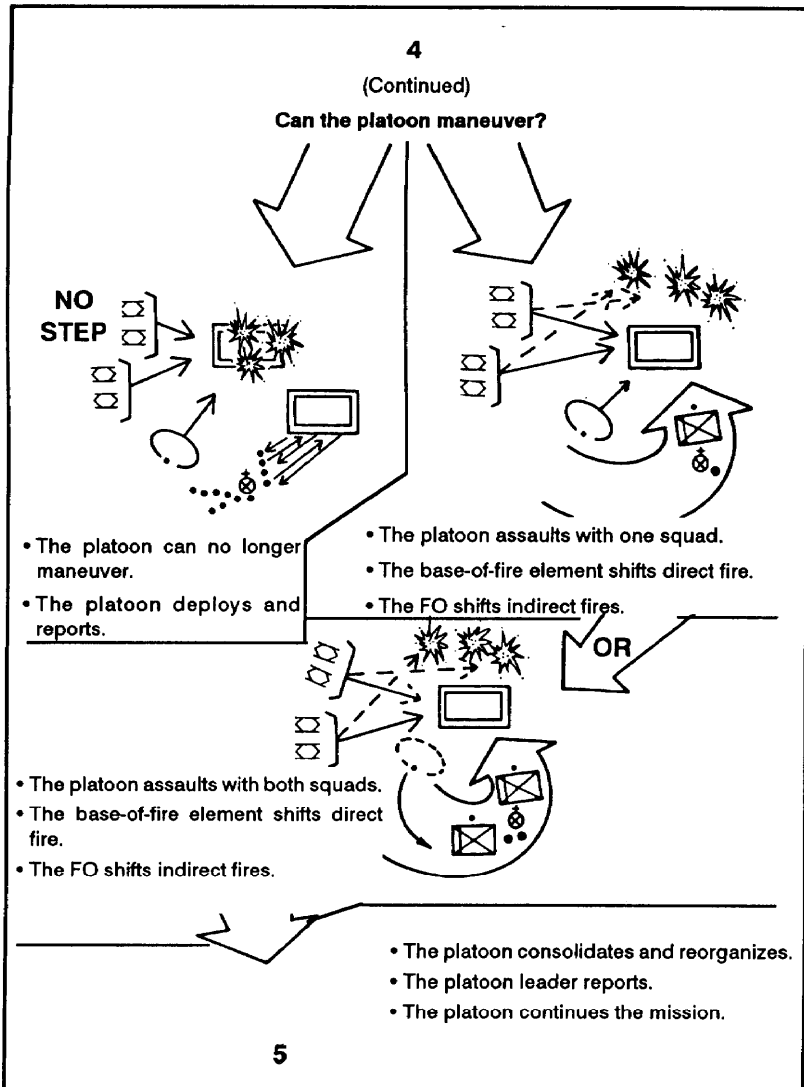

Figure 3-1. Platoon attack (dismounted) (continued).

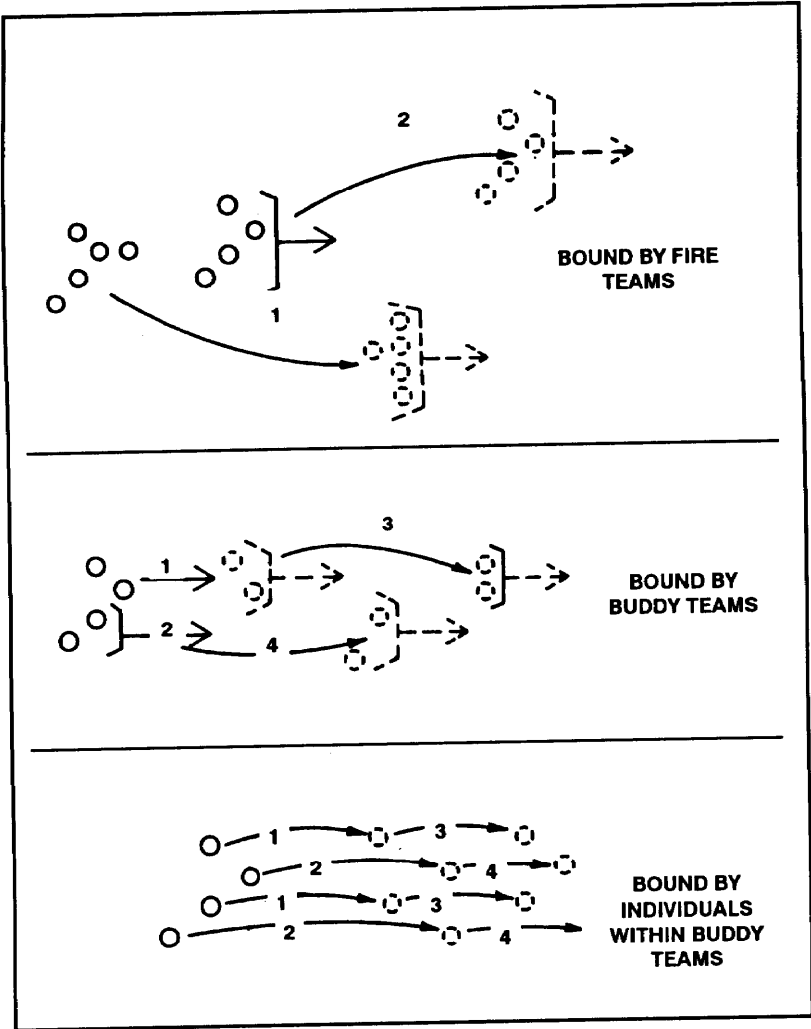

Figure 3-2. Squad and fire team fire and movement in the assault.

Battle Drill 1A
PLATOON ATTACK
(MOUNTED)

SITUATION: The platoon is moving as part of a larger force conducting a movement to contact or a hasty attack.

REQUIRED ACTIONS: (Figure 3-3, page 3-16):

STEP 1. Action on Enemy Contact.

a. **The platoon initiates contact:** The platoon leader directs when and how his base-of-fire element initiates contact with the enemy to establish a base of fire. This element must be briefed before it initiates contact. If the platoon has not been detected, the platoon performs Steps 1 and 2, which consist of positioning the supporting element and identifying the enemy's position.

b. **The enemy initiates contact:** The section in contact reacts to contact (Battle Drill 2A). The section in contact returns fire on the move and moves to covered and concealed positions. The squad dismounts to provide local security or add to the suppressive fires against the enemy.

c. The section not in contact takes up covered and concealed positions and orients its weapons on the enemy.

d. The platoon leader reports contact and assesses the situation.

STEP 2. Locate the Enemy.

a. The section leader of the section in contact (normally the platoon leader or the platoon sergeant) reports the enemy size and location, and any other information. The platoon leader completes the section leader's assessment of the situation.

b. The section in contact continues to engage the enemy's position.

STEP 3. Suppress the Enemy.

a. The platoon leader determines if the section in contact can suppress the enemy based on the *volume* and *accuracy* of the enemy fire.

b. If YES, he directs the section and squad to continue suppressing the enemy.

(1) The BFVs destroy or suppress enemy weapons that are firing most effectively against them, including vehicles and crew-served weapons.

(2) The platoon leader or FO calls for and adjusts, indirect fires (including smoke) to suppress and isolate the enemy position.

c. If NO, he deploys the other section to suppress the enemy position.

(1) The section not in contact provides supporting fires from its overwatch position.

(2) The section not in contact repositions to observe and provide supporting fires against the enemy.

(3) The squad dismounts to provide local security or add suppressive fires against the enemy.

d. The platoon leader again determines if the platoon can gain suppressive fire over the enemy.

e. If YES, he continues to suppress the enemy with the BFVs.

f. The platoon FO calls for and adjusts fires based on the platoon leader's directions. (The platoon leader does not wait for indirect fires before continuing with his actions.)

g. If still NO, the platoon leader reports the situation to the company commander. Normally the platoon will become the base-of-fire element for the company. The platoon continues to suppress or fix the enemy with direct and indirect fire, and responds to orders from the company commander.

STEP 4. Attack.

a. If the section in contact can suppress the enemy, the platoon leader determines if the section not in contact can maneuver. He makes the following assessment:

(1) Location of enemy position(s) and obstacles.

(2) Size of enemy force engaging the section. (The number of enemy automatic weapons, vehicles, and employment of indirect fires.) (The platoon leader must assess the type of enemy resistance.)

(a) Light resistance is resistance from an enemy squad-sized element or smaller that is not producing friendly casualties. The enemy force is equipped with or without an armored vehicle, in a hasty fighting position with no obstacles, and primarily using hand-held antiarmor weapons.

(b) Medium resistance is resistance from an enemy squad- to platoon-sized element that is producing light friendly casualties. The enemy defense is organized around the best defensible terrain with combined arms assets integrated.

(c) Heavy resistance fire is resistance from an enemy platoon-sized element or larger that is producing heavy friendly casualties. The enemy is defending a stronghold with combined arms assets.

(3) Vulnerable flank.

(4) Covered and concealed flanking route to the enemy position.

b. If YES, the platoon leader maneuvers the section not in contact into the assault.

(1) Once the platoon leader has ensured that the base-of-fire section is in position and providing supporting fires, he leads or directs the assaulting section by the flanking route onto the enemy position.

(2) Once in position, the section leader gives the prearranged signal for the base-of-fire section to lift or shift direct fires to the opposite flank of the enemy position. The assaulting section must pickup and maintain suppressive fire throughout the assault. Hand over of responsibility for direct fires from the base-of-fire section to the assaulting section is critical to prevent fratricide from occurring.

(3) The platoon leader ensures that indirect fires are shifted to isolate the enemy position.

(4) The assaulting section fights through enemy positions to the far side. Then the squad dismounts to clear and secure the position using fire and maneuver.

(a) The squad leader determines the way in which he will move the elements of his squad based on the *volume* and *accuracy* of enemy fire against his squad and the amount of cover afforded by terrain. In all cases, each soldier uses individual movement techniques as appropriate.

(b) The squad leader designates one fire team to support the movement of the other fire team.

(c) The squad leader designates a distance or direction for the team to move. He accompanies one of the fire teams.

(d) Soldiers maintain contact with team members and leaders.

(e) Buddy teams time their firing and reloading in order to sustain their rate of fire.

(f) The moving fire team proceeds to the next position.

(g) Soldiers move in rushes or by crawling. (Normally, soldiers place weapons on SAFE before moving. However, they may elect to fire as they rush.)

(h) The squad leader directs the next team to move.

(i) If necessary, the team leader directs soldiers to bound forward as individuals within buddy teams. Soldiers coordinate their movement and fires with each other within the buddy team. They maintain contact with their team leader.

(j) Soldiers fire from covered positions. They select the next covered position before moving. They either rush forward (no more than 5 seconds), or use high or low crawl techniques based on terrain and enemy fires.

(k) Fire team leaders maintain contact with the squad leader and pass signals to team members.

(5) The BFVs of the assaulting section continue to engage and destroy enemy vehicles and any soldiers attempting to withdraw

or reinforce. (The base-of-fire section must be able to identify the near flank of the assaulting section and its squad.)

c. If NO, or the assaulting section cannot continue to move, the platoon leader deploys the sections to suppress the enemy and reports to the company commander. The platoon continues suppressing enemy positions and responds to the orders of the company commander.

STEP 5. Consolidate and Reorganize.

a. The platoon consolidates once it has seized the enemy position and the platoon leader has established local security. (The platoon must prepare to defeat any enemy counterattack. At the conclusion of the assault, the platoon is most vulnerable.)

(1) The platoon leader signals for the base-of-fire section to move up into a designated position.

(2) The platoon leader assigns sectors of fire for each BFV and squad.

(3) The platoon leader positions BFVs and key weapons to cover the most dangerous avenues of approach.

(4) Soldiers take up hasty defensive positions.

(5) The platoon leader and his FO develop an initial fire support plan.

(6) The squads place out OPs to warn of enemy counterattacks.

b. The platoon reorganizes to perform the following tasks (only after it has completed consolidation on the objective).

(1) Reestablish the chain of command.

(2) Treat casualties and evacuate wounded.

(3) Man crew-served weapons first.

(4) Redistribute and resupply ammunition.

(5) Redistribute critical equipment (radios, NBC, NVDs).

(6) Coordinate for resupply (platoon sergeant).

(7) Search, silence, segregate, safeguard, and speed EPWs to collection points.

(8) Collect and report enemy information and materiel.

c. Squad or section leaders provide ammunition, casualty, and equipment (ACE) reports to the platoon sergeant). (Bradley commanders additionally provide fuel status.)

d. The platoon sergeant consolidates the ACE reports, reviews his ACE report with the platoon leader, and passes it to the first sergeant (or XO).

e. The platoon continues the mission after receiving guidance from the company commander. The company follows the success of the section's flanking attack.

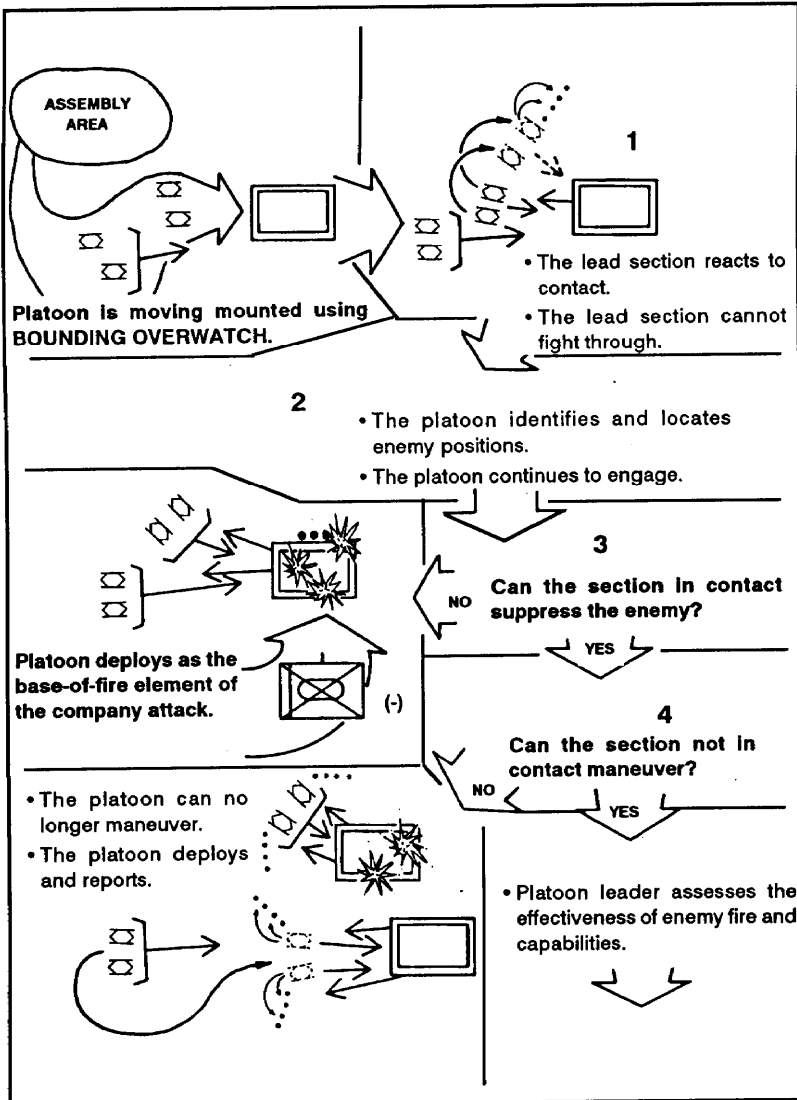

Figure 3-3. Platoon attack (mounted).

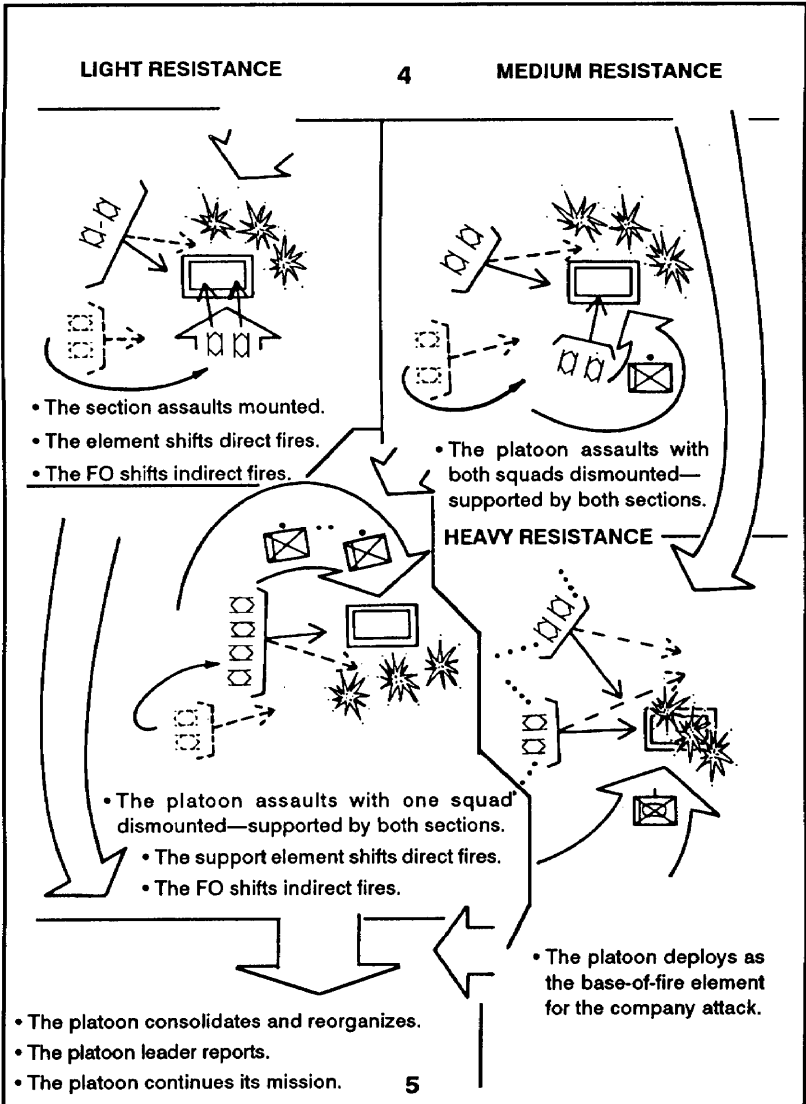

Figure 3-3. Platoon attacks (mounted) (continued)

Battle Drill 2
REACT TO CONTACT (PLATOON OR SQUAD)
(DISMOUNTED)

SITUATION: The platoon or squad (dismounted element) receives fires from enemy individual or crew-served weapons. The dismounted element is operating within the supporting range of the BFVs

REQUIRED ACTIONS: (Figure 3-4.)

1. Soldiers immediately assume the nearest covered positions and return fire in the direction of contact.
2. Squad or team leaders locate and engage known or suspected enemy positions with well-aimed fire and pass information to the squad or platoon leader. The platoon leader reports contact to the company commander.
3. Fire team leaders control fire using standard fire commands (initial and supplemental) containing the elements of alert, direction, description of target, range, method of fire (manipulation and rate of fire), and command to commence firing.
4. Soldiers maintain contact (visual or oral) with the soldiers on their left and right.
5. Soldiers maintain contact with their team leaders and report the location of enemy positions.
6. Leaders (visually or orally) check the status of their personnel.
7. The squad or team leaders maintain visual contact with the platoon or squad leader.
8. The team leader leads his team by example: "Follow me; do as I do."
9. Leaders relay all commands and signals from the platoon chain of command.
10. The platoon sergeant positions the BFVs as necessary to observe and to provide supporting fires.

NOTE: Once the platoon has executed the React to Contact drill, the platoon leader makes a quick assessment of the situation (for example, enemy size, location). He decides on a course of action (Battle Drill 1, Platoon Attack (Dismounted) or Battle Drill 3, Break Contact (Dismounted)). The platoon leader reports the situation to the company commander.

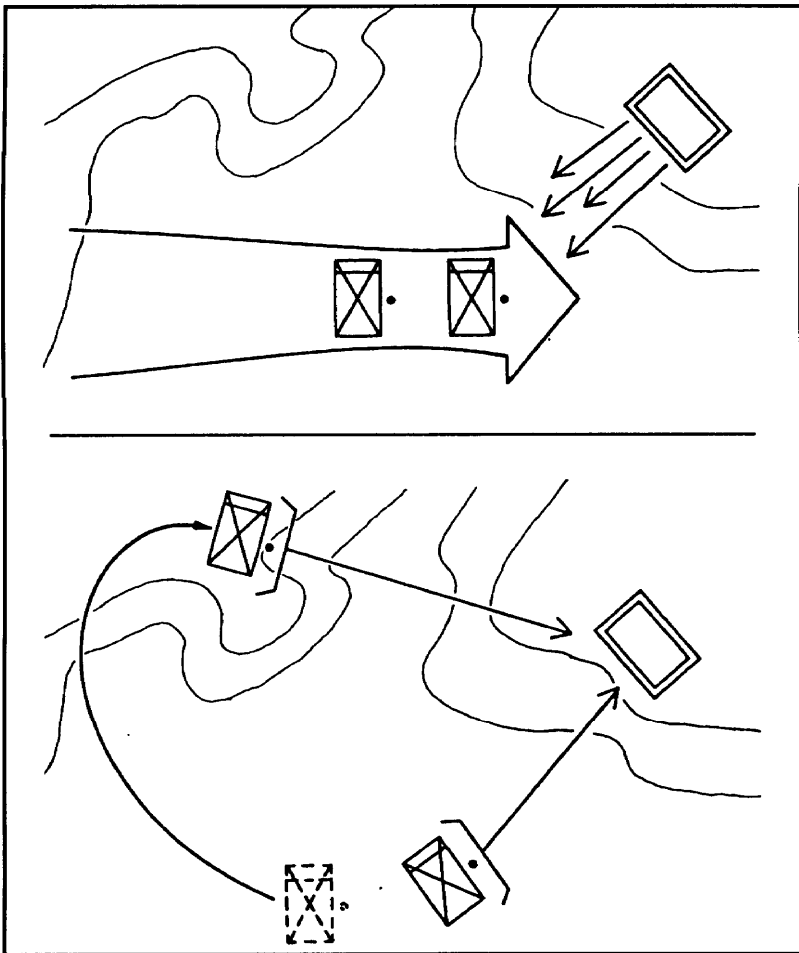

Figure 3-4. React to contact (dismounted).

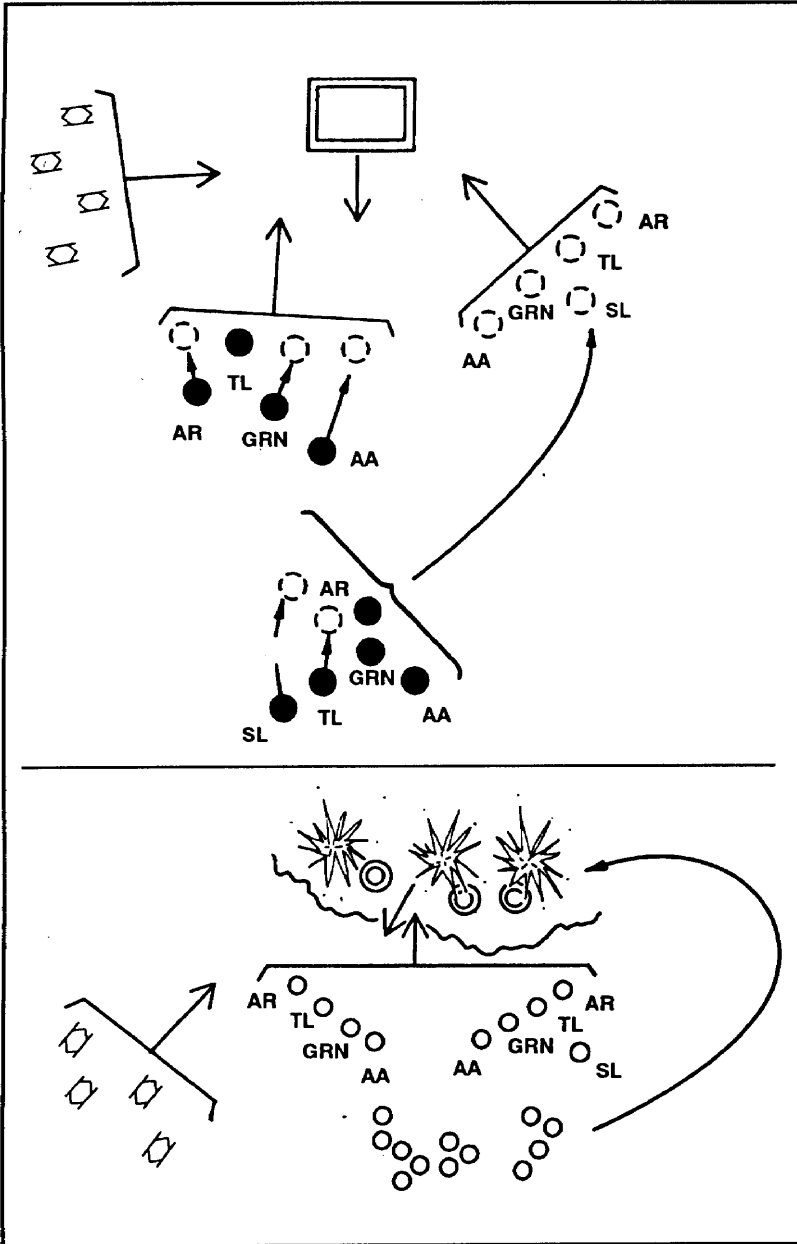

Figure 3-4. React to contact (dismounted) (continued).

Battle Drill 2A
REACT TO CONTACT (SECTION OR PLATOON)
(MOUNTED)

SITUATION: While mounted, the platoon receives fires from enemy individual or crew-served weapons (including light antiarmor weapons).

REQUIRED ACTIONS: (Figure 3-5, page 3-22.)

1. Vehicles of the section in contact immediately return fire in the direction of contact while moving out of the beaten zone. The section leader of the section in contact (if not the platoon leader) reports contact to the platoon leader.

2. All vehicles move to the nearest covered and concealed positions.

3. Upon reaching the covered and concealed position, the section in contact continues to engage the enemy with well-aimed fire using precision or battlesight fire command. The squad dismounts to provide local security and or add its suppressive fires against the enemy position.

4. Vehicles of the section not in contact orient their weapons in the direction of the enemy.

5. The platoon leader or platoon sergeant reports contact to the company commander.

NOTE: Once the platoon has executed the React to Contact drill, the platoon leader makes a quick assessment of the situation (for example, enemy size, location). He decides on a course of action (Battle Drill 1, Platoon Attack (Dismounted); Battle Drill 1A, Platoon Attack (Mounted)). The platoon leader may elect to bypass, if permitted by the company commander. The platoon leader reports the situation to the company commander.

6. Bradley commanders maintain contact with each other (wingman concept).

7. Bradley commanders maintain contact with the platoon leader.

8. Bradley commanders relay all commands to mounted infantry teams.

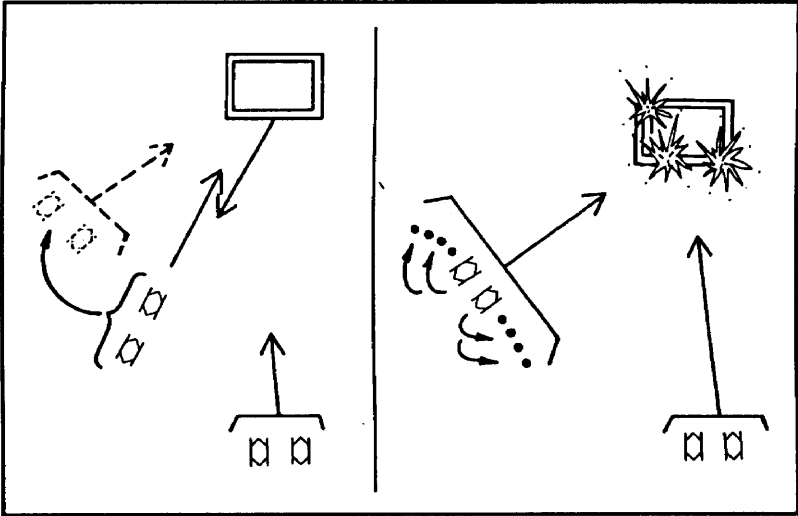

Figure 3-5. React to contact (mounted).

Battle Drill 3

BREAK CONTACT (PLATOON OR SQUAD)(DISMOUNTED)

SITUATION: The platoon or squad (dismounted element) is under enemy fire and must break contact. The dismounted element is operating within supporting range of the BFVs.

REQUIRED ACTIONS: (Figure 3-6, page 3-24.)

1. The platoon leader gives the order to break contact.
2. The platoon leader directs the BFVs to support the disengagement of the dismounted element. (If the BFVs cannot support the disengagement of the dismounted element, the platoon leader directs one squad or fire team to suppress by fire to support the disengagement of the remainder of the element.
3. The platoon or squad leader orders a distance and direction, a terrain feature, or the last objective rally point for the movement of the first squad or fire team.
4. The base of fire BFVs or squad or fire team) increases the rate of fire to suppress the enemy.
5. The maneuver element moves to assume the overwatch position. The maneuver element uses fragmentation, concussion, and smoke grenades to mask its movement.
6. The maneuver element takes up the designated position and engages the enemy position.
7. The platoon leader directs the initial base-of-fire element BFVs or squad or fire team) to move to its next location. (Based on the terrain and the volume and accuracy of the enemy's fire, the maneuver squad or fire team may need to use fire and movement techniques.)
8. The platoon or squad continues to bound away from the enemy until (the platoon or squad must continue to suppress the enemy as it breaks contact)—
 - It breaks all contact.
 - It passes through a higher level base-of-fire position.
 - Its squads or fire teams are in the assigned position to conduct the next mission.
9. In the absence of a leader's instructions, the platoon or squad moves to the last designated rally point.

10. The platoon leader directs the BFVs to move to a rally point and link up with the dismounted element.

11. Section or squad leaders account for soldiers, report, reorganize as necessary and continue the mission.

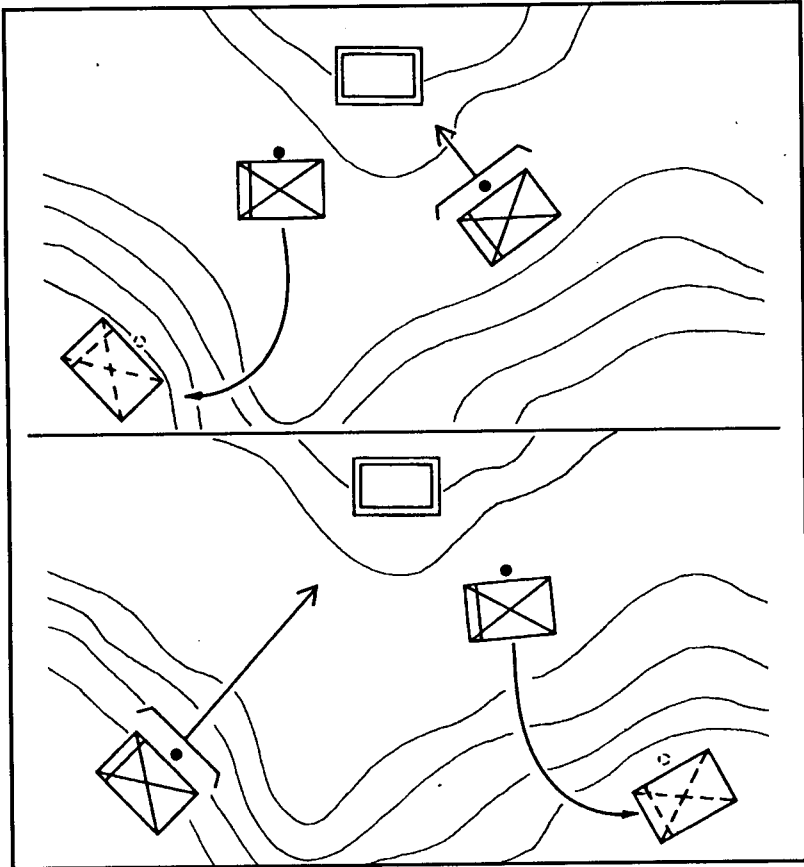

Figure 3-6. Break contact (dismounted).

12. The platoon leader reports the situation to the company commander.

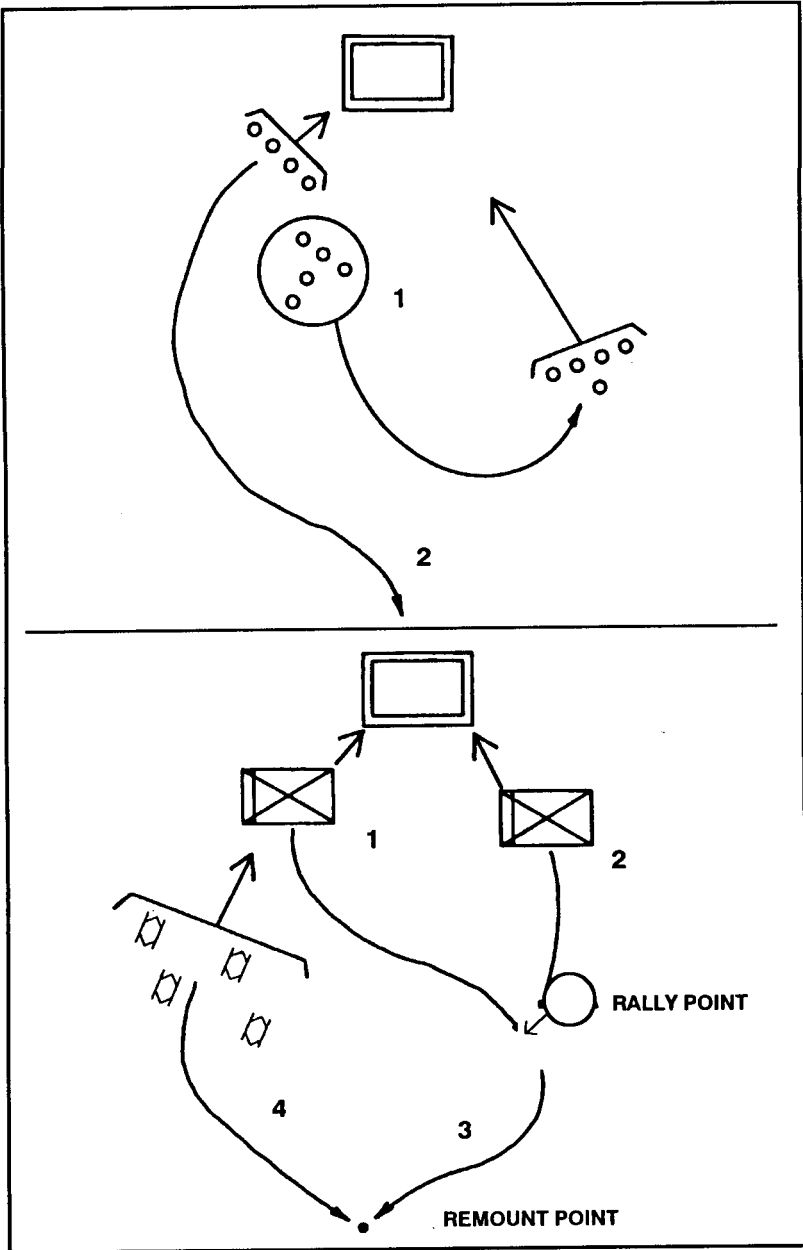

Figure 3-6. Break contact (dismounted) (continued).

Battle Drill 3A
BREAK CONTACT (SECTION OR PLATOON)
(MOUNTED)

SITUATION: The platoon is mounted (except for security elements). It is under enemy fire and must break contact.

REQUIRED ACTIONS: (Figure 3-7.)

1. The platoon leader gives the order to break contact.
2. The platoon leader directs one section to be the base-of-fire element to support the disengagement of the other section.
3. The platoon leader orders a distance and direction, a terrain feature, or last objective rally point for the moving section.
4. The base-of-fire section continues to engage the enemy. It attempts to gain suppressive fire long enough to support the bound of the moving element. (The platoon uses all available direct and indirect fires, including smoke to assist in disengaging.) The section leader controls fires using standard fire commands containing the alert, direction, description of target, range, method of fire, and command to commence firing.
5. The moving section's security element remounts.
6. The moving section continues to fire while moving to an overwatch position and continues to provide suppressive fires. Firing port weapons are manned and ready to fire.
7. The platoon leader directs the supporting section to move to its next location.
8. The platoon continues to bound away from the enemy until The platoon must continue to suppress the enemy as it breaks contact)—
 - a. It breaks all contact.
 - b. It passes through a higher level base-of-fire position.
 - c. Its sections are in the assigned position to conduct the next mission.
9. In the absence of a leader's instructions, the platoon moves to the last designated rally point.
10. Section or squad leaders account for soldiers, report, reorganize as necessary, and continue the mission.
11. The platoon leader reports the situation to the company commander.

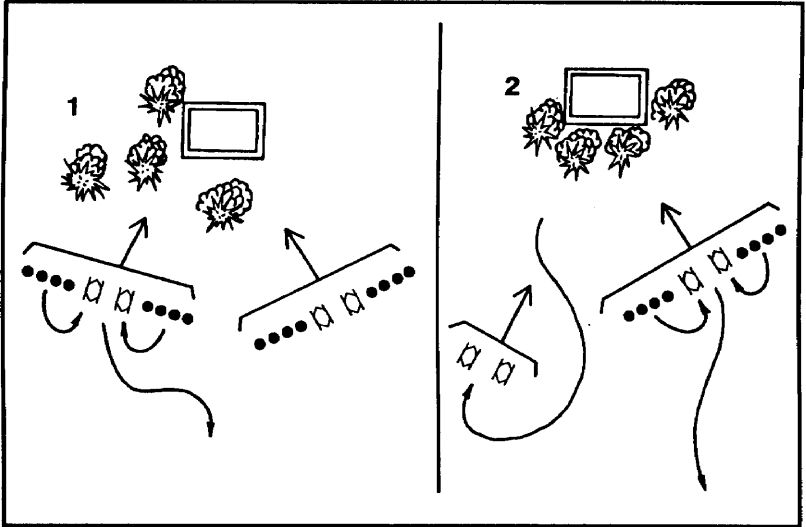

Figure 3-7. Break contact (mounted).

Battle Drill 4
REACT TO AMBUSH (PLATOON OR SQUAD)
(DISMOUNTED)

SITUATION: If the platoon or squad (dismounted element), enters a kill zone, and the enemy initiates an ambush with a casualty-producing device and a high volume of fire, the squad or platoon takes the following actions.

REQUIRED ACTIONS: (Figure 3-8.)

1. In a near ambush (within hand-grenade range), soldiers receiving fire immediately return fire; take up covered or assume prone positions; throw fragmentation, concussion, and smoke grenades.

a. Immediately after the grenades detonate, soldiers in the kill zone assault through the ambush using fire and movement.

b. BFVs and soldiers not in the kill zone immediately—

- Identify enemy positions.
- Initiate immediate suppressive fires against the enemy.
- Shift fires as the soldiers in the kill zone assault through the ambush.

2. In a far ambush (beyond hand-grenade range), soldiers receiving fire immediately return fire, take up covered positions, and suppress the enemy by—

- Destroying or suppressing enemy crew-served weapons.
- Obscuring the enemy position with smoke (M203).
- Sustaining suppressive fires.

a. Soldiers (squads or teams) not receiving fires move by a covered and concealed route to a vulnerable flank of the enemy position and assault using fire and movement techniques.

b. BFVs and soldiers in the kill zone continue suppressive fires and shift fires as the assaulting squad or team fights through the enemy position.

c. The platoon leader directs the vehicles to move to positions where they can place effective fires on the enemy or the platoon leader conducts a flank attack, if he determines that there are no antitank weapons in the ambush.

3. The platoon FO calls for and adjusts indirect fires as directed by the platoon leader. On order, he lifts fires or shifts them to isolate the enemy position or to attack them with indirect fires as they retreat.

4. The platoon or squad leader reports, reorganizes as necessary, and continues the mission.

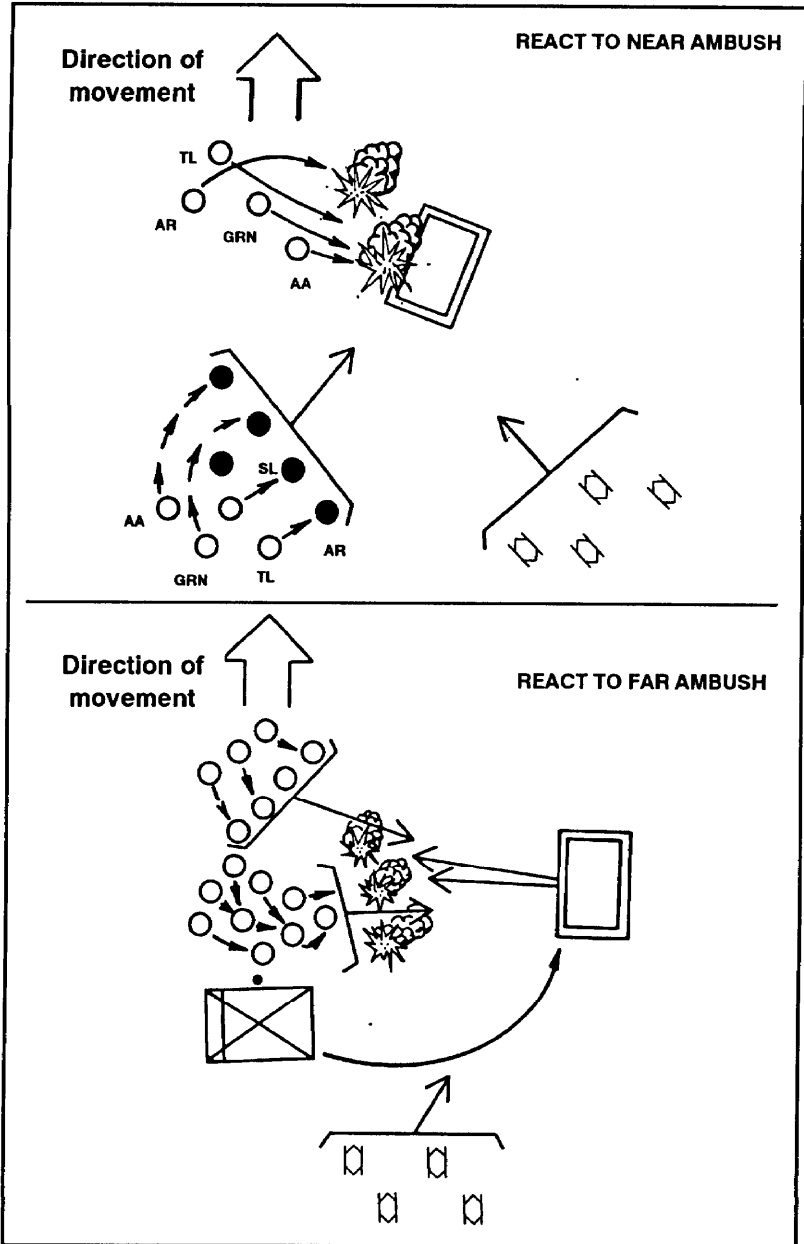

Figure 3-8. React to ambush (dismounted).

Battle Drill 4A
REACT TO AMBUSH (PLATOON)
(MOUNTED)

SITUATION: If the platoon is mounted, enters a kill zone, and the enemy initiates an ambush with a light antiarmor weapon and a high volume of fire, the platoon takes the following actions.

REQUIRED ACTIONS: (Figure 3-9.)

1. Vehicles in the section in the kill zone immediately return fire, while moving out of the kill zone or moving to covered positions within the kill zone and continue to fire on the ambush position with the highest possible volume of fire.

2. Soldiers in disabled vehicles in the kill zone dismount immediately, assume covered and concealed positions, and add their suppressive fires against the enemy.

3. The section in the kill zone gains suppressive fire.

a. Destroys or suppresses enemy weapons firing most effectively against the section.

b. Obscures the enemy position with smoke.

c. Sustains suppressive fires.

d. The section not in the kill zone moves by a covered and concealed route to a vulnerable flank of the enemy position and assaults across the enemy position mounted. (Battle Drill 1 or 1A.)

e. BFVs and soldiers in the kill zone continue suppressive fires and shift fires as the assaulting section fights through the enemy position.

4. The platoon leader calls for and adjusts indirect fires as directed by the platoon leader. On order, he lifts fires or shifts them to isolate the enemy position, or to attack them with indirect fires as they retreat.

5. The platoon leader reports, reorganizes as necessary, and continues the mission. (If the platoon cannot continue the assault, it breaks contact. See Battle Drill 3A, Break Contact [Mounted].)

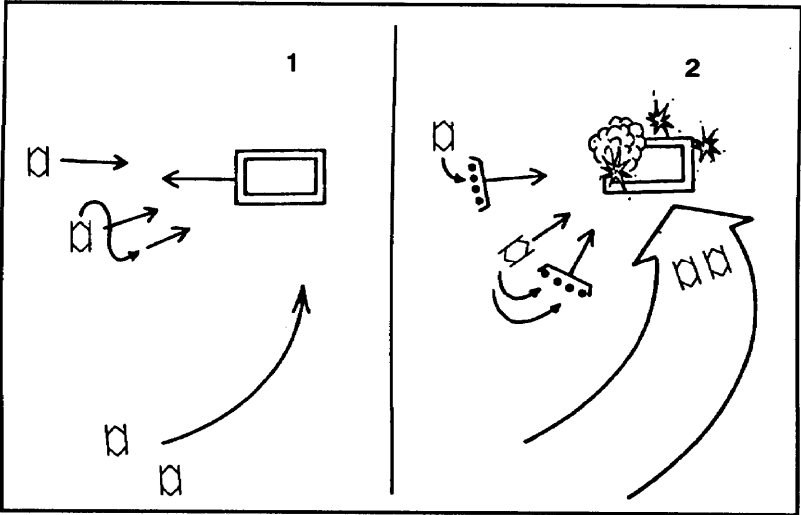

Figure 3-9. React to ambush (mounted).

Battle Drill 5
ENTER BUILDING/CLEAR ROOM/BUILDING
(PLATOON)

SITUATION: Operating as part of a larger force, the platoon is moving (mounted or dismounted) and is operating within supporting range of the BFVs when it receives fire from the enemy in a building.

NOTE: The discussion that follows assumes that the infantry squad is supported only by the platoon's organic weapons. The preferred method of entering a building is to use a tank main gun round, direct-fire artillery round, or TOW, Dragon, or Hellfire missile to clear the first room. Additionally, some MOUT situations may require precise application of firepower. This is true of a MOUT environment where the enemy is mixed with noncombatants. The presence of civilians can restrict the use of fires and reduce the combat power available to a platoon leader. His platoon may have to operate in "no fire" areas. Rules of engagement (ROE) can prohibit the use of certain weapons until a specific hostile action takes place. The use of hand grenades and suppressive fire to enter rooms may be prohibited to preclude noncombatant casualties and collateral damage. All leaders must be aware of the ROE. They must include the precise use of weapons in their planning for MOUT missions. This includes how the platoon will employ its organic weapons including snipers and other weapon systems it may have in support; for example, AC 130 or AH 64 aircraft. They must coordinate the use of marking systems to prevent casualties due to friendly fire. FM 90-10 and FM 90-10-1 provide additional techniques for platoons and squads in MOUT.

REQUIRED ACTIONS: (Figures 3-10 and 3-11, pages 3-36 and 3-37.)

1. The section or squad in contact reacts to contact.
2. The platoon gains suppressive fires.
 - a. The section or squad in contact establishes a base-of-fire position. If mounted, the squad dismounts, establishes local security, and adds its suppressive fires against the enemy. If dismounted, the platoon leader, his RATELO, platoon FO, and the other squad leader move forward to link up with the squad leader of the squad in contact.
 - b. The platoon sergeant repositions the BFVs if necessary, to provide additional observation and supporting fires against the enemy.
3. The platoon leader determines that he can maneuver by identifying—
 - a. The building and any obstacles.
 - b. The size of the enemy force engaging the platoon.

- c. An entry point. (Assaulting squad should enter the building at the highest level possible.)
- d. A covered and concealed route to the entry point.
4. The base-of-fire element (the BFVs and the squad in contact)—
 - a. Destroys or suppresses enemy weapons that are firing the most effectively against the squad.
 - b. Obscures the enemy position with smoke (M203).
 - c. Sustains suppressive fires.
5. The platoon leader designates the entry point of the building and directs one squad to enter the building and secure a foothold.
6. The squad leader directs the fire team in contact to support the entry of the other fire team into the building.
7. If necessary, the base-of-fire team repositions to isolate the building as well as continue suppressive fires. (Normally, the platoon has added its supporting fires against the enemy.)
8. The squad leader designates the entry point of the building. The platoon and squad shift direct fires and continue to suppress the enemy in adjacent positions and to isolate the building. The platoon FO lifts indirect fires or shifts them beyond the building.
9. The squad leader and the assaulting fire team approach the building and position themselves at either side of the entrance. (Soldiers should avoid entering buildings through doors and windows, because they will normally be covered by enemy weapons inside the building.)

DANGER
COOK-OFF TRAINING WITH LIVE FRAGMENTATION
HAND GRENADES IS PROHIBITED.

10. Allowing cook-off time (two seconds maximum), and shouting FRAG OUT, the lead soldier of the assaulting fire team prepares and throws a grenade into the building.

DANGER
IF WALLS AND FLOORS ARE THIN, THEY DO NOT
PROVIDE PROTECTION FROM HAND GRENADE
FRAGMENTS.

11. After the explosion, the next soldier enters the building and positions himself to the right (left) of the entrance, up against the wall, engages all identified or likely enemy positions with rapid, short bursts of

automatic fire, and scans the room. The rest of the team provides immediate security outside the building.

a. The size and shape of the room may cause the soldier entering the room to move to the left or right. The first soldier in the room decides where the next man should position himself and gives the command NEXT MAN IN, LEFT (or RIGHT). The next man shouts COMING IN, LEFT (RIGHT), enters the building, positions himself to the left of the entrance, up against the wall, and scans the room. Once in position, he shouts NEXT MAN IN (RIGHT or LEFT).

b. Depending on the enemy's situation, the size of the entry and the training of the squad, two soldiers can enter the room simultaneously after the grenade detonates. The soldier from the right side of the entry enters, fires from left to right, and moves to right with his back to the wall. At the same time, the soldier on the left enters from the left, fires from right to left, and moves to the left with his back to the wall. One soldier goes high, the other low, to prevent firing at one another. This method puts more firepower in the room more quickly, but is more difficult and requires more practice. When both soldiers are in position, the senior soldier gives the command NEXT MAN IN (RIGHT or LEFT).

12. The assaulting fire team leader shouts COMING IN (RIGHT or LEFT), enters the building initially moving left or right and against the wall, and positions himself where he can control the actions of his team. He does not block the entrance way. He makes a quick assessment of the size and shape of the room, and begins to clear the room. He determines if the remaining man in his team is required to assist in clearing the room.

a. If the team leader decides to bring the last man in, he shouts NEXT MAN IN LEFT (or RIGHT). The last man in the fire team shouts COMING IN LEFT (or RIGHT), enters the building and begins to clear through the room.

b. If the team leader decides not to bring the last man in, he shouts NEXT MAN, STAND FAST. The last man remains outside the building and provides security from there. The team leader then directs the soldier on the right of the entrance to begin clearing. The team leader reports to the squad leader and then assumes the duties of the soldier on the right of the entrance to provide support.

DANGER

WHILE CLEARING ROOMS, SOLDIERS MUST BE ALERT FOR TRIP WIRES AND BOOBY TRAPS. THEY SHOULD NOT EXPOSE THEMSELVES THROUGH OPEN WINDOWS OR DOORS.

13. Once the room is cleared, the team leader signals to the squad leader that the room is cleared.

14. The squad leader enters the building and marks the entry point in accordance with the platoon SOP. The squad leader determines whether or not his squad can continue to clear rooms and still maintain suppressive fires outside the building. Normally, it takes a platoon to clear a building.

15. The squad leader and assault fire team move to the entrance of the next room to be cleared and position themselves on either side of the entrance. The squad enters and clears all subsequent rooms by repeating the actions discussed in paragraphs 8 through 12, above.

16. The squad leader directs the team to continue and clear the next room. The squad leader rotates fire teams as necessary to keep the soldiers alert, to equitably distribute the dangerous duties, and to continue the momentum of the attack.

17. The squad leader follows the fire team that is clearing to ensure that cleared rooms are properly marked in accordance with the platoon SOP.

18. The squad leader assesses the situation to determine if he can continue clearing the building. He reports the situation to the platoon leader. The platoon follows the success of the entry into the building.

19. The squad consolidates its position in the building and then reorganizes as necessary. Leaders redistribute ammunition.

NOTE: Normally the platoons will suppress enemy in buildings with the BFVs

20. The platoon leader moves into the building with the trail fire team of the squad that entered the building and directs the squad to continue to clear the building or calls for the other squad to move into the building and begin clearing rooms systematically. The platoon clears the building by repeating the actions discussed in paragraphs 8 through 12 above to clear all subsequent rooms.

21. The platoon leader rotates squads as necessary to keep his men fresh and to maintain the momentum of the action.

22. The base-of-fire element—

a. Repositions, if necessary, to continue to isolate and suppress the building from the outside.

b. Ensures that all friendly forces enter the building only through the designated entry point.

23. The platoon sergeant calls forward ammunition resupply and organizes teams to move it forward into the building.

24. The platoon leader reports to the company commander that his platoon has cleared the building or that he is no longer able to continue clearing.

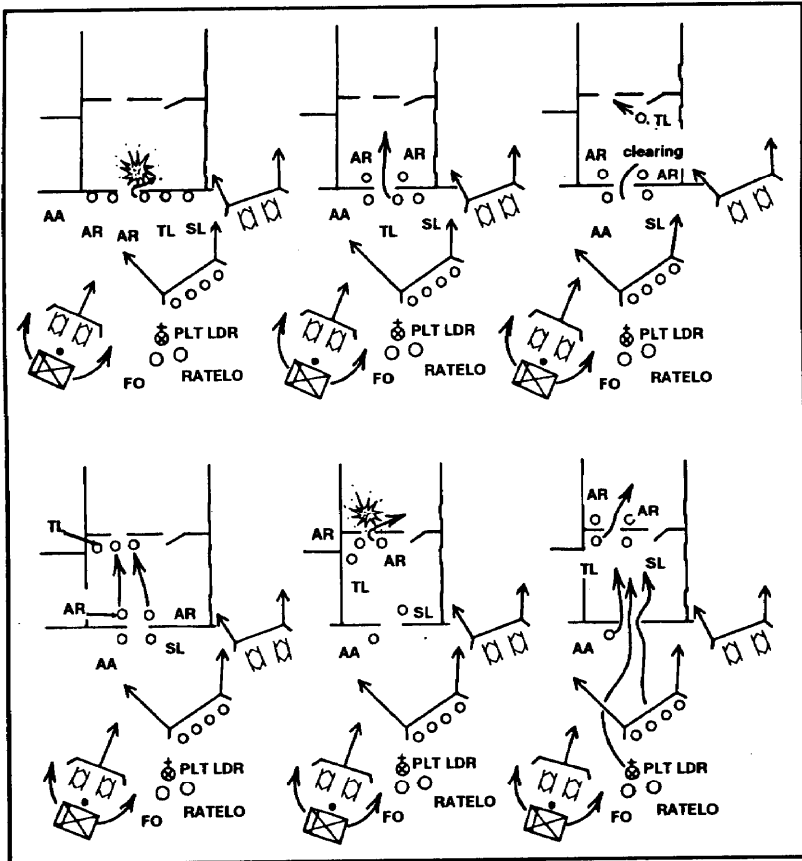

Figure 3-10. Enter and clear a building (platoon).

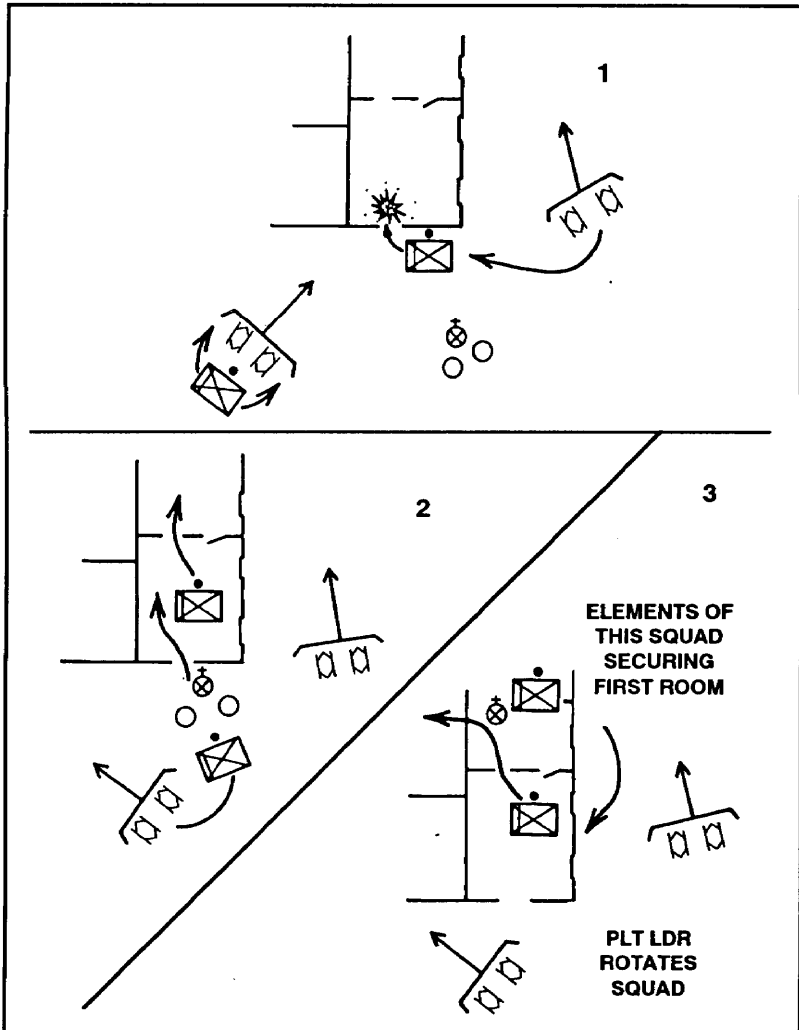

Figure 3-11. Enter a building and clear a room (squad).

Battle Drill 6
ENTER/CLEAR A TRENCH (PLATOON)

SITUATION: The platoon is attacking as part of a larger force and identifies enemy in a trench line. The platoon deploys and establishes a base of fire. The platoon leader determines that he has sufficient combat power to maneuver and assault the trench line.

REQUIRED ACTIONS: (Figures 3-12, 3-13, and 3-14, pages 3-41 through 3-43.)

1. The platoon leader directs one squad to enter the trench and secure a foothold.

2. The platoon leader designates the entry point of the trench line and the direction of movement once the platoon begins clearing.

3. The platoon sergeant positions BFVs to suppress the trench and isolate the entry point.

4. The assaulting squad executes actions to enter the trench and establish a foothold. The squad leader directs one fire team to assault and one fire team to support by fire initially, then follow and support the assaulting fire team. He designates the entry point of the trench line.

a. The squad leader and the assault fire team move to the last covered and concealed position short of the entry point.

(1) The squad leader marks the entry point.

(2) The base-of-fire element (BFVs and one squad) shifts direct fires away from the entry point and continues to suppress adjacent enemy positions or isolate the trench as required.

(3) The assault fire team leader and the automatic rifleman remain in a position short of the trench to add suppressive fires for the initial entry.

(4) The squad leader takes the two remaining soldiers of the assault fire team (antiarmor specialist and automatic rifleman) and continues toward the entry point. They move in rushes or by crawling.

(5) The squad leader positions himself where he can best control his teams.

b. The first two soldiers (antiarmor specialist and automatic rifleman) of the assault fire team move to the edge of the trench; parallel to the trench and on their backs; on the squad leader's command, cook-off grenades (two seconds maximum), shout FRAG OUT, and throw the grenades into the trench.

(1) After ensuring that both grenades detonate, the soldiers roll into the trench, landing on their feet, and back-to-back. They fire their weapons down the trench in opposite directions. Immediately, both

soldiers move in opposite directions down the trench, continuing to fire three-round bursts. Each soldier continues until he reaches the first corner or intersection. Both soldiers halt and take up positions to block any enemy movement toward the entry point.

(2) At the same time, the squad leader rolls into the trench and secures the entry point.

(3) Upon detonation of the grenades, the assault fire team leader and the automatic rifleman immediately move to the entry point and enter the trench. The squad leader directs them to one of the secured corners or intersections to relieve the antiarmor specialist or automatic rifleman who then rejoins his buddy team at the opposite end of the foothold.

c. The squad leader remains at the entry point and marks it.

d. The squad leader reports to the platoon leader that he has entered the trench and secured a foothold. The platoon follows the success of the seizure of the foothold with the remainder of the platoon as part of the platoon actions to clear a trench line.

e. The squad reorganizes as necessary. Leaders redistribute ammunition.

5. The platoon leader directs the squad that is a part of the base-of-fire element to move into the trench and begin clearing it in the direction of movement from the foothold.

6. The base-of-fire element repositions as necessary to continue suppressive fires.

7. The platoon leader moves into the trench with the assaulting squad.

8. The assaulting squad passes the squad that has secured the foothold and executes actions to take the lead and clear the trench.

a. The squad leader designates a lead fire team and a trail fire team.

b. The lead fire team and the squad leader move to the forward-most secure corner or intersection. The squad leader tells the team securing that corner or intersection that his squad is ready to continue clearing the trench. The trail fire team follows maintaining visual contact with the last soldier of the lead team.

NOTE: Throughout this technique, the team leader positions himself at the rear of the fire team to have direct control (physically, if necessary) of his soldiers. Other soldiers in the fire team rotate the lead. Soldiers rotate the lead to change magazines and prepare grenades. Rotating the lead provides constant suppressive fires down the trench and maintains the momentum of the attack as the squad clears the trench.

c. The lead fire team passes the element securing the foothold.

(1) The lead soldier of the fire team moves abreast of the soldier securing the corner or intersection, taps him, and announces TAKING THE LEAD.

(2) The soldier securing the corner or intersection acknowledges that he is handing over the lead by shouting OKAY. He allows the fire team to pass him.

d. The lead fire team starts clearing in the direction of movement. They arrive at a corner or intersection.

(1) Allowing for cook-off (two seconds maximum) and shouting FRAG OUT, the second soldier prepares and throws a grenade around the corner.

(2) Upon detonation of the grenade, the lead soldier moves around the corner firing three-round bursts and advancing as he fires. The entire fire team follows him to the next corner or intersection.

e. The squad leader—

(1) Follows immediately behind the lead team.

(2) Ensures that the trailing fire team moves up and is ready to pass the lead at his direction.

(3) Rotates fire teams as necessary to keep his soldiers alert and to maintain the momentum of the attack.

(4) Requests indirect fires, if necessary, through the platoon leader. (The squad leader also directs the employment of the M203 to provide immediate suppression against positions along the trench line.)

DANGER

THE FIRE TEAMS MUST MAINTAIN SUFFICIENT INTERVAL TO PREVENT THEM FROM BEING ENGAGED BY THE SAME ENEMY FIRES.

f. At each corner or intersection, the lead fire team performs the same actions described above (paragraph d).

g. If the lead soldier finds that he is nearly out of ammunition before reaching a corner or intersection, he announces AMMO.

(1) Immediately, the lead soldier stops and moves against one side of the trench, ready to let the rest of the team pass. He continues to aim his weapon down the trench in the direction of movement.

(2) The next soldier ensures that he has a full magazine, moves up abreast of the lead soldier, taps him and announces TAKING THE LEAD.

(3) The lead soldier acknowledges that he is handing over the lead by shouting OKAY, positions rotate, and the squad continues forward.

h. The trailing fire team secures intersections and marks the route within the trench as the squad moves forward. The trailing fire team leader ensures that follow-on squads relieve his buddy teams to maintain security.

i. The squad leader reports the progress of the clearing operation. (The base-of-fire element must be able to identify the location of the lead fire team in the trench at all times.)

9. The platoon leader rotates squads to keep soldiers alert and to maintain the momentum of the assault.

10. The platoon sergeant calls forward ammunition resupply and organizes teams to move it forward into the trench.

11. The base-of-fire element ensures that all friendly forces move into the trench **ONLY** through the designated entry point. (All movement must be made in the trench to avoid fratricide.)

12. The platoon leader reports to the company commander that the trench line is secured, or that he is no longer able to continue clearing.

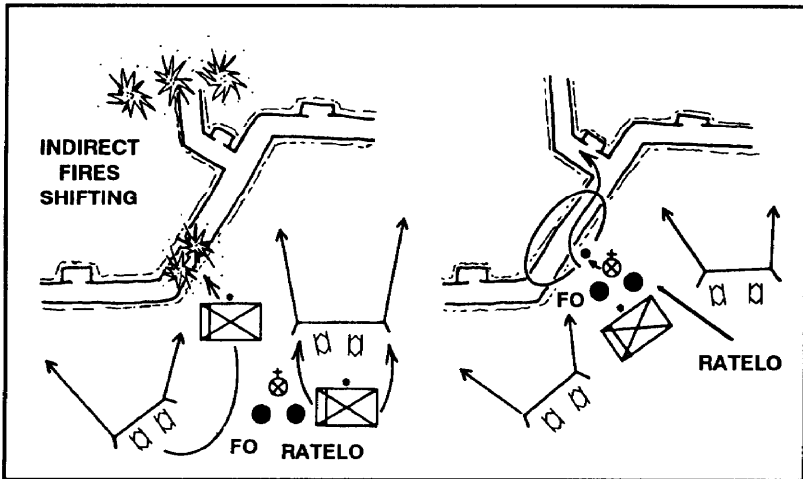

Figure 3-12. Clear a trench line (platoon).

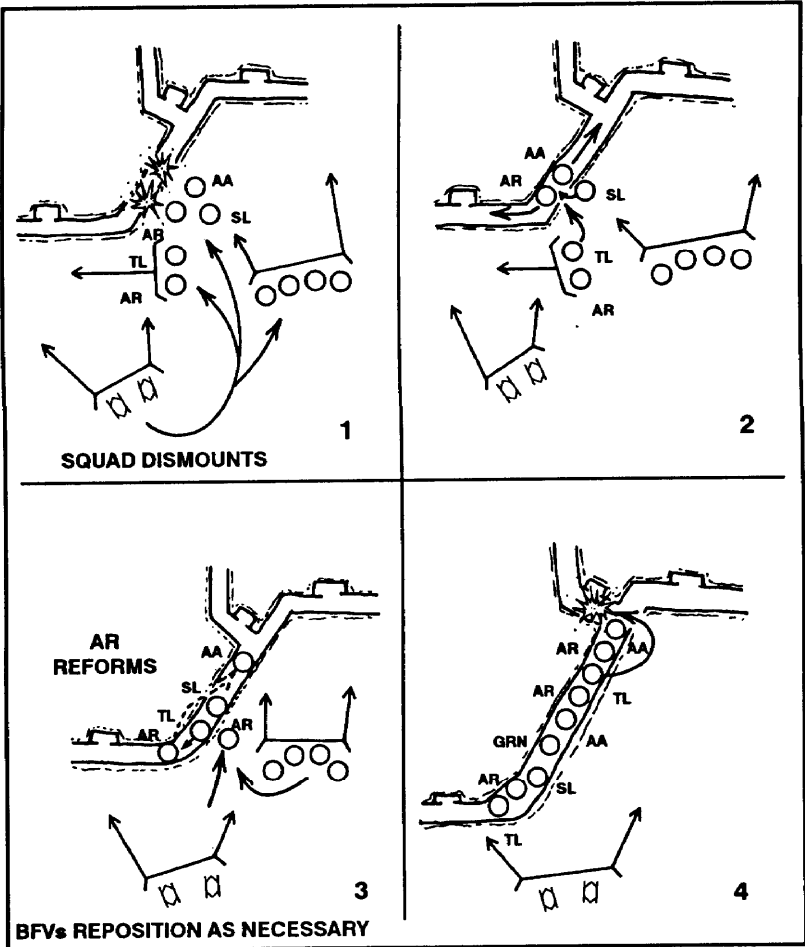

Figure 3-13. Enter a trench line (squad).

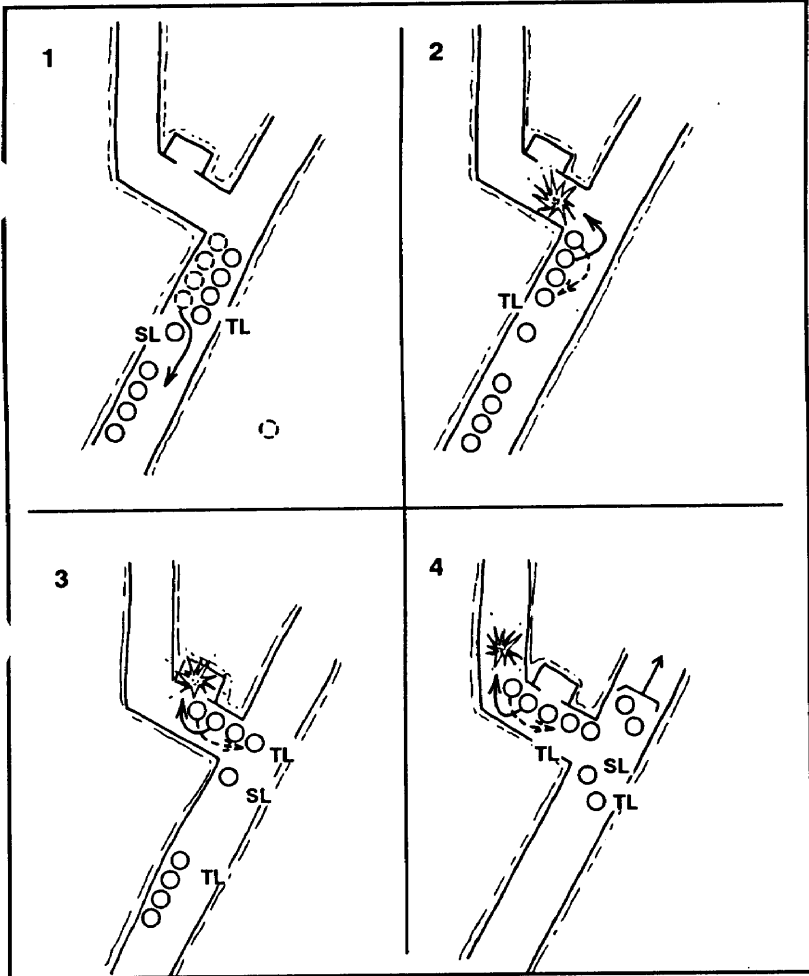

Figure 3-14. Clear a trench line (squad).

Battle Drill 7

KNOCK OUT BUNKERS (PLATOON)

SITUATION: The platoon receives fire from enemy in bunkers while moving (mounted or dismounted) as a part of a larger force and dismounted element is required to clear the bunkers.

REQUIRED ACTIONS: (Figures 3-15 and 3-16, pages 3-46 and 3-47.)

1. The section or squad in contact reacts to contact.
2. The platoon gains suppressive fires.
 - a. The section or squad in contact establishes a base of fire.
 - b. If mounted, the squad dismounts, establishes local security, and adds its suppressive fires against the enemy. The platoon leader, his RATELO, and platoon FO, dismount and if not the lead section, move forward with the other squad leader and link up with the squad leader of the lead squad. If dismounted, the platoon leader, his RATELO, platoon FO, and the squad leader of the other squad move forward to link up with the lead squad leader.
 - c. The platoon sergeant repositions the mounted element, if necessary, to provide additional observation and base of fire.
 - d. The base-of-fire element (the BFVs and the squad in contact)—
 - (1) Destroys or suppresses enemy crew-served weapons first.
 - (2) Obscures the enemy position with smoke (M203).
 - (3) Sustains suppressive fires.
 - e. The platoon FO calls for and adjusts indirect fires as directed by the platoon leader.
3. The platoon leader determines that he can maneuver by identifying—
 - a. The enemy bunkers, other supporting positions, and any obstacles.
 - b. The size of the enemy force engaging the platoon. (The number of enemy automatic weapons, the presence of any vehicles, and the employment of indirect fires are indicators of enemy strength.)
 - c. A vulnerable flank of at least one bunker.
 - d. A covered and concealed flanking route to the flank of the bunker
4. The platoon leader determines which bunker is to be assaulted first and directs the squad not in contact to knock it out.
 - a. The platoon FO shifts indirect fires to isolate enemy positions.
 - b. On the platoon leader's signal, the base-of-fire element lifts fires or shifts fires to the opposite side of the bunker from which the squad is assaulting.

5. The assaulting squad, with the platoon leader and his RATELO, move along the covered and concealed route and take action to knockout the bunker.

a. The squad leader moves with the assaulting fire team along the covered and concealed route to the flank of the bunker.

(1) The assaulting fire team approaches the bunker from its blind side and does not mask the fires of the base-of-fire element.

(2) Soldiers constantly watch for other bunkers or enemy positions in support of it.

b. Upon reaching the last covered and concealed position—

(1) The fire team leader and the automatic rifleman remain in place and add their fires to suppressing the bunker (includes the use of LAW or AT4s).

(2) The squad leader positions himself, where he can best control his teams. On the squad leader's signal, the base-of-fire element lifts fires or shifts fires to the opposite side of the bunker from the assaulting fire team's approach.

(3) The squad leader continues forward with the automatic rifleman and antiarmor specialist to the blind side of the bunker. One soldier takes up a covered position near the exit, while one soldier cooks off (two seconds maximum) a grenade, shouts FRAG OUT, and throws it through an aperture

(4) After the grenade detonates, the soldier covering the exit enters the bunker, firing short bursts, to destroy the enemy. The soldier who throws the grenade should not be the first one to clear the bunker.

c. The squad leader inspects the bunker to ensure that it has been destroyed. He reports, reorganizes as needed, and continues the mission. The platoon follows the success of the attack against the bunker and continues the attack of other bunkers.

6. The platoon leader repositions the base-of-fire element as necessary to continue to isolate and suppress the remaining bunkers and to maintain suppressive fires.

7. The platoon leader either redesignates the squad that is part of the base-of-fire to move up and knock out the next bunker; or, he directs the assaulting squad to continue and knock out the next bunker.

NOTE: The platoon leader must consider the condition of his assaulting squad (ammunition and exhaustion) and rotate squads as necessary.

8. The assaulting squad takes action to knock out the next bunker (see paragraph 5, above).

9. The platoon leader reports, reorganizes as necessary, and continues the mission. The company follows up the success of the platoon attack and continues to assault enemy positions.

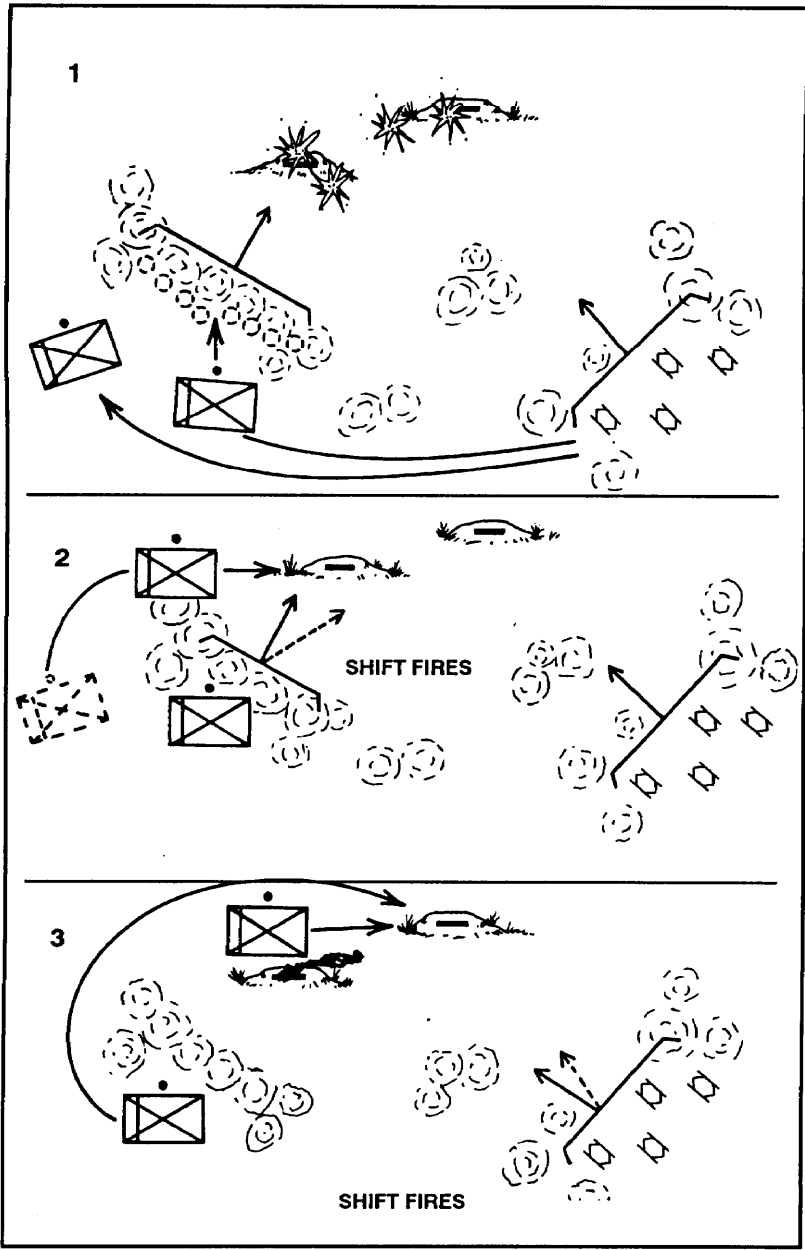

Figure 3-15. Knock out bunkers (platoon).

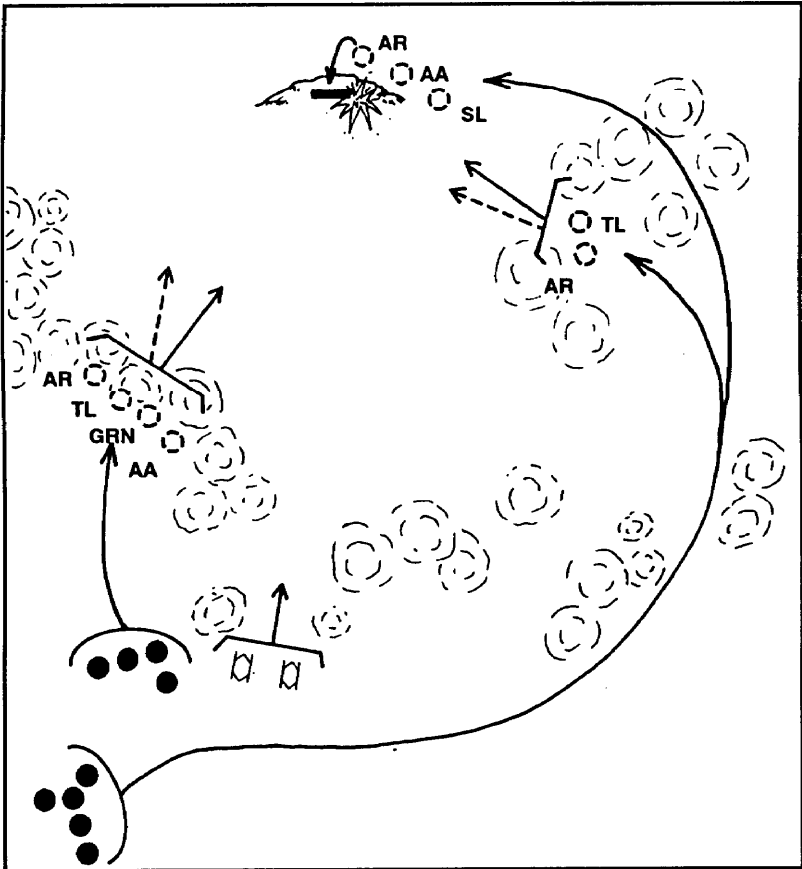

Figure 3-16. Knock out bunkers (squad).

Battle Drill 8
CONDUCT INITIAL BREACH OF A MINED WIRE
OBSTACLE (PLATOON)

SITUATION: The platoon is operating as part of a larger force (mounted or dismounted). The lead section or squad identifies a wire obstacle, reinforced with mines, that cannot be bypassed. The enemy begins to engage the platoon from positions on the far side of the obstacle.

REQUIRED ACTIONS: (Figure 3-17, page 3-51.)

1. The section/squad in contact reacts to contact.
2. The platoon gains suppressive fires. The section/squad in contact establishes a base-of-fire position. The platoon leader, his RATELO, platoon FO, and the squad leader of the other squad move forward to link up with the squad leader of the squad in contact.
3. The platoon sergeant repositions the BFVs, if necessary, to provide additional observation and supporting fires.
4. The platoon leader determines that he can maneuver by identifying—
 - a. The obstacle and enemy positions covering it by fire.
 - b. The size of the enemy force engaging the section or squad. (The number of enemy automatic weapons, the presence of any vehicles, and the employment of indirect fires are indicators of enemy strength.)
 - c. A breach point.
 - d. A covered and concealed route to the breach point.
5. The platoon leader directs the BFVs and the lead squad to support the movement of the other squad to the breach point. He indicates the enemy positions to be suppressed, and the route that the rest of the platoon will take to the breach point. He also gives instructions for lifting and shifting fires.
6. On the platoon leader's signal, the base-of-fire element—
 - a. Destroys or suppresses enemy crew-served weapons.
 - b. Obscures the enemy position with smoke (M203).
 - c. Sustains suppressive fires at the lowest level possible.
7. The platoon leader then directs the squad leader to designate the breach point and lead the breach squad along the covered and concealed route to the breach point.
8. The platoon FO calls for and adjusts indirect fires as directed by the platoon leader.

9. The breach squad executes actions to breach the obstacle (footpath).

a. The squad leader directs one fire team to support the movement of the other fire team to the breach point.

b. The squad leader identifies the breach point.

c. The base-of-fire element continues to provide suppressive fires and isolates the breach point.

d. The breaching fire team, with the squad leader, moves to the breach point using the covered and concealed route.

(1) The squad leader and breaching fire team leader employ smoke grenades to obscure the breach point. The platoon base-of-fire element shifts direct fires away from the breach point and continues to suppress key enemy positions. The platoon FO lifts indirect fires or shifts them beyond the obstacle.

(2) The breaching fire team leader positions himself and the automatic rifleman on one flank of the breach point to provide close-in security.

(3) Under the direction of the squad leader, the antiarmor specialist and automatic rifleman of the breaching fire team probe for mines, and cut the wire obstacle, marking their path as they proceed.

(4) Once the obstacle has been breached, the breaching fire team leader and the automatic rifleman move to the far side of the obstacle and take up covered and concealed positions. They signal to the squad leader when they are in position and ready to support.

e. The squad leader signals the base-of-fire team leader to move his fire team up and through the breach. He then moves through the obstacle and joins the breaching fire team leader and the automatic rifleman, leaving the antiarmor specialist and automatic rifleman on the nearside of the breach to guide the rest of the squad (and platoon) through.

f. Using the same covered and concealed route as the breaching fire team, the base-of-fire team moves through the breach and takes up covered and concealed positions on the far side.

10. The breach squad leader reports the situation to the platoon leader and posts guides at the breach point.

11. The platoon leader redesignates the base-of-fire squad as the assault squad once the breach has been made. (Normally, it follows the covered and concealed route of the breach squad.)

12. The platoon leader then leads the assault squad along the covered and concealed route through the breach in the obstacle and positions it on the far side to support the movement of the remainder of the platoon or assaults the enemy position covering the obstacle.

13. The breaching squad continues to widen the breach to allow vehicles to pass through.

14. The platoon leader reports the situation to the company commander and directs his breaching squad to move up and through the obstacle. The platoon leader leaves guides to guide the company through the breach point.

15. The platoon sergeant brings the mounted element forward and through the breach on the platoon leader's command.

16. The company follows up the success of the platoon as it conducts the breach and continues the assault against the enemy positions.

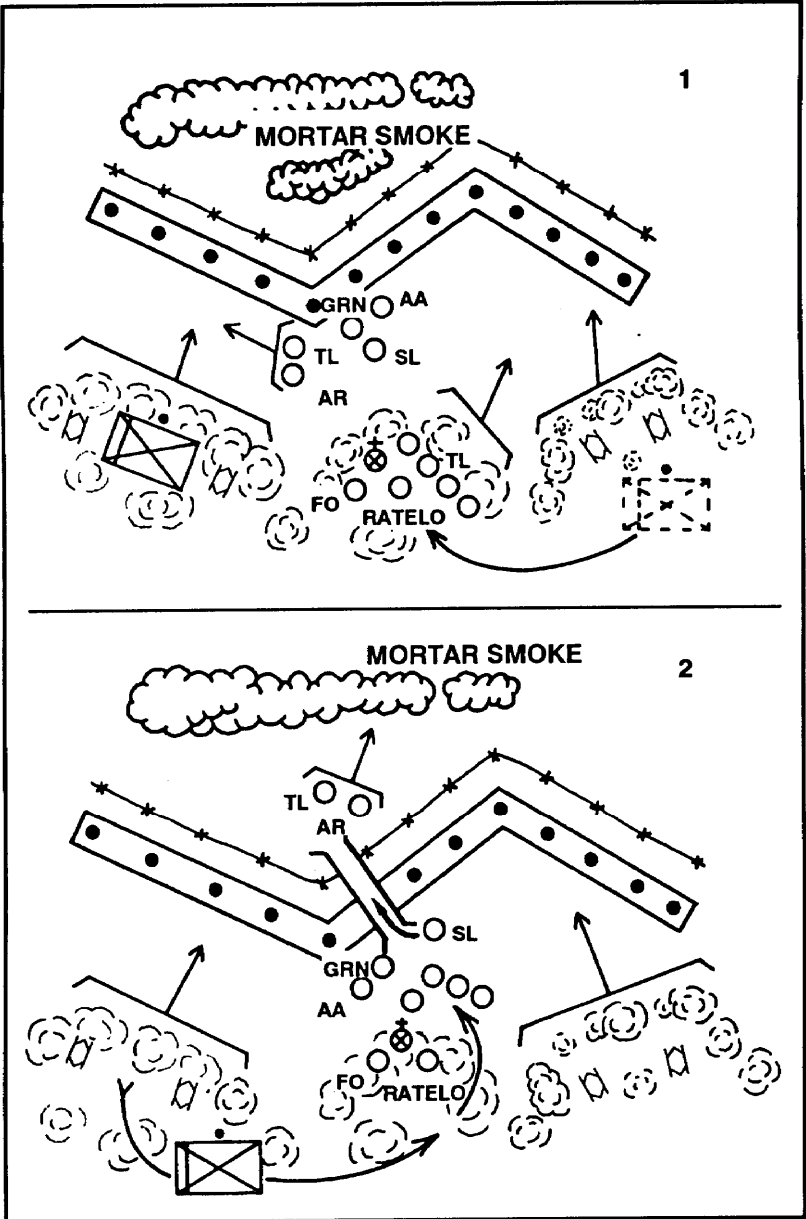

Figure 3-17. Conduct initial breach of a mined wire obstacle (platoon).

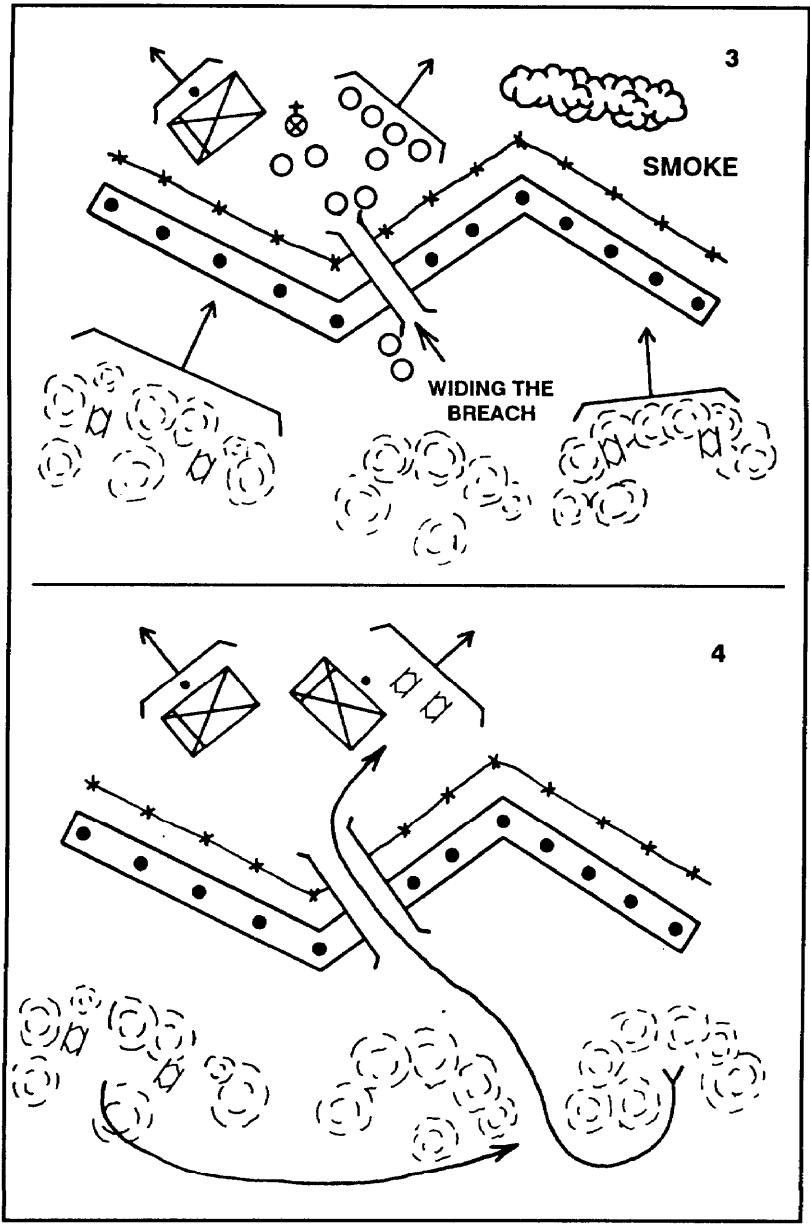

Figure 3-17. Conduct initial breach of a mined wire obstacle (platoon) (continued).

Section II CREW DRILLS

A *crew drill* is a collective action that the crew of a weapon or piece of equipment must perform to successfully use the weapon or equipment in combat or to preserve life. This action is a trained response to a given stimulus such as a simple leader's order or the status of the weapon or equipment. It requires minimal leader orders to accomplish and is standard throughout the Army.

Crew Drill 1
BAIL OUT (CREW/FIRE TEAM)

SITUATION: The BFV, with a fire team mounted, has received hostile fire requiring the crew and fire team to evacuate the vehicle.

REQUIRED ACTIONS:

1. Bailout procedures for the BFV crew.

a. **Bradley commander:**

(1) Alerts soldiers by the intercommunications system or by voice command if the intercommunications system does not work. Commands BAIL OUT.

NOTE: As soldiers bail out they should use the BFV for covert from enemy fires.

(2) Turns the turret power switch to OFF.

(3) Evacuates the vehicle through the BC's hatch.

b. **Gunner:** Evacuates the vehicle through the hatch.

c. **Driver:**

(1) Stops the vehicle.

(2) Shuts down the vehicle by pulling out the fuel control handle.

(3) Lowers the ramp.

(4) Disconnects the CVC helmet and unfastens the seat belt.

(5) Secures his weapon.

(6) Turns the master-power switch to OFF.

(7) Evacuates the vehicle through the driver's hatch, if possible.

If the driver cannot evacuate through the driver's hatch, he exits through the ramp door.

2. Bailout procedures for the troop compartment and fire team members.

a. **Squad leader or fire team leader:**

(1) Announces BAIL OUT.

(2) Pulls the quick disconnect to release the CVC helmet or headsets.

(3) Disconnects the seat belt.

(4) Secures his weapon.

(5) Evacuates the vehicle through the ramp or ramp door.

b. **Fire team members:**

(1) Disconnect the seat belts.

(2) Secure their weapons.

(3) Evacuate the vehicle through the ramp door or the cargo hatch. The fire team member in the No. 4 seat attempts to evacuate through the driver's hatch.

3. Senior man accounts for soldiers and equipment.

Crew Drill 2

EVACUATE INJURED PERSONNEL FROM A BFV

SITUATION: A crewmember or fire team member has been injured.

REQUIRED ACTIONS:

Evacuate BC or Gunner

Evacuation of gunner through the hatch. (If BC is the casualty, the gunner will perform the same actions.)

1. Bradley Commander: Commands EVACUATE THE GUNNER.

2. Driver: Moves to the nearest covered position and halts the vehicle.

3. Bradley Commander:

a. Attempts to rotate the turret to the 6400-mil position.

b. Engages the turret travel lock.

c. Sets the turret drive system switch to OFF.

4. No. 6 and No. 7 Fire Team Members: Exit the vehicle through the ramp access door, the ramp, or if necessary the cargo hatch, and move to the outside of the turret to assist in removing the injured gunner or BC.

5. Bradley Commander: Places the gunner in position for removal from the vehicle. Adjusts the seat to the raised position, being careful not to cause further injury. Unfastens the seat belt.

6. Fire Team Members:

a. Place a pistol belt around the gunner's chest and slowly pull the gunner out. Move the gunner to the front edge of the vehicle. If the gunner and BC are wearing lightweight jumpsuits, grasp the straps on the back of the suit and pull the gunner or BC out of the vehicle.

b. Lower the gunner or BC from the vehicle to the two fire team members on the ground.

c. Place the gunner or BC on the ground and administer first aid. If the gunner cannot be evacuated through the hatches, evacuate through the turret shield door.

7. Bradley Commander: Commands EVACUATE THE GUNNER.

8. Driver: Moves to the nearest covered position and halts the vehicle.

9. Bradley Commander:

a. Rotates the turret to the 6400-mil position.

b. Engages the turret travel lock.

c. Sets the turret drive system switch to OFF.

d. Places the gunner in position for removal from the vehicle, without causing further injury.

10. No. 4 Fire Team Member:

a. Opens the turret shield door, grasps the gunner under the armpits, and pulls him out of the turret.

b. Carries the gunner to a flat surface and administers first aid.

Evacuate Driver

11. Bradley Commander: Commands EVACUATE THE DRIVER.

NOTE: If the driver is unable to halt the vehicle, a fire team member must move forward, behind the driver's seat, and pull the fuel shutoff handle to stop the engine.

12. Gunner:

a. Ensures the turret exposes the driver's hatch.

b. Engages the turret travel lock.

c. Sets the turret drive system switch to the OFF position.

13. Bradley Commander

a. Exits the vehicle.

b. Releases the trim vane.

NOTE: The M2A2 BFV does not have a trim vane attached to the vehicle's front slope. The BC must determine the urgency to evacuate the driver and treat the driver's wounds before deciding to install the work platform.

14. Fire Team Members:

a. Move forward behind the driver and lowers the backrest of the driver's seat, using the backrest release handle on the right side just beneath the backrest, lowers the driver's seat backrest.

b. Assist the BC in removing the driver from the vehicle.

15. Bradley Commander:

a. Opens the driver's hatch.

NOTES:

1. If the driver's hatch is damaged and will not open, the fire team member pulls the driver back into the troop compartment.

2. The BC's duties can be performed by the gunner.

b. Disconnects the CVC helmet and the safety belt.

c. Crosses the driver's arms over his chest. (If this is not possible, wraps a belt around the driver's chest to raise him.)

d. Pulls the driver out of the vehicle and hands him to the fire team member on the ground.

16. Fire Team Members:

- a. Assist the BC in pulling the driver from the vehicle.
- b. Two fire team members dismount to the left front of the vehicle to assist by taking the driver from the BC. They lay him on the ground and administer first aid.
- c. One fire team member remains in the vehicle and assists in the removal of the driver by untying his legs as necessary.

Evacuate Fire Team Member

17. **Fire Team Leader:** Informs the BC that a fire team member is injured.

18. **Bradley Commander:** Commands EVACUATE FIRE TEAM MEMBER.

19. **Driver:** Moves to the nearest covered position, halts the vehicle, and lowers the ramp.

NOTE: Depending on which fire team member is injured, the fire team leader designates which member will assist in evacuating the casualty. If the fire team leader is injured, then the next senior man in the fire team takes charge.

20. **Fire Team Members:** Two fire team members remove the injured member, lay him on the ground, and perform first aid, as needed.

Crew Drill 3 EXTINGUISH A FIRE (CREW)

SITUATION: Upon automatic or manual discharge of the fire suppression system. The BJV crew and fire team are mounted. The BC alerts personnel of a fire.

REQUIRED ACTIONS:

1. Extinguish a fire in the engine compartment.

a. **Bradley Commander:**

(1) Alerts the soldiers of an engine compartment fire by the intercommunications system or by voice command if the intercommunications system does not work. Commands FIRE, ENGINE COMPARTMENT. Rotates the turret to 6400 roils.

DANGER

FAILURE TO PLACE THE TURRET AT 6400 MILS MAY PREVENT THE CARGO HATCH FROM FULLY OPENING. IF THE RAMP OR RAMP ACCESS DOOR FAILS, THE SOLDIER COULD BE TRAPPED INSIDE THE TROOP COMPARTMENT.

(2) Turns the turret power switch to OFF.

b. **Driver:**

- (1) Stops the vehicle.
 - (2) Shuts down the engine by pulling out the fuel control handle.
 - (3) Discharges the Halon bottle by rotating the release valve inside the driver's compartment if it has not been automatically discharged.
 - (4) Lowers the ramp (TM 9-2350-252-10-1 or TM 9-2350-284-10-1).
 - (5) Turns the master power switch to OFF.
 - (6) Disconnects the CVC helmet and unfastens the seat belt.
 - (7) Secures his weapon.
 - (8) Evacuates the vehicle through the driver's hatch, if possible.
- If the driver is unable to evacuate through the driver's hatch, he exits through the ramp.

c. **Fire Team Members:**

- (1) Disconnect the seat belts.
- (2) Squad leader or fire team leader pulls the quick disconnect to release the CVC helmets or headsets.
- (3) Secure their weapons.

(4) The fire team members in the No. 5 and 9 seats secure the rear portable fire extinguishers.

(5) Evacuates the vehicle through the ramp.

d. **Bradley Commander:** Evacuates the vehicle through the BC's hatch.

e. **Gunner:** Evacuates the vehicle through the gunner's hatch.

NOTE: If the fire is not extinguished, the portable fire extinguishers must be used.

2. Extinguish a fire in the troop compartment.

a. **Squad Leader or Fire Team Leader:** Alerts the BC of a troop compartment fire by intercommunications system or by voice command if the intercommunications system does not work. Announces FIRE, TROOP COMPARTMENT.

b. **Bradley Commander:** Turns the turret power to OFF, and evacuates the vehicle through the BC's hatch.

c. **Gunner:** Evacuates the vehicle through the gunner's hatch.

d. **Driver:**

(1) Stops the engine.

(2) Shuts down the vehicle and pulls out the fuel control handle.

(3) Lowers the ramp.

(4) Turns the master power switch to OFF.

(5) Pulls the quick disconnect to release the CVC helmet and seat belt.

(6) Unfastens his seat belt.

(7) Secures his weapon.

(8) Evacuates the vehicle through the driver's hatch.

e. **Fire Team Members:**

(1) Unfasten the seat belts.

(2) The squad or fire team leader pulls the quick disconnect to release the CVC helmets and headsets.

(3) Secures their weapons.

(4) The fire team members in the No. 5 and 9 seats secure the portable fire extinguishers.

(5) Evacuate the vehicle through the ramp.

(6) The fire team member in the No. 9 seat pulls the handle to activate the troop-area fire extinguishers from the outside.

NOTE: If the fire is not extinguished, the portable fire extinguishers are used.

Crew Drill 4

DISMOUNT THE VEHICLE (PLATOON/SQUAD)

SITUATION: The platoon/squad is mounted and must dismount. The platoon leader orders the platoon/section to prepare to dismount.

REQUIRED ACTIONS: (Figure 3-18.)

1. The platoon leader selects the dismount point.
2. The platoon leader orders personnel to dismount.
 - a. Gives the warning PREPARE TO DISMOUNT.
 - b. Designates dismounted platoon's weapons composition; for example, "No Dragons" or "Heavy on AT4s."
 - c. Gives dismount instructions for each vehicle; for example, "Right" (left), distance "Fifty meters," and any identifying terrain feature "Backside of hill."
3. Squad/team leader(s) monitors commands and dismount. He then alerts the soldiers in the troop compartment.
4. The drivers move the vehicles to the designated dismount point and orient the front of the vehicle toward the enemy.
5. The gunners orient the turret to provide overwatching support and supporting fire, if necessary.
6. The platoon leader gives the command DISMOUNT.
7. Fire team members take the M231 FPWs out of the ramp and secure them in the vehicle.
8. The drivers stop the vehicle and lower the ramp or the BC orders the ramp access door opened.
9. The fire team members dismount in the specified order and then move to covered and concealed positions (about 5 meters apart). The fire team then links up with the squads and continues with the rest of the mission. The squad leader establishes contact with the platoon leader.
10. The mounted element occupies covered positions and overmatches the dismounted element with the appropriate weapon.
11. Platoon/squad leader reports to higher headquarters.
12. All squad members search for enemy positions and respond to orders.
13. Squad and fire team leaders position or reposition squad members (if needed).
14. Section leaders reposition the vehicles, as required.

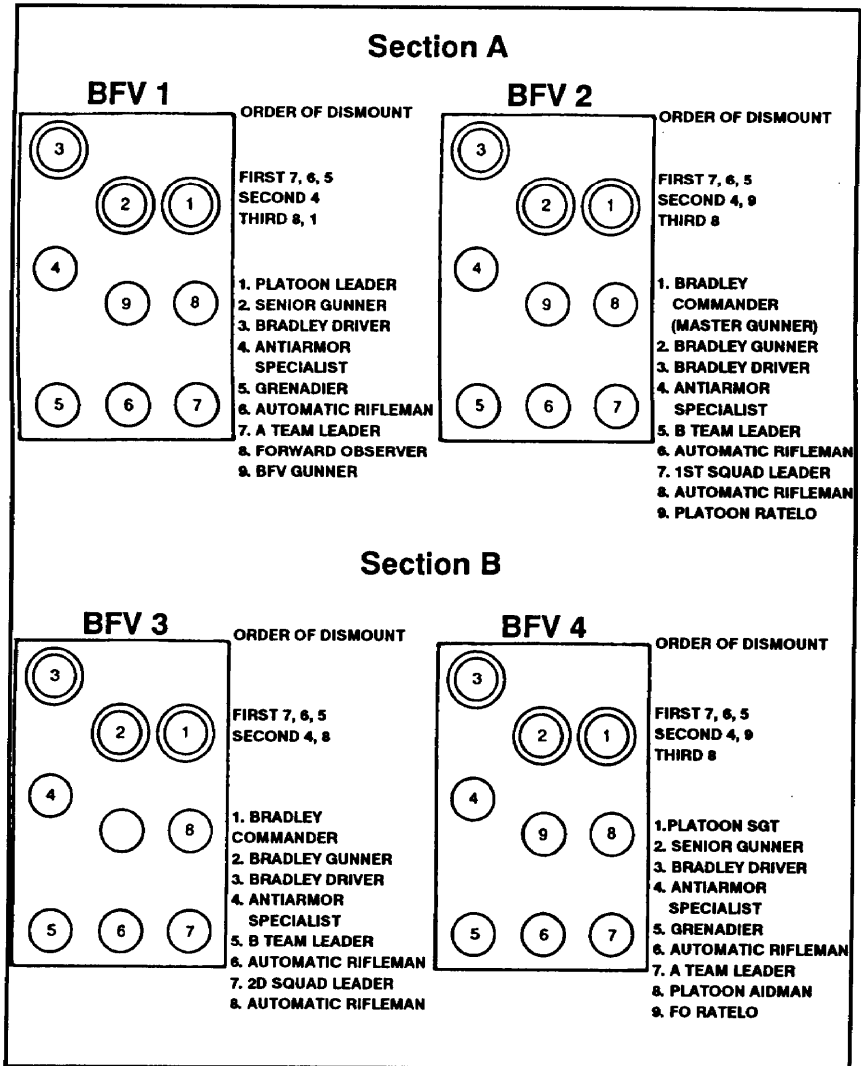

Figure 3-18. BFV order of dismount.

Crew Drill 5

MOUNT THE VEHICLE (PLATOON/SECTION)

SITUATION: The squads are dismounted and must remount the vehicle. The platoon/squad leader orders the platoon to mount their vehicles.

REQUIRED ACTIONS: (Figure 3-19.)

1. The platoon/squad leader(s) gives the order or signal to the squads to mount their BFVs, and designates a mount point.

- Warning PREPARE TO MOUNT.

2. Both elements (mounted and dismounted) move to the mount point using covered and concealed routes.

3. The vehicle crew, using the appropriate weapons, overwatches primary enemy avenues of approach and provides supporting fire and smoke, if necessary.

- The BC orders the driver to lower the ramp, or the fire team to enter through the ramp access door.

4. The platoon/squad leader orders MOUNT. (The order to mount may come with clarifying instructions; for example, "1st Squad, provide a base of fire until 2d Squad is mounted.")

5. Each squad/team mounts in the order specified. The squad leader designates which fire team mounts first; for example, Team Amount first, Team B provide overmatching fires.

6. Soldiers remount the vehicle in reverse sequence of dismount.

7. The platoon leader/BC prepares for mounted operations.

a. Each team leader accounts for all personnel and equipment in the BFV, and reports to the BC. Announces, ALL UP.

b. The platoon leader designates a direction of movement, formation, and movement technique from the mount point.

c. The platoon leader establishes visual or radio contact with the other BCs.

d. The team leader ensures the dismounted weapons are on SAFE once the soldiers have mounted.

e. The BC orders the driver to raise the ramp or the fire team to close the ramp access door. The fire team members in the No. 5 and 6 seats install their FPWs.

8. The platoon leader reports to the company commander.

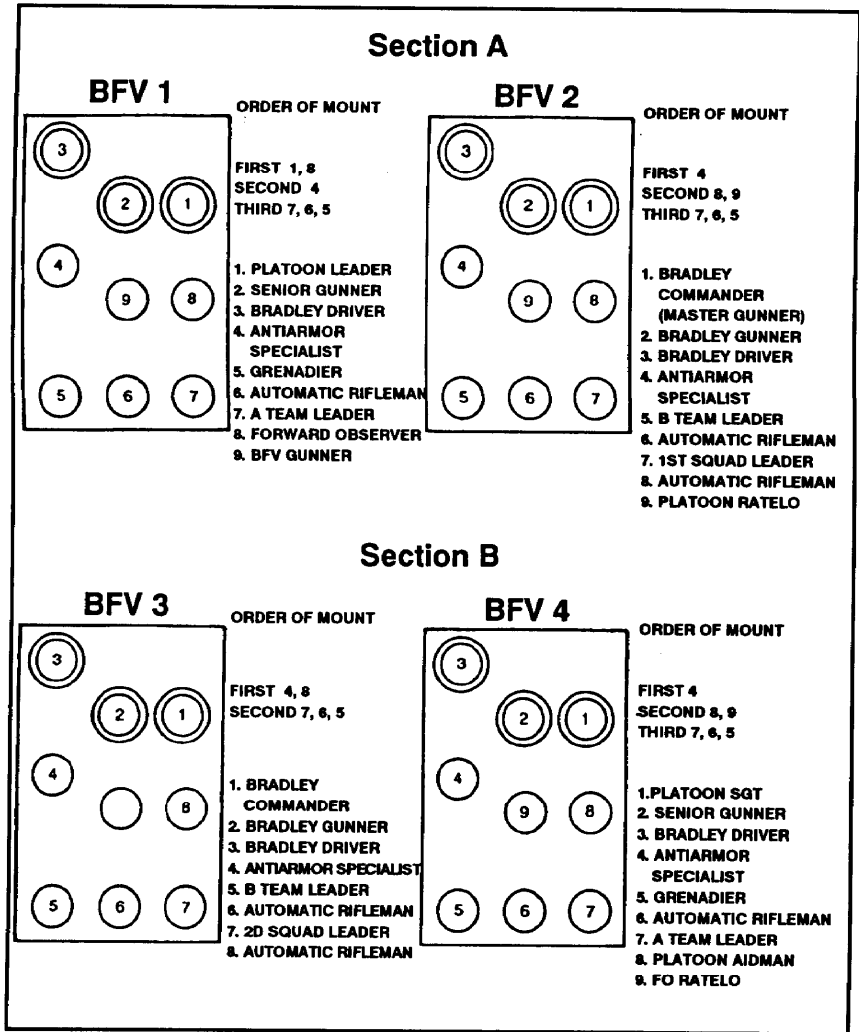

Figure 3-19. BFV order of mount.

CREW DRILL 6
CHANGE FORMATION (MOUNTED) (PLATOON)

SITUATION: The platoon is moving and must change formation. The platoon leader gives arm-and-hand signal, flag signal, or radio for change of formation.

REQUIRED ACTIONS: (Figures 3-20 through 3-35, pages 3-64 through 3-79.)

1. The platoon leader directs the formation change by giving the standard arm-and-hand signals, flag signals, or by radio.
2. The BCs relay arm-and-hand or flag signals.
3. The BCs direct drivers into position in the new formation. The driver maintains the position in the formation based on the platoon leader and wingmen.
4. The BCs traverse the main weapons toward likely enemy positions or assigned sectors and instruct the gunners to scan for targets in their sectors. The BCs give the gunners the limits of their sectors using the turret position indicator (for example, scan from 12 to 2).

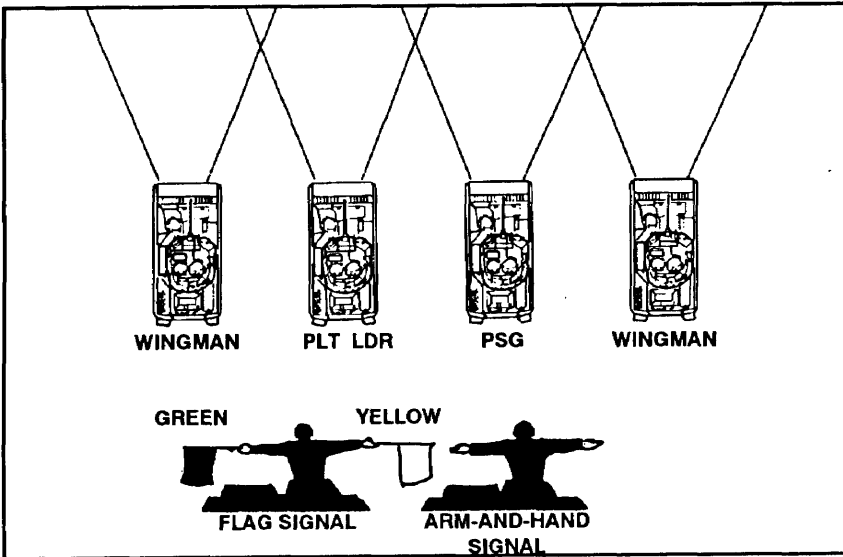

Figure 3-20. Line formation.

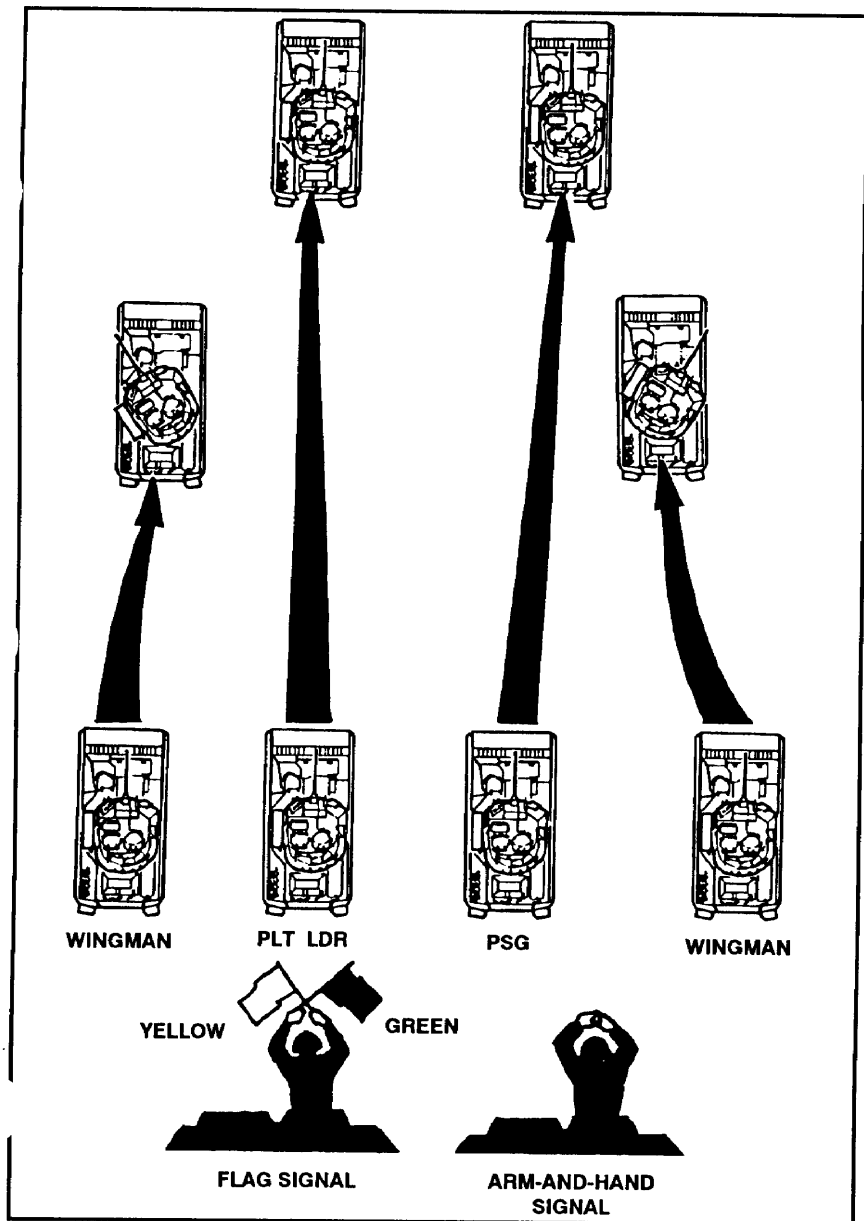

Figure 3-21. Line to wedge formation.

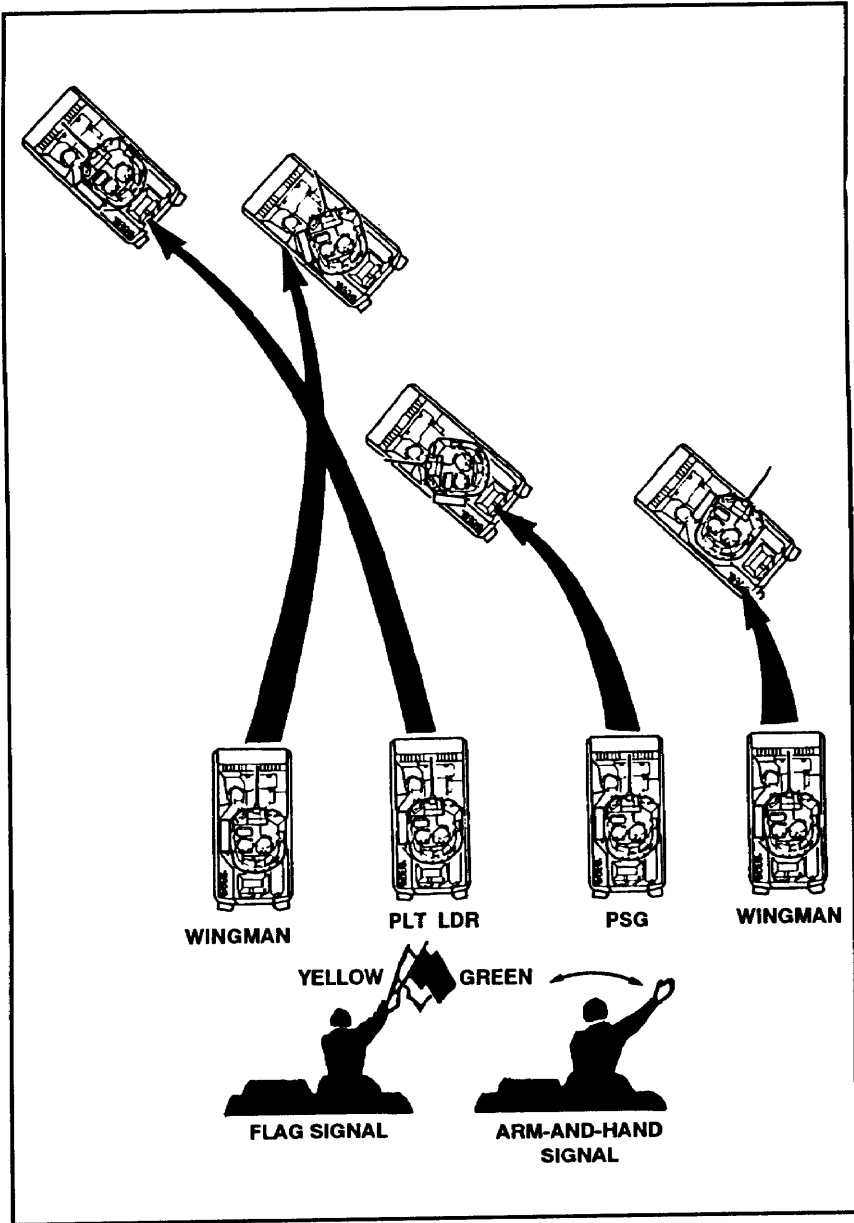

Figure 3-22. Line to column formation.

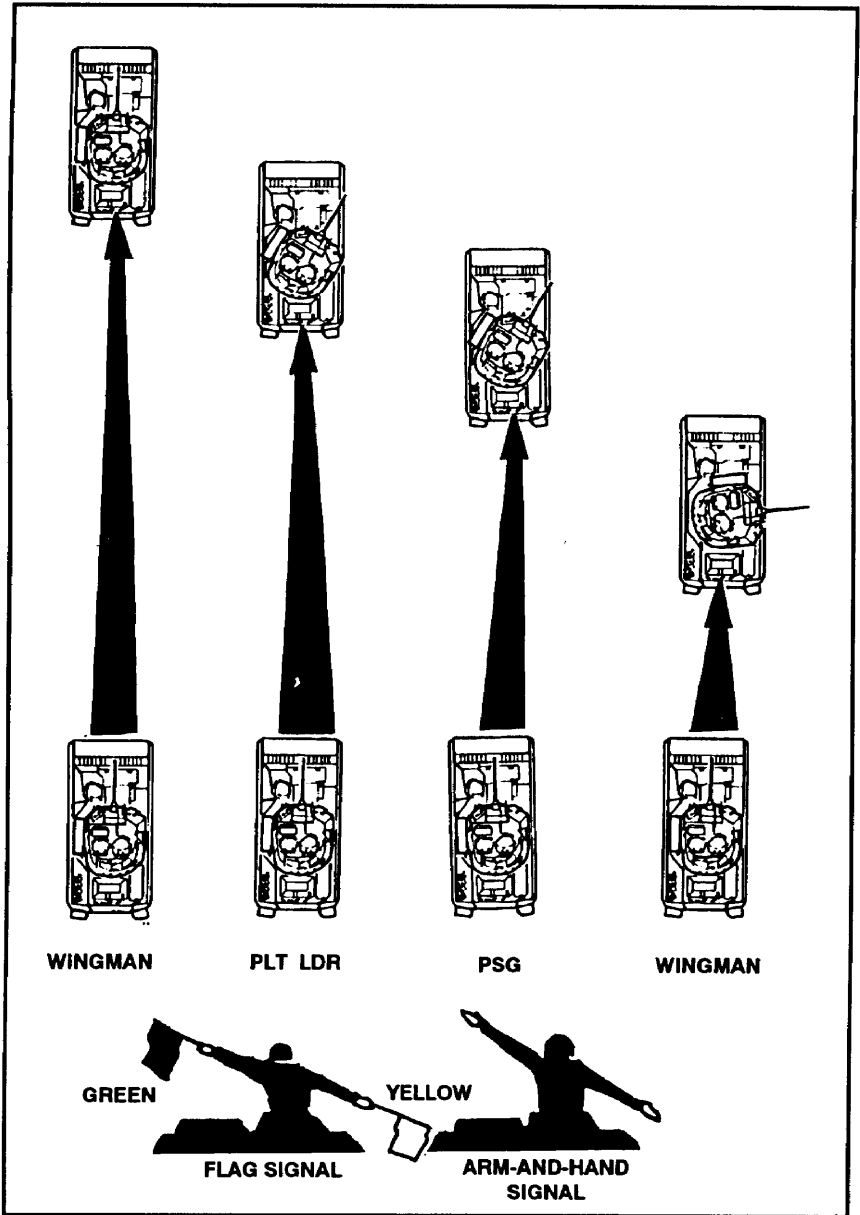

Figure 3-23. Line to echelon formation.

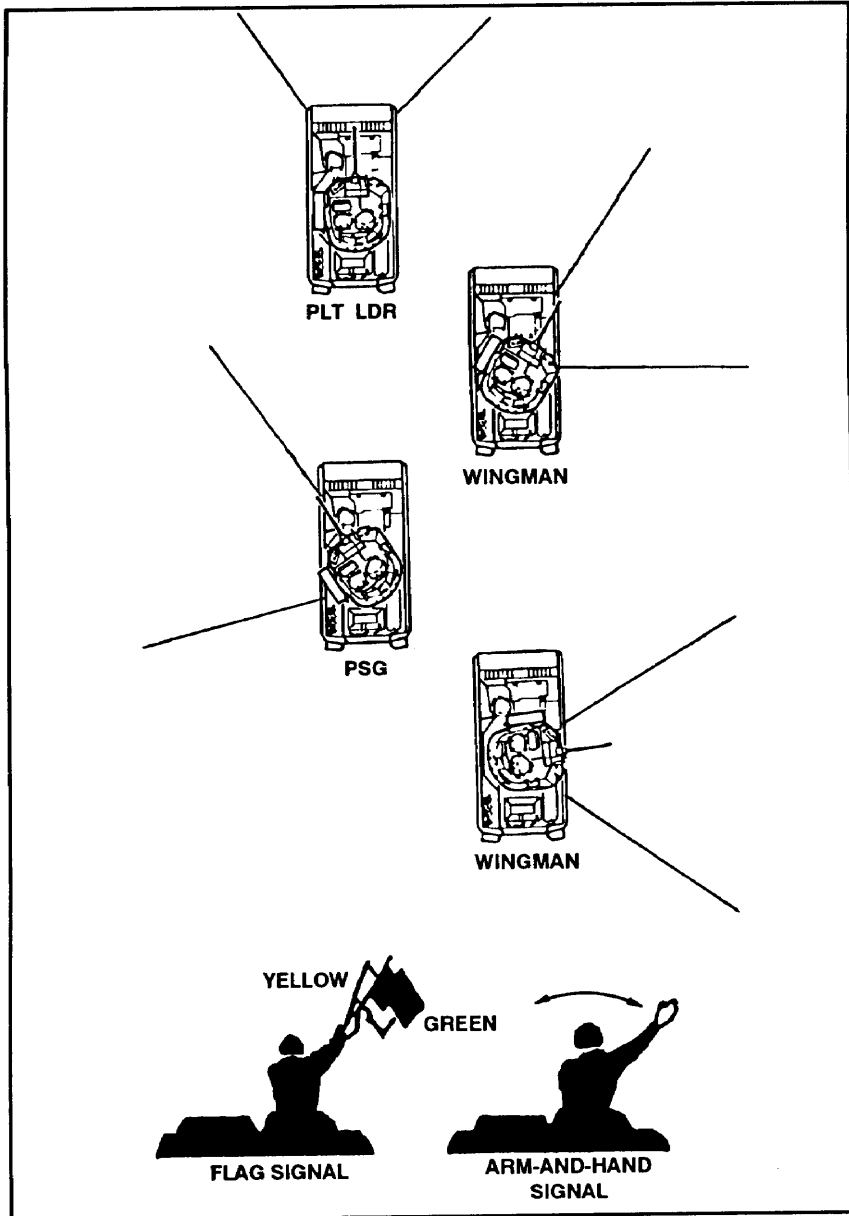

Figure 3-24. Column formation.

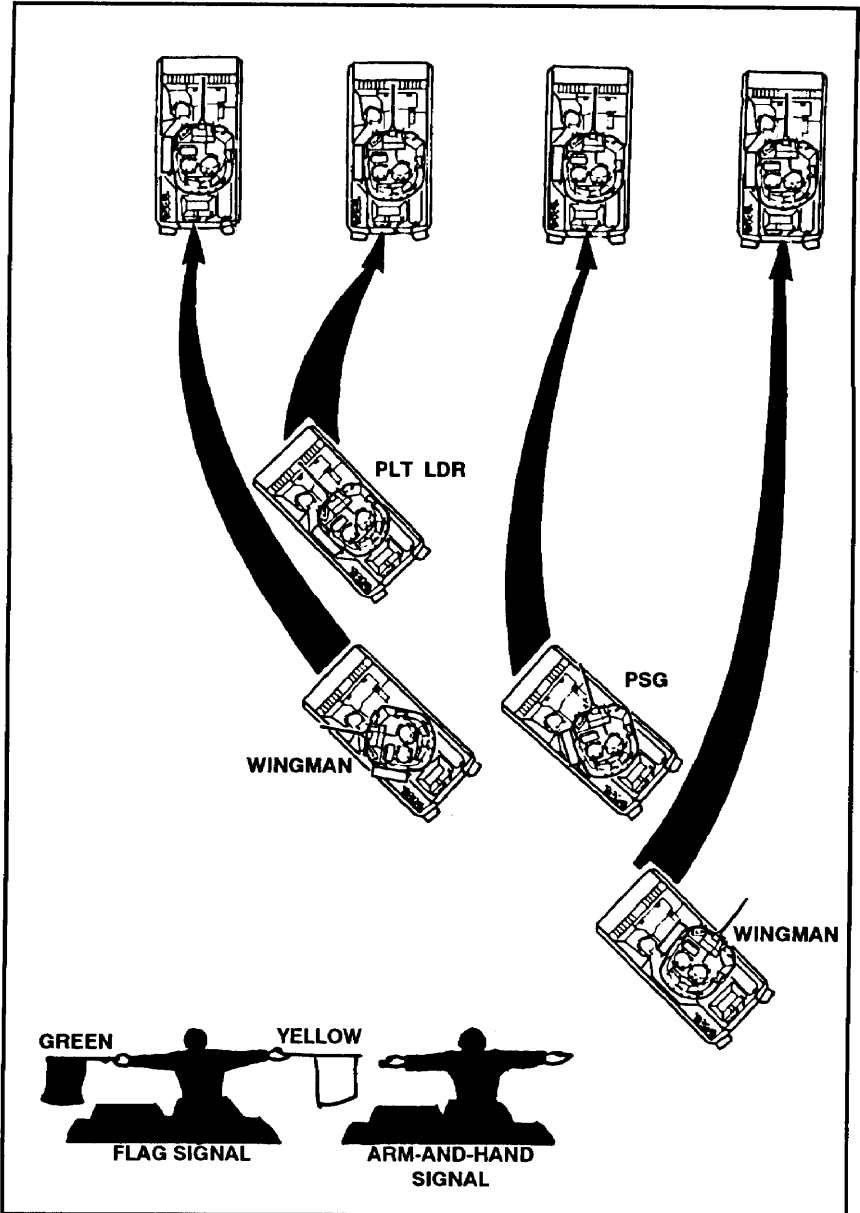

Figure 3-25. Column to line formation.

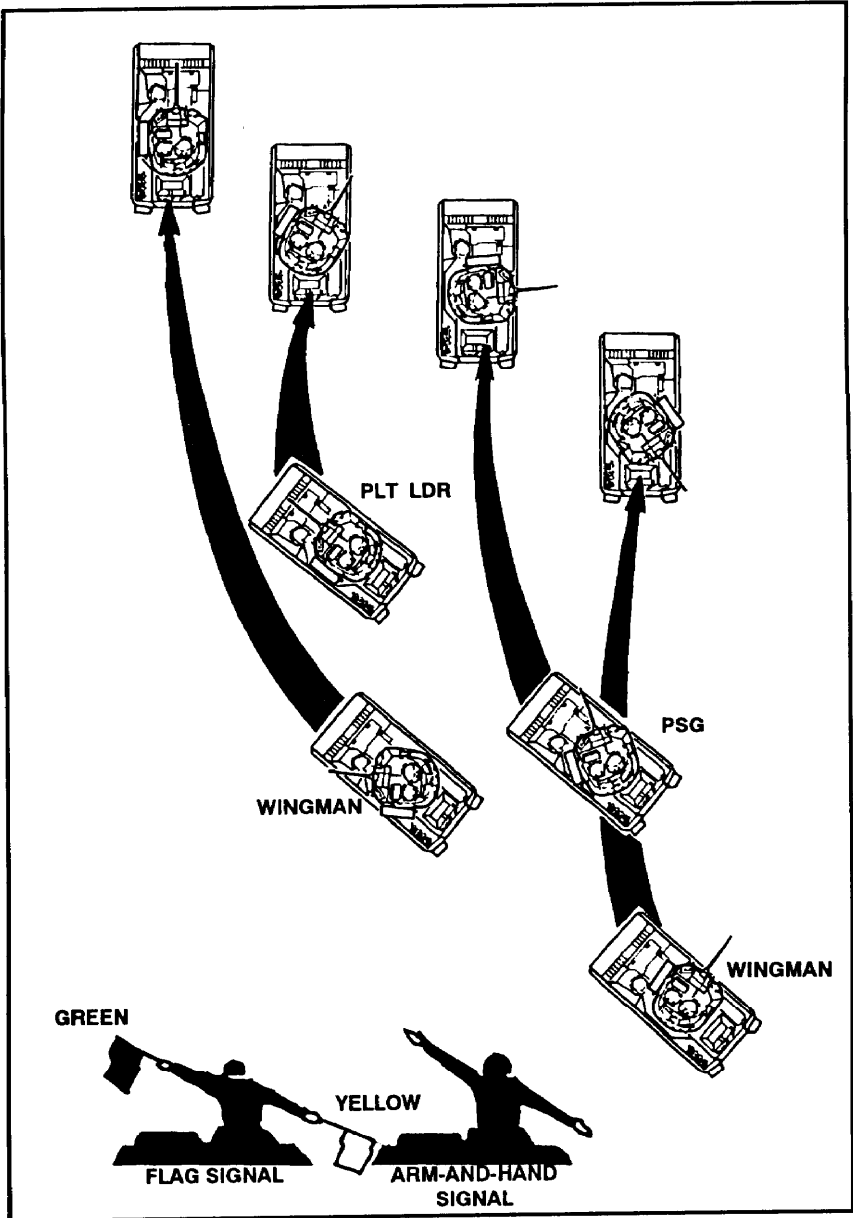

Figure 3-26. Column to echelon formation.

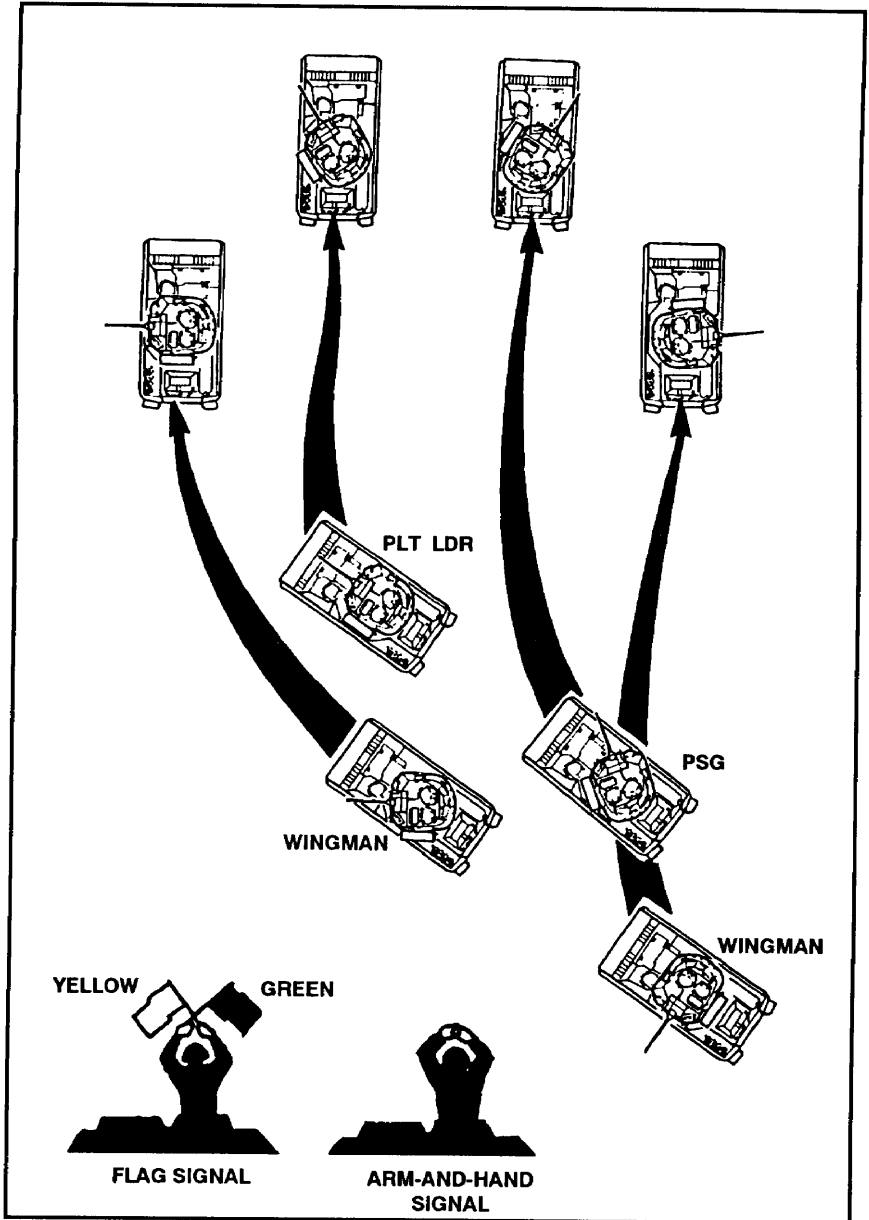

Figure 3-27. Column to wedge formation.

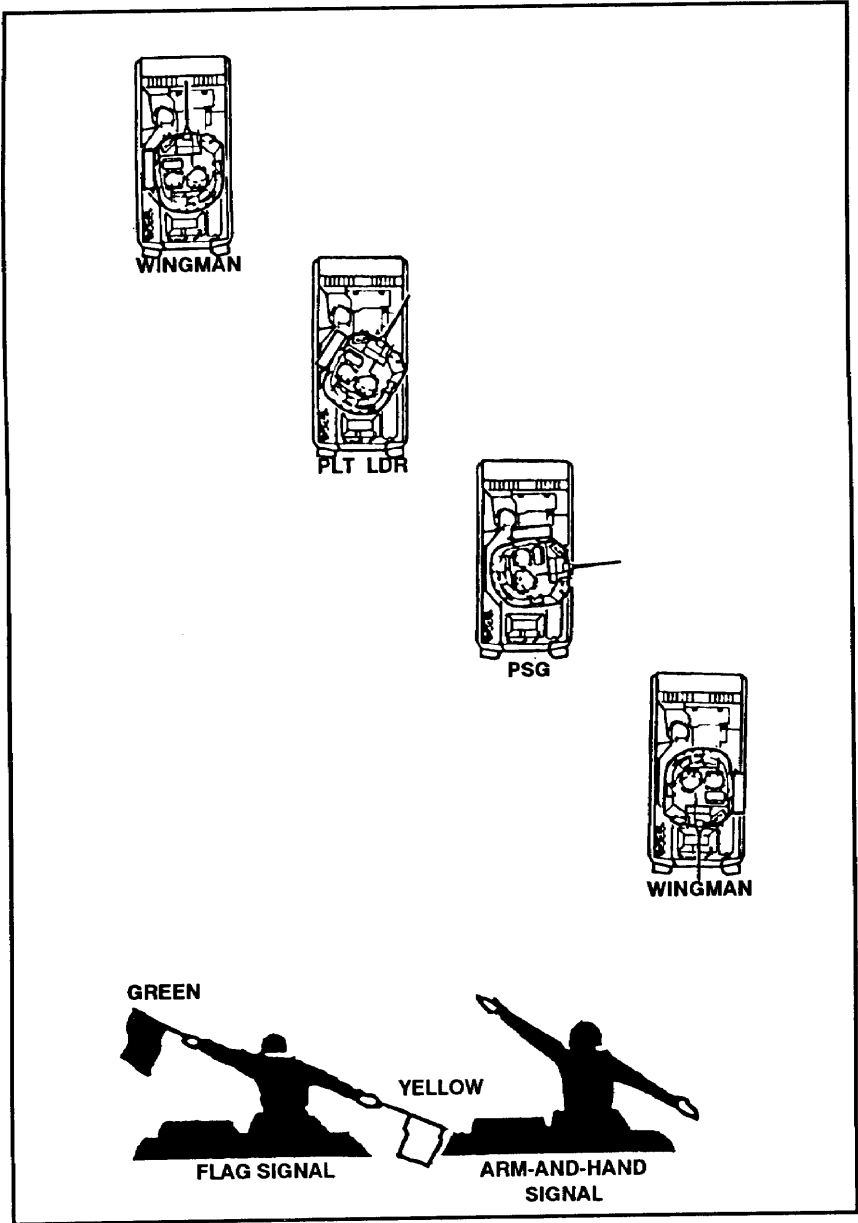

Figure 3-28. Echelon formation (right).

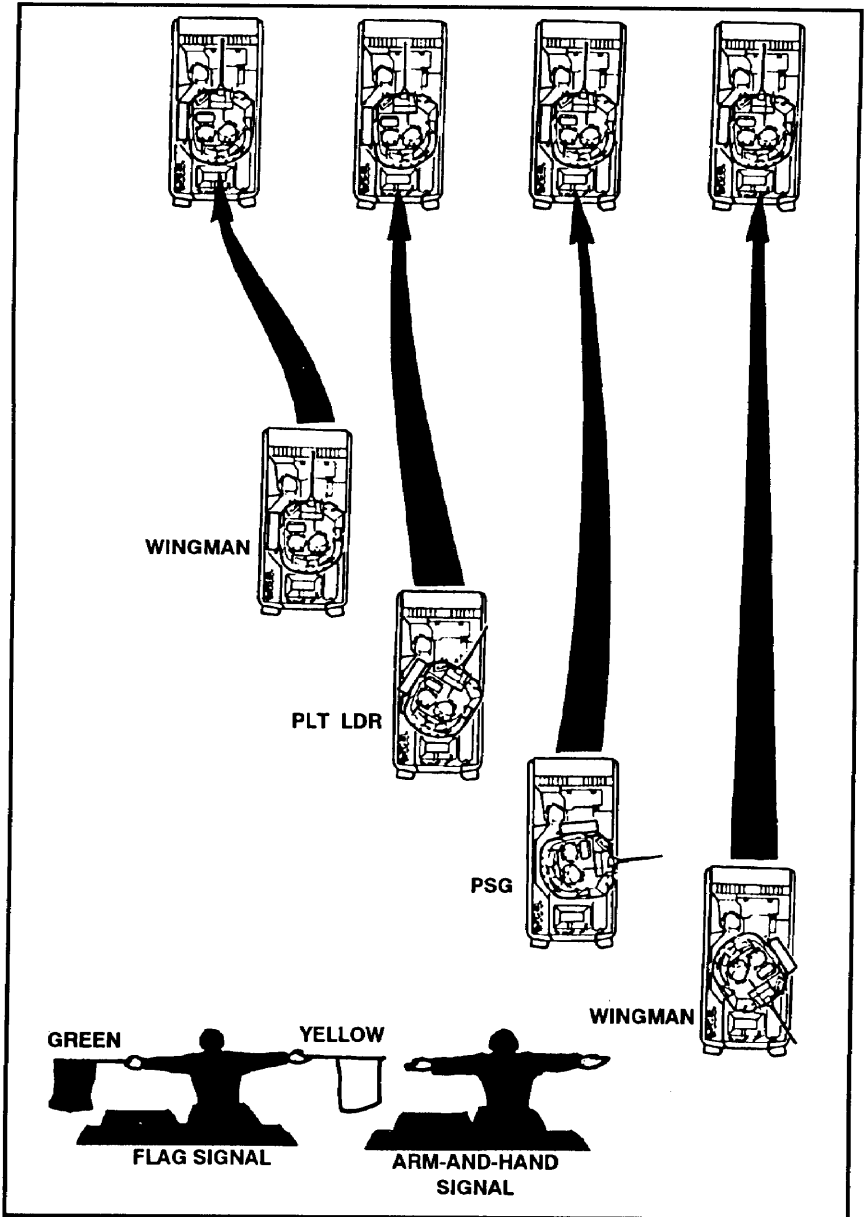

Figure 3-29. Echelon to line formation.

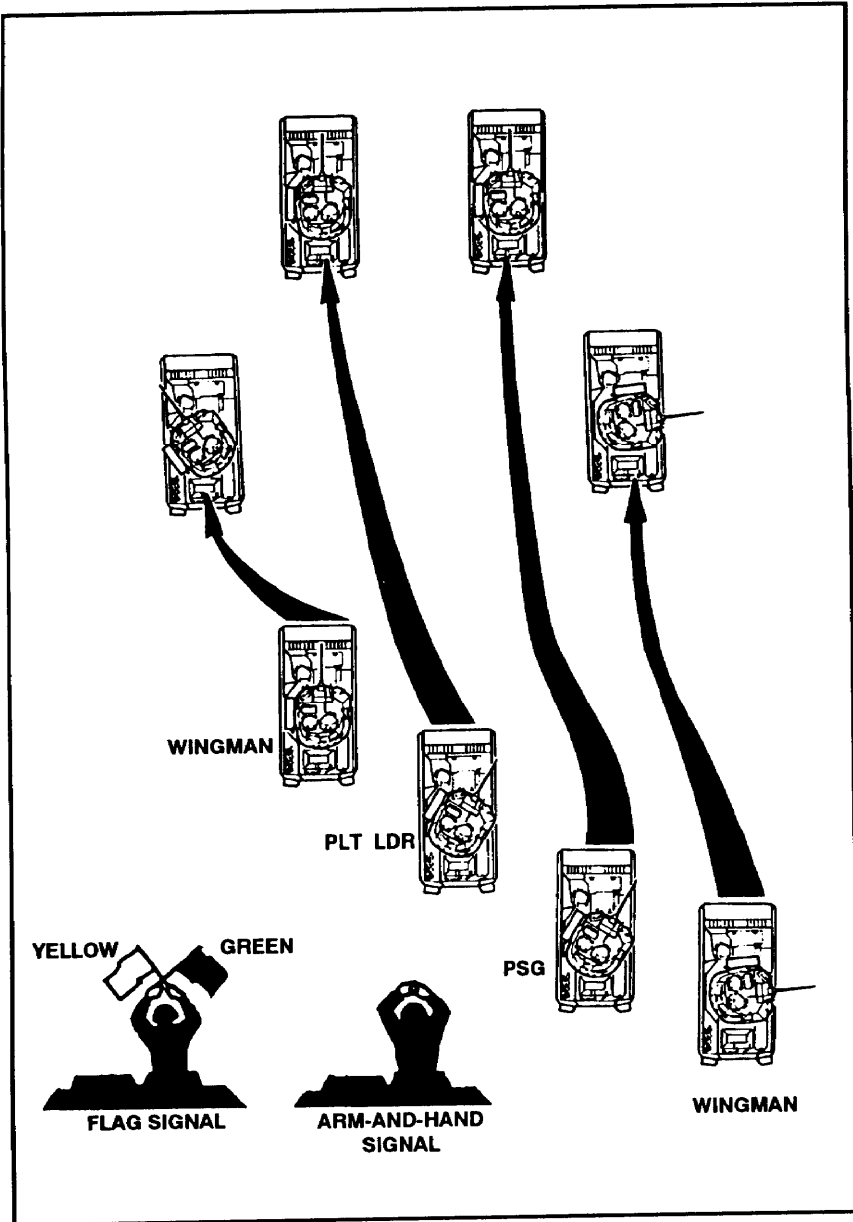

Figure 3-30. Echelon to wedge formation.

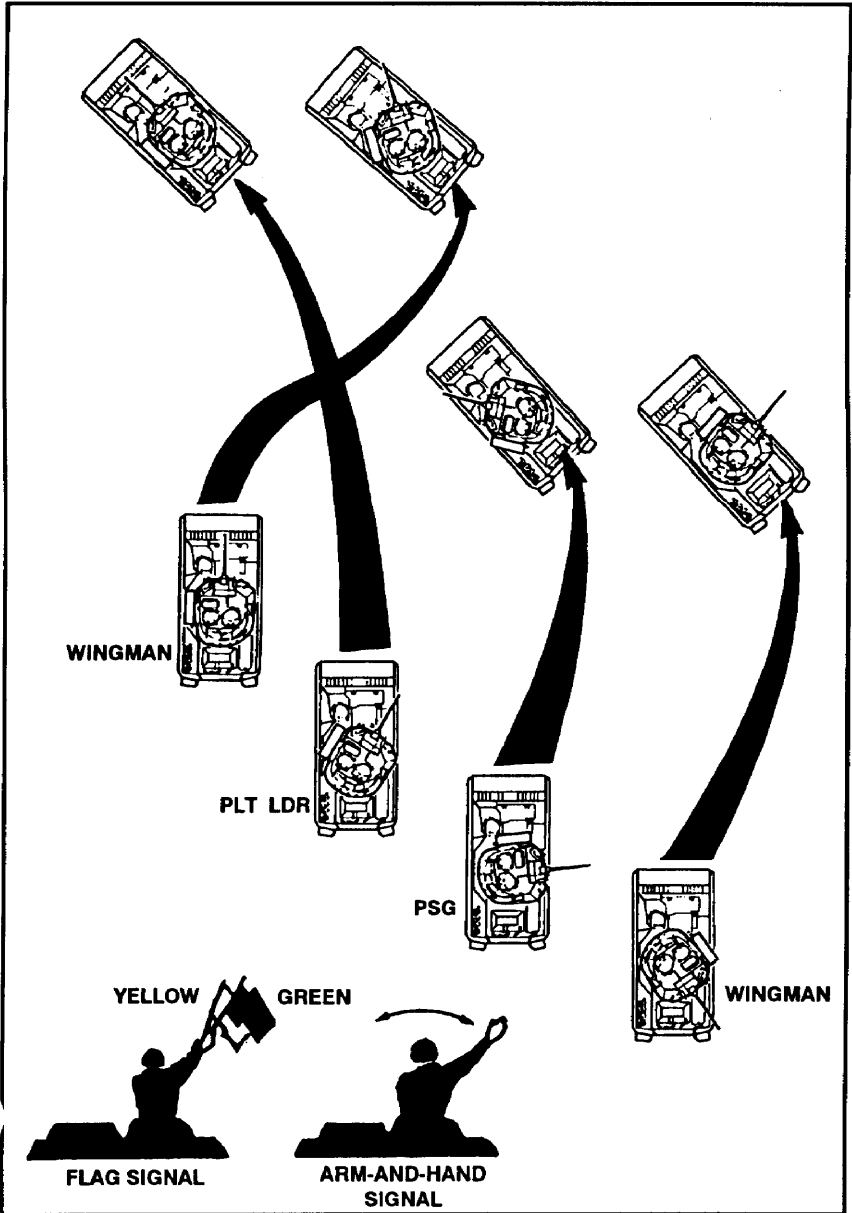

Figure 3-31. Echelon to column formation.

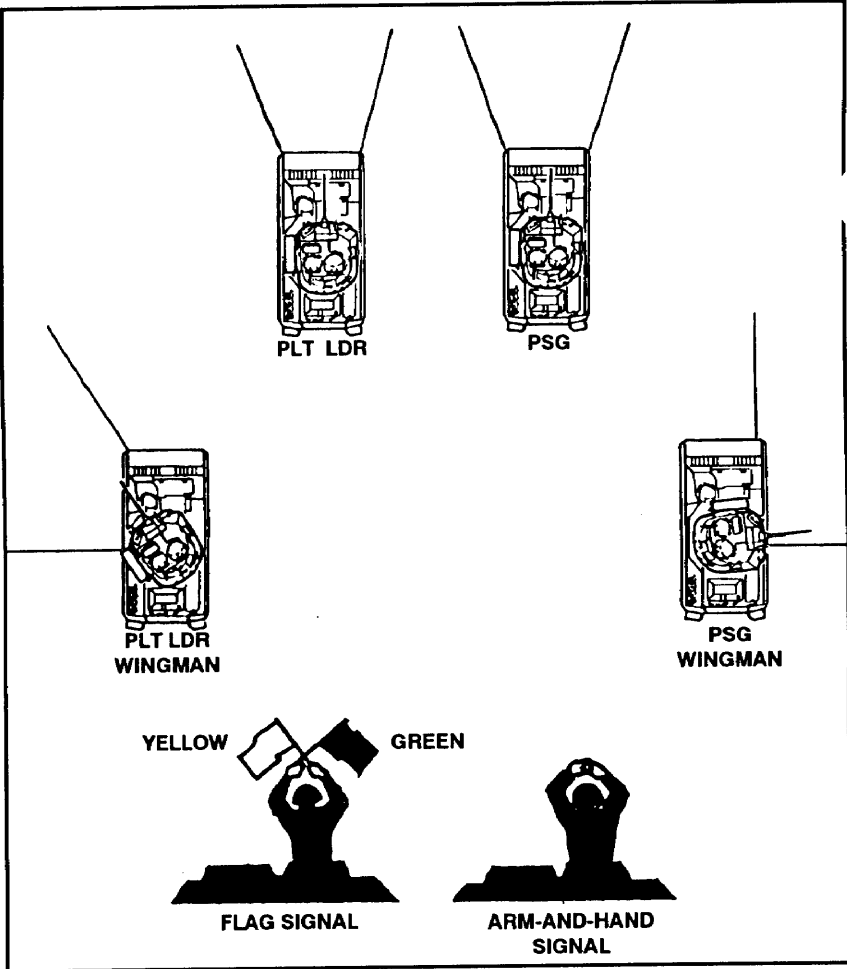

Figure 3-32. Wedge formation.

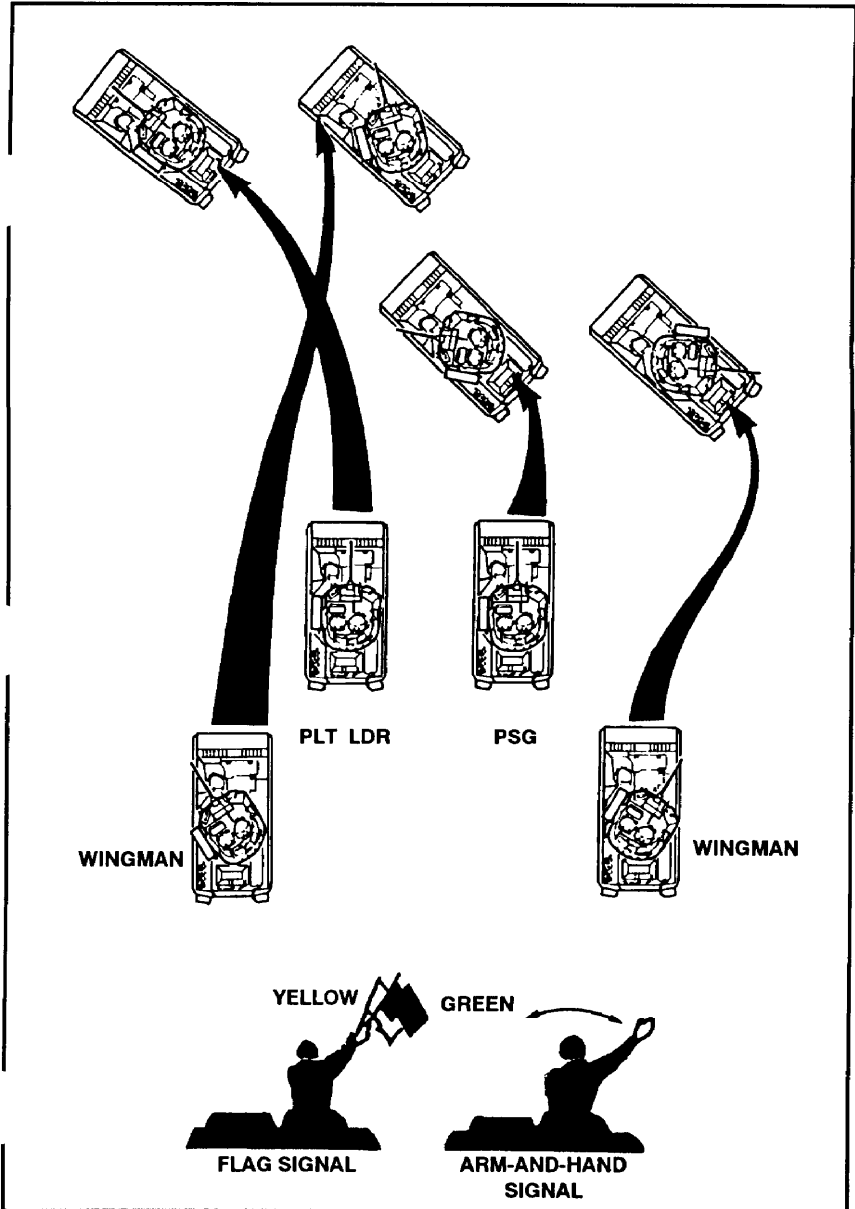

Figure 3-33. Wedge to column formation.

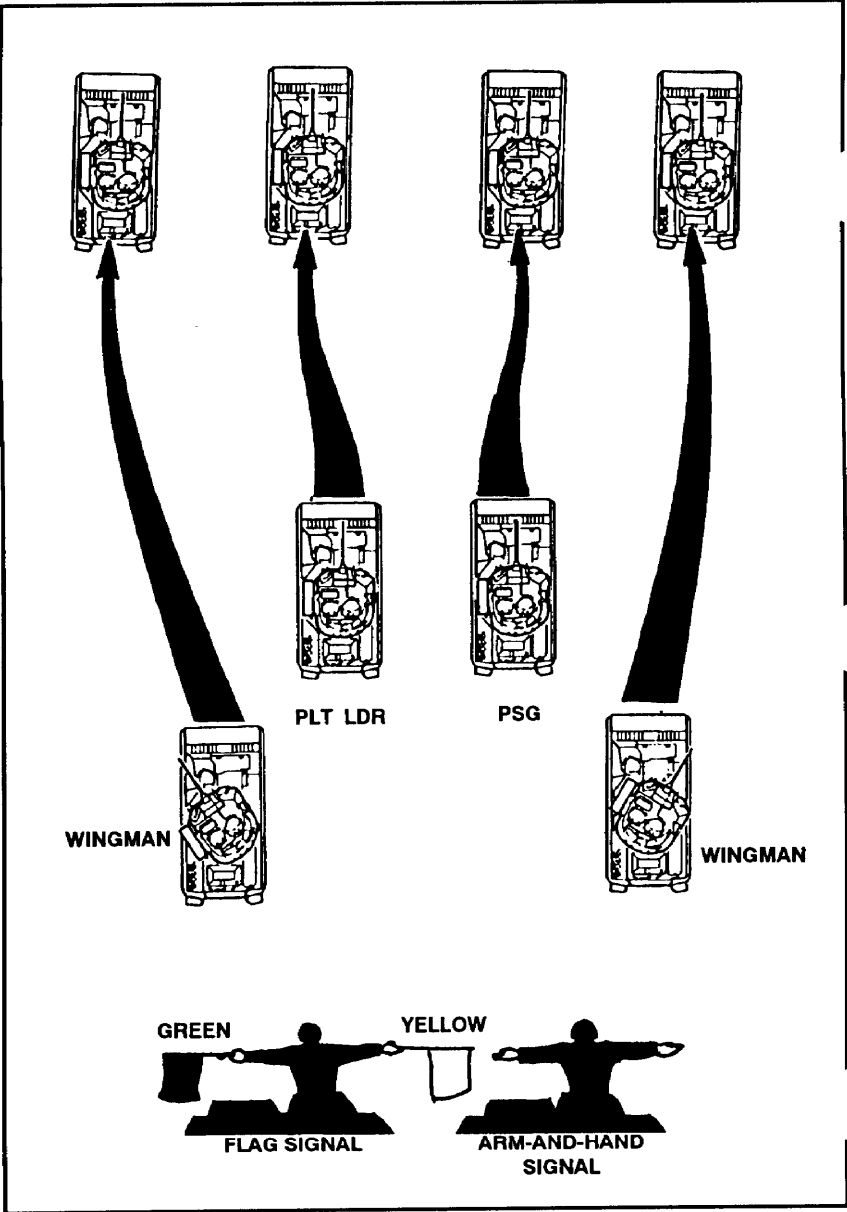

Figure 3-34. Wedge to line formation.

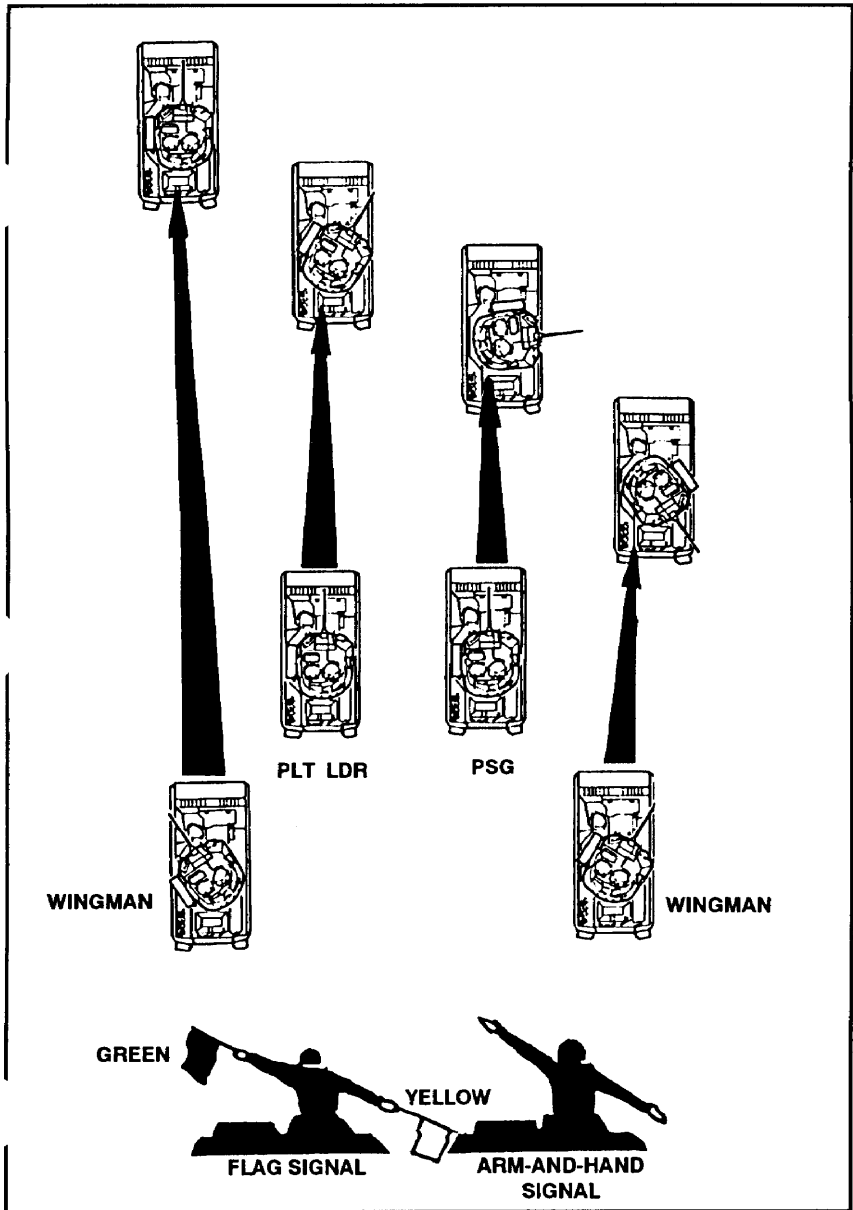

Figure 3-35. Wedge to echelon formation.

Crew Drill 7
SECURE AT THE HALT (PLATOON)

SITUATION: The platoon is moving and must halt.

REQUIRED ACTIONS: (Figures 3-36 through 3-39, pages 3-81 through 3-84.)

1. The platoon leader gives the arm-and-hand signals for herringbone or coil formation.
2. The platoon halts in the herringbone or coil formation.
3. Each BC ensures his vehicle is correctly positioned, using cover and concealment.
4. The gunner orients his turret and raises the TOW launcher and observes his sector of fire.
5. The platoon leader orders the squads to dismount and provide local security. (Dismount IAW with the task, Dismount the Vehicle.)
6. The fire team occupies a hasty fighting position as designated by the team leader in the vicinity of their respective BFV. The squad leader contacts the team leader and adjusts security positions as necessary.
7. Soldiers continue to observe designated sectors.

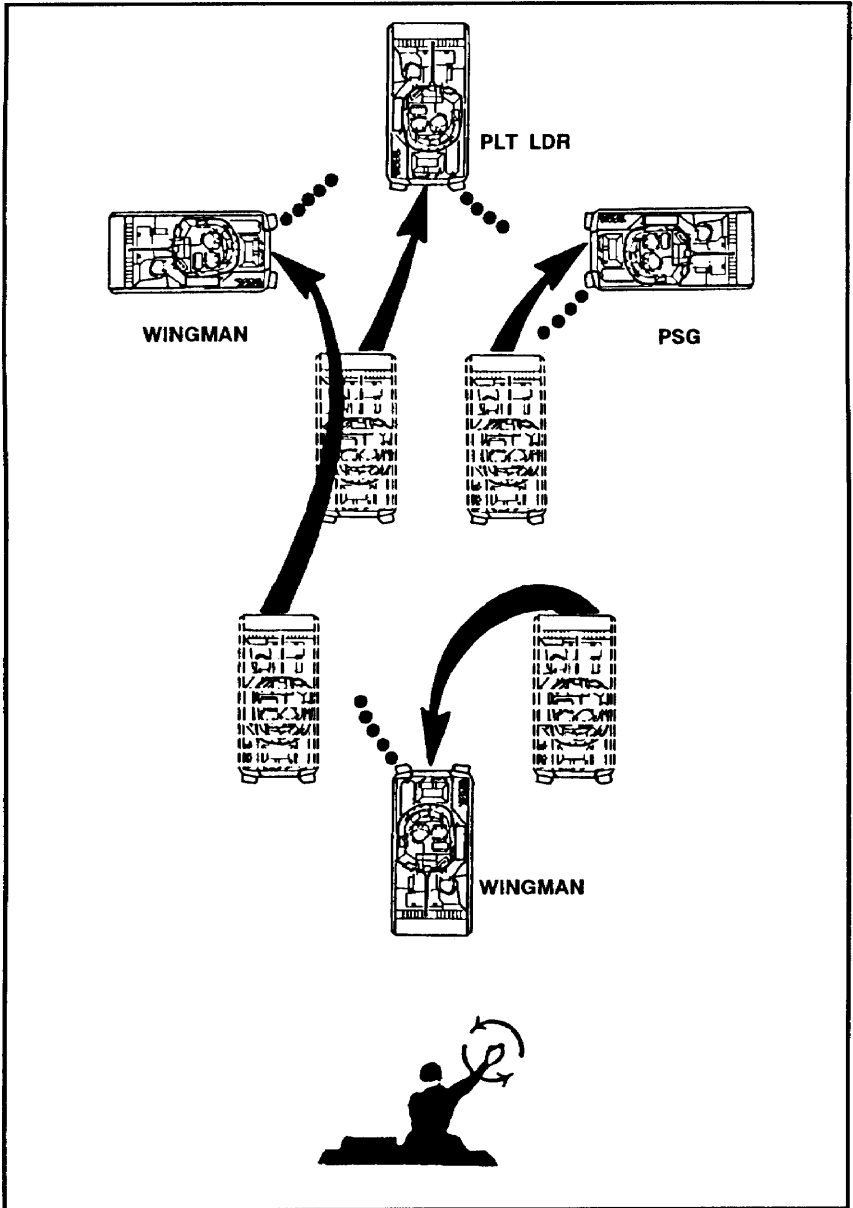

Figure 3-36. Wedge to coil formation.

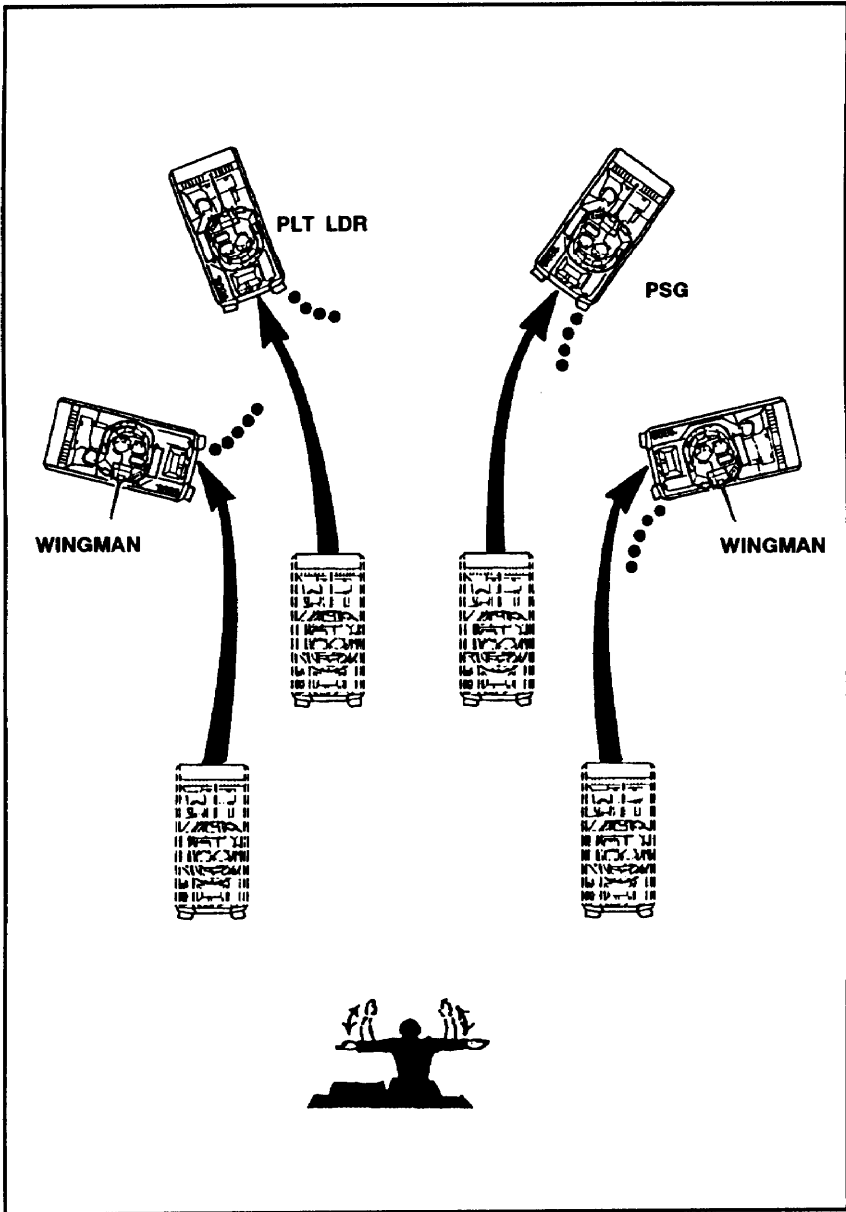

Figure 3-37. Wedge to herringbone formation.

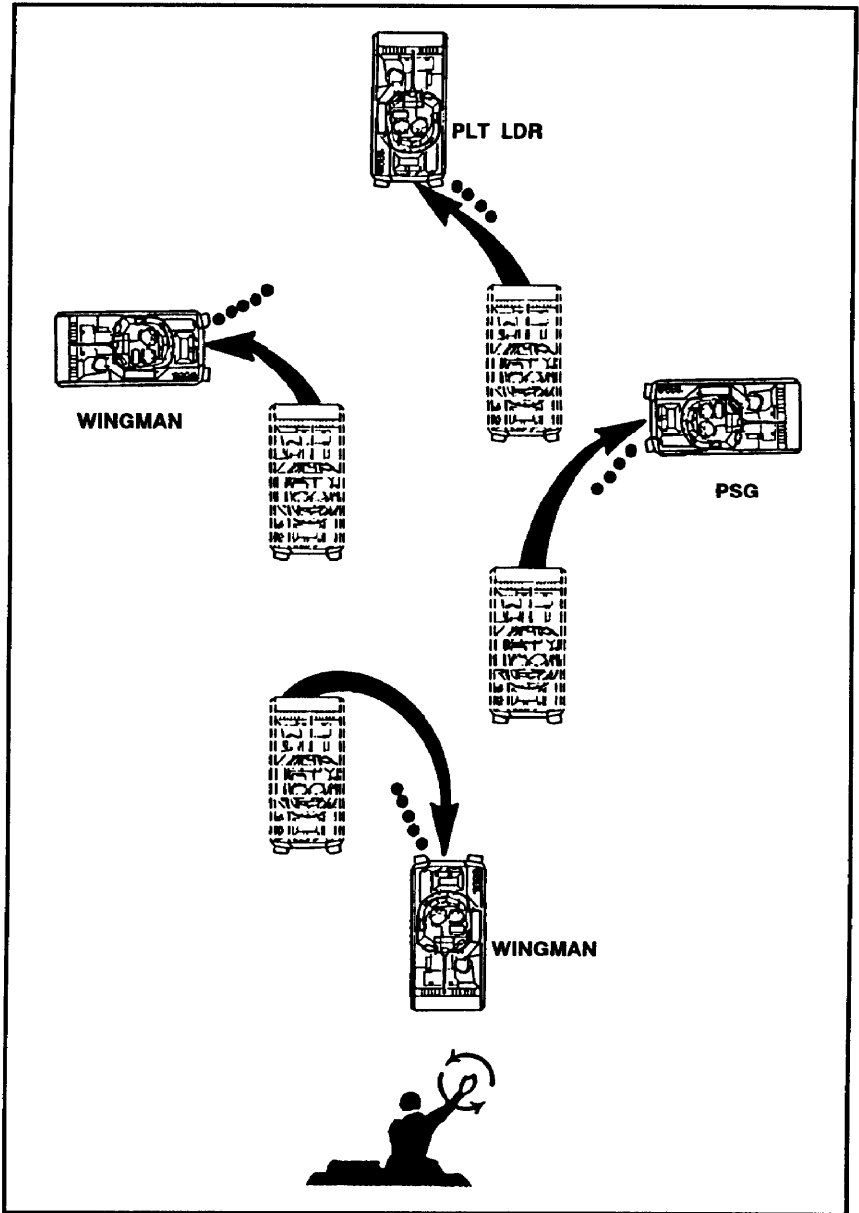

Figure 3-38. Column to coil formation.

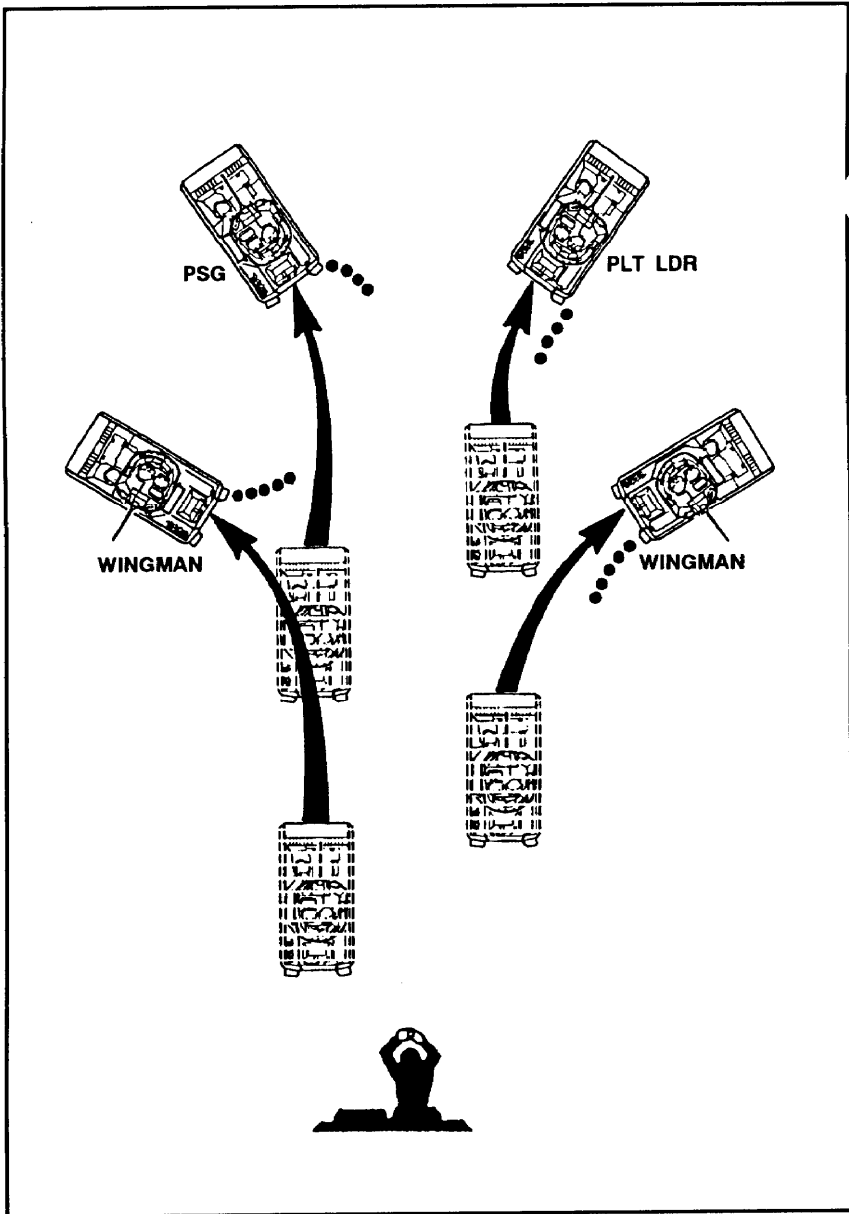

Figure 3-39. Column to herringbone formation.

Crew Drill 8
EXECUTE ACTION RIGHT OR LEFT (PLATOON)

SITUATION: The platoon is moving and must execute action right or left.

REQUIRED ACTIONS: (Figures 3-40 through 3-45, pages 3-86 through 3-91.)

1. The platoon leader signals action right or left using arm-and-hand, flags, or radio.
2. The drivers immediately execute a turn in the direction indicated while moving into a line formation.
 - The platoon sergeant orients his vehicle on the platoon leader's vehicle.
 - Wingmen orient their BFVs on the section leader's vehicles.
3. The platoon leader orders the BCs to seek covered positions for their vehicles or have them continue to move in the direction indicated.
4. The BCs orient the main weapons toward the enemy, and the BCs and gunners search for targets.
5. The platoon leader determines if it is necessary to dismount the infantry.
6. The platoon leader reports the situation to the company commander, if necessary.

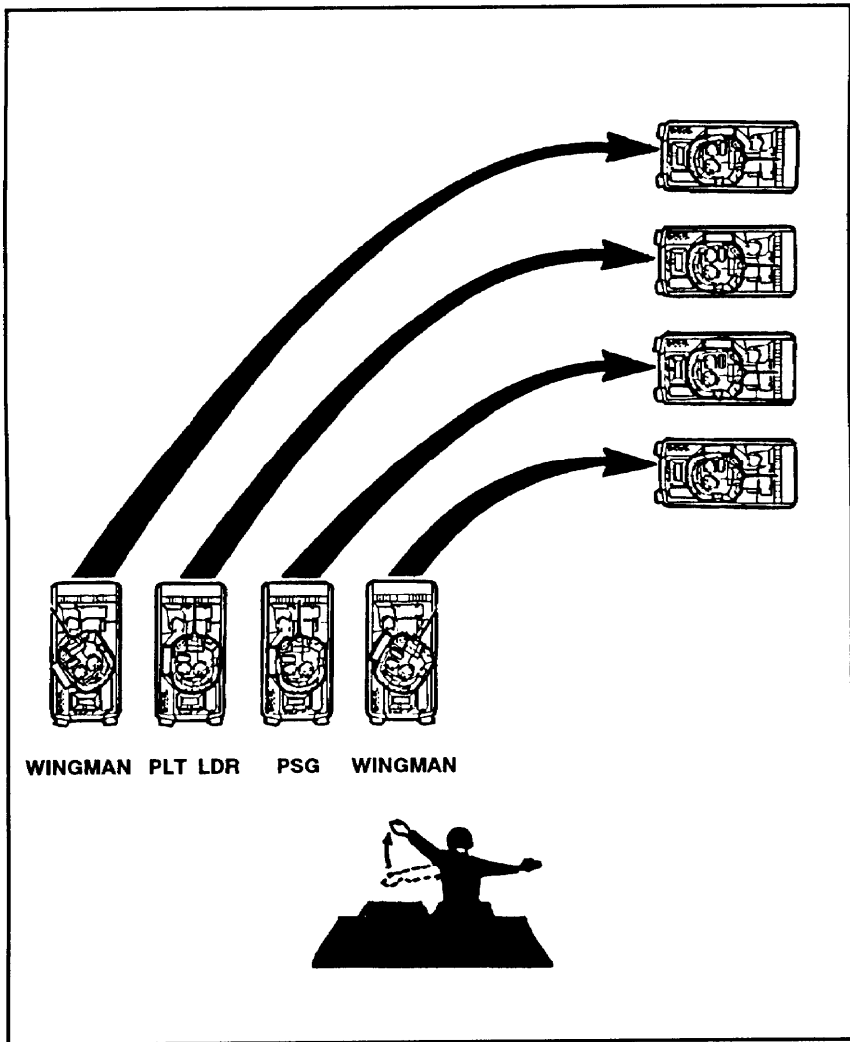

Figure 3-40. Action right from line.

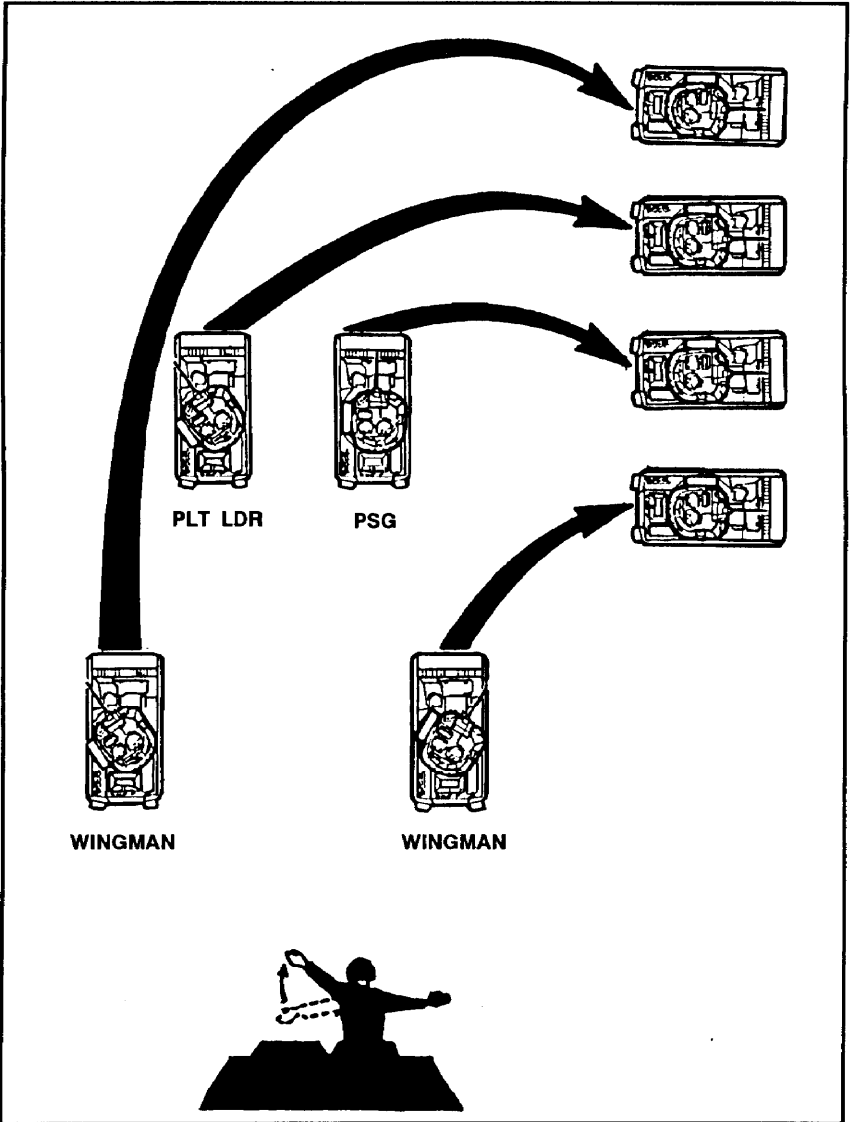

Figure 3-41. Action right from wedge.

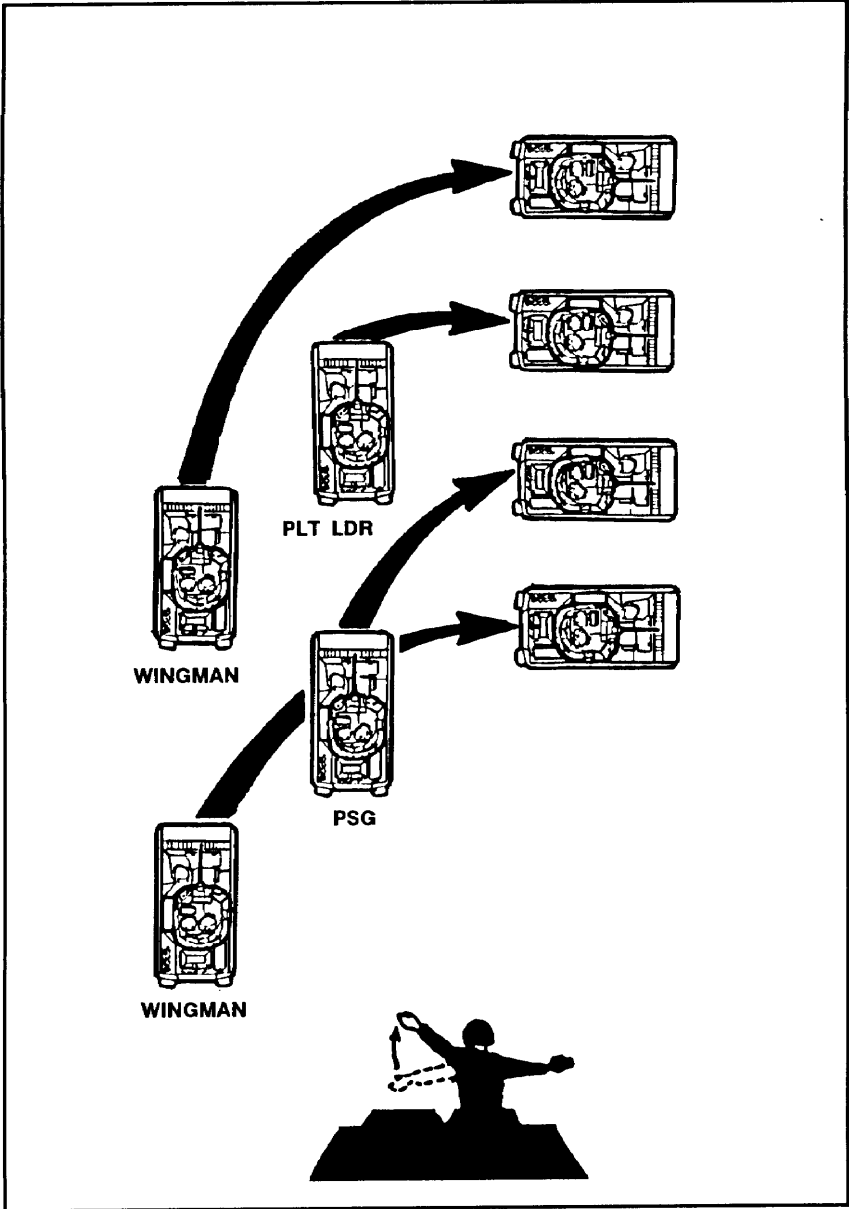

Figure 3-42. Action right from column.

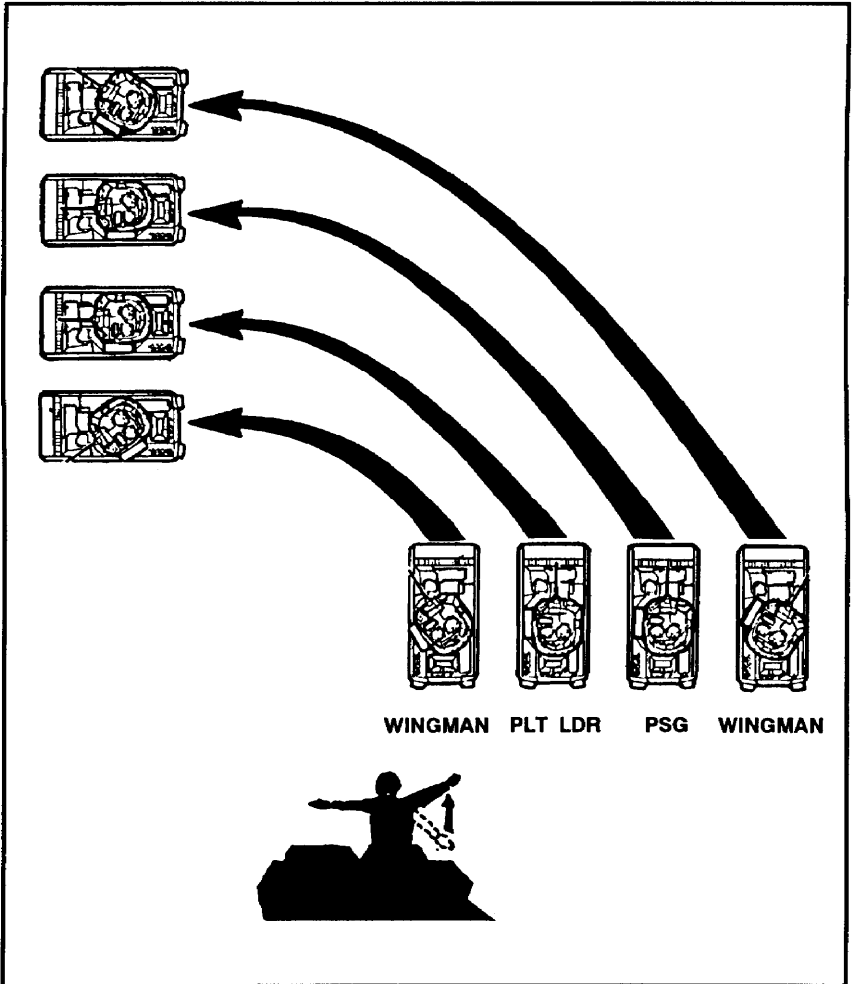

Figure 3-43. Action left from a line.

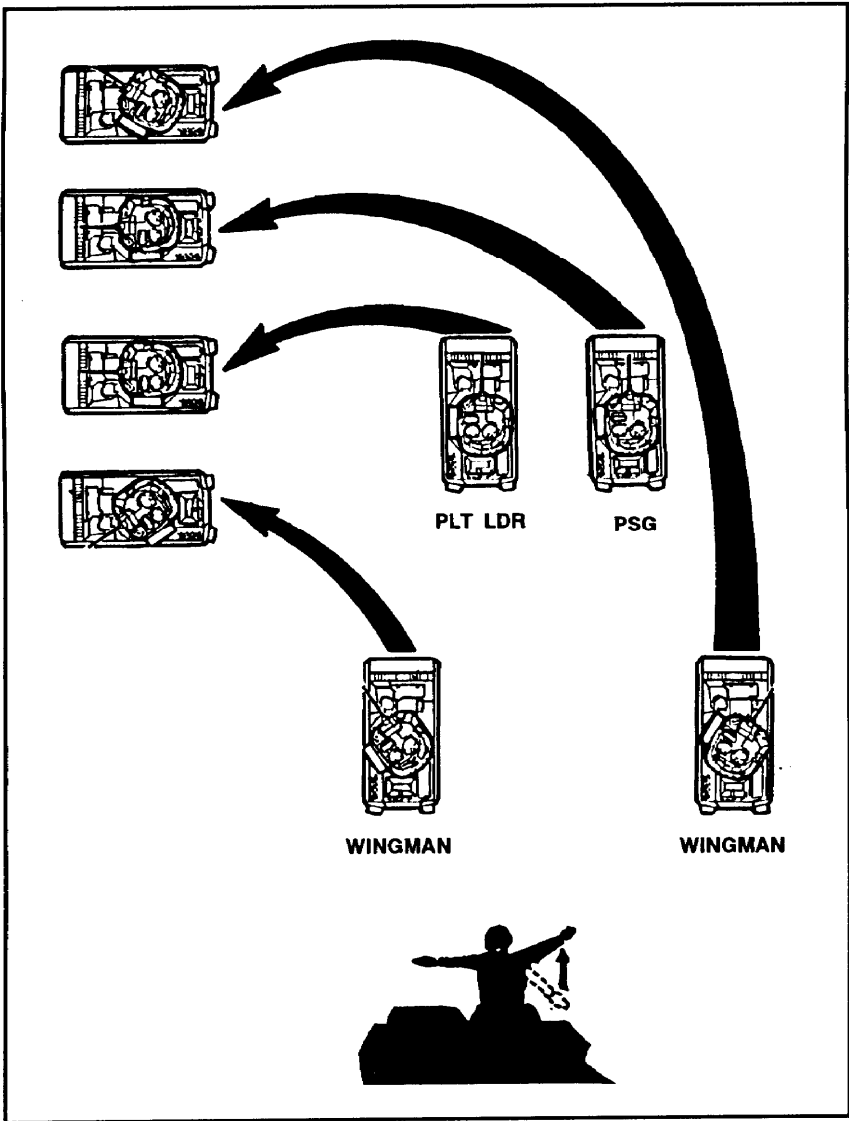

Figure 3-44. Action left from a wedge.

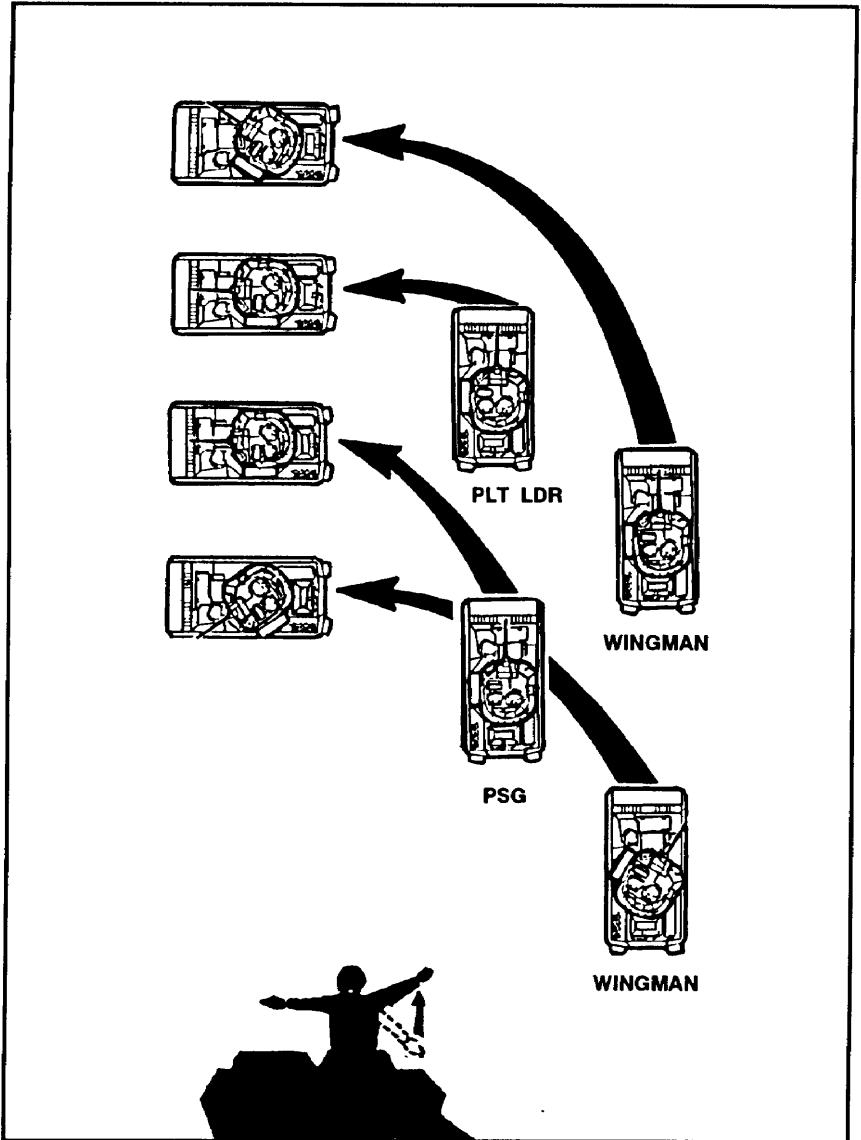

Figure 3-45. Action left from a column.

Crew Drill 9
LOAD THE 25-MM AMMUNITION READY BOX
(HE or AP)

SITUATION: During initial loading or when the low ammunition light comes on. Given a BFV with the ramp up, master power is ON, with 300 rounds of 25-mm ammunition in 30-round boxes stored in accordance with the load plan (25-mm HE or AP).

DANGER

HANDLE AMMUNITION WITH CARE. DO NOT BUMP PRIMERS AGAINST ANY HARD SURFACE. IF A CARTRIDGE EXPLODES, SOLDIERS COULD BE KILLED OR HURT.

REQUIRED ACTIONS:

Load the 25-mm HE Ammunition

1. **Gunner:** Moves the turret to HE load (2150 mils), announces when he has set the turret travel lock.

DANGER

BC MUST TURN OFF THE TURRET DRIVE SYSTEM BEFORE THE TURRET SHIELD DOOR IS OPENED. SOLDIERS COULD BE KILLED OR HURT.

2. **Bradley Commander:**

a. Instructs the driver to lower the ramp. BC announces, **UPLOAD HE READY BOX.**

b. Sets the turret drive switch to the OFF position.

NOTE: In the absence of a fire team member, the BC performs the following duties.

3. **Fire Team Member:** The fire team member sitting in the No. 9 seat performs the duties of the loader.

a. Opens the turret shield door.

b. Opens and removes the door from the HE ammunition can.

c. Stows squad seats and removes the floor plates.

d. Prepares the HE ammunition for loading.

CAUTION

Rounds not aligned properly can cause jamming in the 25-mm ammunition can and chutes. Rounds must be aligned at the tips. Severe damage to the feeding system could result if the ammunition is not aligned.

- (1) Unstows the HE ammunition.
- (2) Conducts a quick visual inspection to ensure it is serviceable, clean, and aligned.

CAUTION

Links may be damaged if rounds are not removed correctly. If a round does not release from a link, stop pulling on the round. To free a round from a link, twist and pull up on the round at the same time. Bent links can jam the feeder.

- (3) If loading an empty can, joins 15-round ammunition belts and loads 30 rounds at a time until there are 230 rounds loaded into the HE ammunition-ready can.

CAUTION

The end of the ammunition belt with the double links always goes in the ammunition can first. The end of the ammunition belt with the empty single link goes in last. If the ammunition is not loaded correctly, ammunition will bind in the chutes and damage the equipment.

NOTE: An ammunition belt must be loaded with the links on the top and the rounds pointed to the right of the vehicle. Count the rounds as they are loaded.

- (4) If reloading, checks to see how many rounds are remaining in the ammunition can. There must be a single empty link at the end of the ammunition belt.

- e. Loads the first 44 rounds in the ammunition can.

- f. Turns the ammunition belt over so that the links are on the top. Rounds should point to the right of the vehicle.

- g. Counts the 5th and 19th rounds. Feeds the ammunition belt with the double links first into the ammunition can. Hangs the first five rounds on the loading rail. Hangs the 19th round on the loading rail.

- h. Counts the next 25 rounds. Hangs both the 24th and 25th rounds on the loading rail.

4. **Gunner:** Releases the upper roller to the rear of the ammunition can.
 - a. Forwards the rounds with the 14-mm ratchet wrench.
 - b. Locks the upper roller.
5. **Fire Team Member:** Loads the remainder of the rounds in the ammunition can. Hangs every 24th and 25th round.
6. **Gunner:** Lifts the ammunition belt loops over the baffles.
7. **Fire Team Member:** Installs and closes the HE ammunition can door.
 - a. Ensures the HE-AP selector switch is set to HE.
 - b. Closes the turret shield door, and taps on the shield door and announces, HE UPLOADED.
 - c. Stows empty ammunition boxes.
 - d. Replaces floor plates and unstows seats.

Load the 25-mm AP Ammunition

8. **Gunner:** Moves the turret to AP load (4350 mils). Announces when he has set the turret travel lock.

DANGER

BC MUST TURN OFF THE TURRET DRIVE SYSTEM BEFORE THE TURRET SHIELD DOOR IS OPENED. SOLDIERS COULD BE KILLED OR HURT.

9. **Bradley Commander:**
 - a. Instructs the driver to lower the ramp. Announces, UPLOAD AP READY BOX.
 - b. Sets the turret drive switch to the OFF position.

NOTE: In the absence of a fire team member, the BC performs the following duties.

10. **Fire Team Member:** The fire team member sitting in the No. 9 seat performs the duties of the loader.
 - a. Opens the turret shield door.
 - b. Opens and removes the door from the AP ammunition can.
 - c. Stows squad seats and removes the floor plates.
 - d. Prepares the AP ammunition for loading.

CAUTION

Rounds not aligned properly can cause jamming in the 25-mm ammunition can and chutes. Rounds must be aligned at the tips. Severe damage to the feeding system could result if the ammunition is not aligned.

- (1) Unstows the AP ammunition.
- (2) Conducts a quick visual inspection to ensure it is serviceable, clean, and aligned.

CAUTION

Links may be damaged if rounds are not removed correctly. If a round does not release from a link, stop pulling on the round. To free a round from a link, twist and pull up on the round at the same time. Bent links can jam the feeder.

- (3) If loading an empty can, joins and loads the ammunition in 30-round belts until 70 rounds are loaded into the AP ammunition can.

CAUTION

The end of the ammunition belt with the double links always goes in the ammunition can first. The end of the ammunition belt with the empty single link goes in last. If the ammunition is not loaded correctly, ammunition will bind in the chutes and damage the equipment.

NOTE: An ammunition belt must be loaded with the links on the top and the rounds pointed to the left of the vehicle. Count the rounds as they are loaded.

- (4) If reloading, checks to see how many rounds are remaining in the ammunition can. There must be a single empty link at the end of the ammunition belt.

- d. Counts the first 26 rounds. Hangs the first round onto the load rail, then hangs the 25th and 26th rounds onto the loading rail.

- e. Lifts the single linked end of the ammunition belt up into the forwarder. Pushes the last round until it is engaged in the sprocket.

11. **Gunner:** Releases the upper roller to the rear of the ammunition can.

- a. Forwards the rounds with the 14-mm ratchet wrench.

- b. Locks the upper roller.

12. **Fire Team Member:**

- a. Installs and closes the AP ammunition can door.

- b. Ensures the HE-AP selector switch is set to AP.

- c. Closes the turret shield door, taps on the shield door, and announces, AP UPLOADED.

- d. Stows empty ammunition boxes.

- e. Replaces floor plates and unstows squad seats.

Crew Drill 10
ENGAGE TARGETS WITH THE 25-MM AUTOMATIC
GUN OR 7.62-MM COAX (CREW)

SITUATION: Upon recognition of a target or on the BC's order. With the ISU, the Bradley crew has identified a target.

REQUIRED ACTIONS:

1. **Bradley Commander:** Lays the gun for direction by squeezing the palm switch on the commander's handstation and turning the turret in the general direction of the target. The BC issues a battlesight or precision fire command.

2. **Gunner:**

- a. Indexes the announced range into the ISU.
- b. Selects the ammunition/weapon system on the weapon control box in accordance with the BC's fire command.
- c. Acquires the target using the ISU on low power.
- d. Switches to the HIGH magnification and announces IDENTIFIED.

(1) If the gunner announces "Cannot identify," the BC attempts to identify and gives further instructions.

(2) If the gunner announces "Lost," the BC gives additional target location information.

(3) If the gunner announces "Friendly," the BC gives a new target location or takes the weapon out of action.

(4) If the gunner announces "Cannot engage," the BC designates another target or tells the driver to move the vehicle (for example, "Driver, back, right, stop").

- e. Lays the reticle on the center of target visible mass.

3. **Bradley Commander:** Commands FIRE.

4. **Gunner:** Announces ON THE WAY, and fires the weapons system.

5. **Bradley Commander:** Commands CEASE FIRE, upon target destruction to end the engagement.

Crew Drill 11

RELOAD A TOW LAUNCHER (CREW)

SITUATION: The BFV has fired two TOW missiles and needs to be reloaded. The TOW casings are in the launch tubes. The TOW launcher is raised.

REQUIRED ACTIONS:

1. **Bradley Commander:** Commands PREPARE TO LOAD MISSILE
2. **Gunner:**
 - a. Traverses the turret to the TOW LOAD position (5950 mils).
 - b. Moves the ARM-SAFE-RESET switch to RESET then to the SAFE position.
 - c. Elevates the launcher to 500 mils.
3. **Bradley Commander:** Moves the turret drive switch to OFF.
4. **Gunner:** Engages the turret travel lock.
5. **Fire Team Member:** The fire team member in the No. 5 seat is responsible for reloading the TOW missiles.

NOTE: In the absence of the dismounted soldiers, the BC acts as the loader, depending on the unit's SOP. In the absence of the BC, the gunner assumes the responsibilities of the BC.

- a. Unstows the missiles.
- b. Checks the humidity indicator(s) on the stowed missile. (If the humidity indicators are pink, do not use.)
- c. Inspects the containers for damage.
- d. Removes the forward handling rings from the nose end of the stowed missiles.
- e. Removes the electrical connector covers from the stowed missiles.
- f. Checks the nose ends and rear diaphragms.
6. **Bradley Commander:** Commands LOAD MISSILE.
7. **Fire Team Member:**
 - a. Leader announces, UPLOADING TOW.
 - b. Opens the cargo hatch cover to the TOW LOAD position.
 - c. Pushes the release button on the side of the locking handle and pulls down.
 - d. Removes the expended missiles.
 - e. Ensures the umbilical connectors do not extend down into the TOW launcher.
 - f. Loads the missiles into the launcher (outside tube first).
 - g. Holds the missile and pushes the locking handle up until it locks.

- h. Closes the cargo hatch.
- i. Announces, TOW UPLOADED.

8. Gunner:

- a. Turns the turret drive switch to ON and disengages the turret travel lock.
- b. Traverses the turret to the target area and arms the system.

Crew Drill 12

ENGAGE TARGETS WITH THE TOW (CREW)

SITUATION: The Bradley crew has identified a target for the TOW within 3,750 meters.

REQUIRED ACTIONS:

1. **Bradley Commander:** Commands GUNNER, MISSILE, TANK, and lays the gun for direction to the target.
2. **Gunner:** Starts searching for the target as the BC lays the gun.
3. **Driver:** Halts the vehicle in a hull-down position.
4. **Gunner:** Selects HIGH MAG and uses the ISU to determine if the target is engageable.
5. **Driver:** Checks the vehicle slope indicator to ensure the vehicle is within the 10-degree slope warning.
6. **Gunner:** Checks the vehicle slope indicator to ensure the vehicle is within the 10-degree slope warning. Places the launcher's UP-DOWN switch on the TOW control panel to UP.
 - a. Depresses the gunner's palm switch to raise the launcher.
 - b. Depresses the TOW button on the TOW control panel.
 - c. Selects the missile tube one or two on the TOW control panel.
 - d. Places the arm-safe-reset switch to ARM.
 - e. Sights the target, announces, IDENTIFIED, and lays the cross hairs on the center of target visible mass.
 - (1) If the gunner announces "Cannot identify," the BC attempts to identify and gives further instructions.
 - (2) If the gunner announces "Lost," the BC gives additional target location information.
 - (3) If the gunner announces "Friendly," the BC gives the new target description or takes the weapon out of action.
 - (4) If the gunner announces "Cannot engage," the BC designates another target or tells the driver to move the vehicle (for example, "Driver, back, right, stop").
7. **Bradley Commander:** On hearing "Identified," commands FIRE.
8. **Gunner:** On hearing "Fire," announces ON THE WAY, and fires.

Crew Drill 13 REMOVE A MISFIRED TOW (CREW)

SITUATION: With all hatches closed, a TOW launcher raised to the firing position, and a misfired TOW. Immediate action has already been performed, or on order from the BC.

REQUIRED ACTIONS:

1. Gunner:

- a. Announces TOW MISFIRE, and indicates the missile that did not fire.
- b. Moves the arm-safe-reset switch to RESET, then to SAFE.
- c. Ensures that stabilization switch is set to ON to keep the weapon pointed downrange while the driver rotates the vehicle.

2. Bradley Commander: Directs the driver to seek a covered or hull-down position.

3. Driver: Pivot steers the vehicle, either left or right, in accordance with the BC's instructions. Turret remains pointed downrange.

4. Bradley Commander:

- a. Tells the driver to pivot until the turret is at 1600 or 4800 mils.
- b. Engages the turret travel lock.
- c. Moves the turret drive system switch and turret power switch to OFF.

5. Fire Team Members:

- a. Two fire team members dismount to the rear of the vehicle.
- b. One fire team member climbs onto the vehicle from the left side, keeping away from the front and rear of the vehicle.
- c. Removes the misfired TOW from the launcher.
- d. Hands the misfired missile to the fire team member on the ground.
- e. Carries the missile a safe distance away from the vehicle. Marks the missile's location.
- f. Lays the missile so that the backblast area is least destructive (minimum 200 meters).
- g. Puts a clearly visible stake and yellow flag at the misfired TOW location.

6. Bradley Commander: Notifies the chain of command of the existence and location of the misfired TOW.

Crew Drill 14
LOAD, UNLOAD, AND STOW GRENADES FOR THE
M257 SMOKE GRENADE LAUNCHER (CREW)

SITUATION: On order of the BC, the crew loads the eight smoke grenades stowed in the smoke grenade storage bins.

REQUIRED ACTIONS:

1. **Gunner:** Traverses the turret to the 6400-mil position and sets the turret travel lock.

2. **Bradley Commander:** Turns the turret drive system switch and the turret power switch to OFF.

3. **Driver:** Ensures that the master powers witch is OFF.

4. **Bradley Commander:** Commands LOAD SMOKE GRENADES.

5. **Bradley Commander or Gunner:**

a. Exits the turret from the gunner or BC hatch.

b. Removes expended grenades from the launcher.

c. Checks each launch tube for damage and debris.

d. Lifts the grenades (four) from the stowage bin and inspects the grenades.

e. Loads the launcher by sitting on the stowage bin and straddling the launcher.

f. Loads the grenades, metal end down, from bottom to top. Gently push on the smoke grenade until two clicks are felt, then turns it one-half turn.

g. Assumes the assigned seat in the turret.

6. **Bradley Commander:** Commands UNLOAD THE SMOKE GRENADE LAUNCHER.

• Turns the turret drive and turret power switches to OFF.

7. **Driver:** Turns the master power to OFF.

8. **BC or Gunner:** Sitting on stowage bin, removes the four discharger caps and grenades from top to bottom.

a. Installs the discharger caps on the grenade launcher tubes.

b. Opens the bins to stow the grenades.

c. Stows the grenades metal end down.

d. Closes and latches the smoke grenade stowage bin.

Crew Drill 15
DESTROY OR ABANDON AN M2 BRADLEY
FIGHTING VEHICLE (CREW)

SITUATION: Given an order to destroy or abandon the BFV, 15 one-pound blocks of TNT (or equivalent), equipment to complete an electric or nonelectric firing circuit, or two incendiary grenades, and a vehicle crew and a firing team.

REQUIRED ACTIONS:

1. **Destruction by Removal or Destruction of Main Components.**

a. ***Bradley Commander:***

- Removes the 7.62-mm coaxial machine gun backplate and destroys it.
- Smashes the radios.
- Secures his protective mask, and individual weapon, gear, and the night vision goggles.

b. **Gunner:**

- Takes the bolt assembly from the 25-mm automatic gun.
- Smashes the ISU.
- Secures his protective mask, and individual weapon and gear; and evacuates the vehicle.

c. ***Driver:***

- Cuts the coolant lines.
- Cuts the engine oil hose.
- Smashes the AN/VVS-2 night vision viewer.
- Secures his protective mask, individual weapon and gear.

d. **Team Members:**

- Secures all night vision devices.
- Secures dismounted radio.
- Secures their protective mask, and individual weapons and gear; and evacuates the vehicle.

2. **Destruction by Fire.**

a. ***Bradley Commander:***

- Traverses the turret to 4100 mils.
- Secures his protective mask and individual weapon.

b. **Driver:**

- Discharges the Halon bottle in the engine compartment.
- Lowers the ramp; opens the power unit access door.
- Opens the main fuel manual shutoff valve and main fuel drain valve, and cuts the fuel lines,
- Secures his weapon and protective mask, and evacuates the vehicle.

c. **Fire Team Members:**

- Open the cargo hatch.
- Secure the weapon and protective mask, and evacuates the vehicle.
- Discharge the Halon bottle; removes and empties the portable fire extinguishers.

d. **Bradley Commander:**

- Secures two incendiary grenades.
- Places one grenade in the power unit and one in the crew compartment, and evacuates the vehicle.

DANGER
TEAM MEMBERS MUST TAKE COVER WITHOUT DELAY,
BECAUSE THE FIRE MAY CAUSE AN EARLY EXPLOSION
OF AMMUNITION.

3. **Destruction by Antiarmor Fire.** The BC—

- Has the team members dismount with protective masks, individual weapons, and light antitank weapons (AT4s).
- Has the antiarmor specialist secure the Dragon or AT4.
- Moves the team past the minimum range of the Dragon (65 meters) and within maximum range of the AT4 (300 meters).
- Directs a volley of fire, aiming at the armament, engine, and drive train components.

DANGER
DO NOT FIRE AT EQUIPMENT UNTIL ALL SOLDIERS IN
THE AREA ARE A SAFE DISTANCE AWAY.

4. **Destruction by Demolition.**a. **Gunner:**

- Prepares three 1-pound blocks of TNT or the equivalent.

- Places the charges as follows:
 - On the receiver of the 7.62-mm coax.
 - On the receiver of the 25-mm.
 - On the integrated sight unit.
- b. **Driver:**
 - Prepares six 2-pound charges using 1-pound blocks of TNT or the equivalent.
 - Places the charges as follows:
 - One charge on the accessory end of the engine.
 - The second and third charges on the engine - one on the left side and the other on the right side.
 - The fourth charge between the engine and the cross drive transmission.
 - The fifth and sixth charges on the left and right track drive sprockets.
- c. **Bradley Commander:**
 - Provides for dual priming to minimize the possibility of a misfire.
 - Connects all charges (the charges for the turret and engine compartment) for simultaneous detonation.
 - Moves team members (with protective masks and individual weapons) to a covered area.
 - Detonates the charge.

NOTE: Ammunition and equipment that are not destroyed by the detonation should be removed from the vehicle and destroyed by other methods.

5. **Destruction by Using Natural Surroundings.** The team members:
 - Remove the major components (backplate from the 7.62-mm coax, the bolt from the 25-mm main gun) and submerge them in water (lakes, ponds, rivers, and so forth). If possible, submerge the vehicle.
 - If no body of water is near, widely disperse components (backplate from the 7.62-mm coax, the bolt from the 25-mm main gun), preferably into heavy underbrush.
 - Break down the bolt and track assembly before disposing of the parts. The BC or gunner keeps the firing pin assembly.

Crew Drill 16
PERFORM BEFORE-, DURING-, AND
AFTER-COMBAT-OPERATION CHECKS (CREW)

SITUATION: During assembly area procedures, after an engagement, or during consolidation and reorganization.

REQUIRED ACTIONS:

1. Before-Combat-Operation Checks.

NOTE: Follow all safety procedures while working in and around the turret, and ensure that no weapons are loaded with ammunition when performing the before-operation checklist.

a. **Squad Leader** (personally or through coordination with the team leaders)—

- Checks to ensure that all personnel are properly wearing personal protective equipment IAW the unit SOP and commander's guidance (for example, protective mask, protective body armor, helmet, nerve-agent antidote). Ensures that all personnel have hearing protection.
- Ensures that all personnel have their assigned weapons and the prescribed ammunition load.
- Checks to ensure that all weapons are loaded and placed on SAFE (to include firing port weapons).
- Ensures that ammunition and pyrotechnics are properly stowed (for example, grenades, flares, small arms ammunition, smoke, LAWs, Claymores, hand grenades).
- Ensures that all target acquisition devices (for example, NOD, binoculars, AN/PVS-5/7, AN/TAS-5) are properly stowed.
- Ensures that the hand grenades are worn properly.
- Ensures that all dismount equipment is functional (for example, test fires the weapons, conducts a communications check with the AN/PRC-77/68).
- For night operations, ensures that all NVD and other target acquisition equipment (for example, binoculars, AN/PVS-5/6) are mounted and available, and operational and zeroed to the appropriate weapon for night operations.

- Ensures that all personnel have additional equipment required to accomplish the mission IAW with METT-T (for example, minefield marking set, wire cutters, obstacle breach kit).
- Reports the status of the squad to the platoon sergeant.
- Ensures all personnel and vehicles are camouflaged.

b. **Gunner or Bradley Commander.** Ensures the following before-combat-operation checks are performed:

- Ensures that the weapons systems are on SAFE (electrical and manual).
- Ensures that all vehicle weapons systems are properly installed, and the prescribed ammunition is uploaded and stowed IAW the stowage and strapping diagram, vehicle load plan, and platoon SOP.
- Ensures all turret weapons systems are operational and boresighted. Conducts a prefire checklist in accordance with the standards outlined in FM 23-1.
- Ensures the vehicle communications systems are operational.
- Ensures that the turret PMCS has been conducted IAW TM 9-2350-252-10-2 or TM 9-2350-284-10-2.
- Checks individual equipment and weapons of the driver and gunner.
- Reports the status of the vehicle to the BC or section leader.

NOTE: During training, in the event the override system is inoperable and the turret interlock system malfunction, the turret drive system should not be used, until it is repaired or fully operational.

c. **Driver:**

- Conducts before-operation-hull PMCS in accordance with TM 9-2350-252-10-1 and TM 9-2350-284-10-1.
- Reports the status of the vehicle to the BC.

d. **Platoon Sergeant:**

- Consolidates the reports from the squad leaders and BCs, and reports the platoon's status to the platoon leader.
- Checks the aidman for complete aid bag.
- Checks the FIST for individual weapons and equipment; operational mission equipment (for example, laser range finder); operational communications (for example, digital message device and radios); any other mission-essential equipment.
- Other attachments as required.

e. **Platoon Leader:**

- Checks the special equipment required to execute the mission, and designates where it will be carried.
- Reports the platoon status to the company commander NLT the mission start time.

2. **During-Combat-Operation Checks.** During-combat-operation checks should be conducted in a secure location during a lull in the battle.

a. **Squad Leader or Team Leader:**

- Ensures the accountability of all soldiers and equipment.
- Supervises aid to injured soldiers.
- Ensures the weapons are on SAFE.
- Checks ammunition status, gets more ammunition from vehicle if possible, cross levels when necessary, and reports the critical shortages to the platoon sergeant.
- Reports the status of personnel, equipment, and ammunition to the platoon sergeant.
- Ensures dismounted security is established.

b. **Bradley Commander or Gunner:**

- Places the turret system on electrical SAFE.
- Checks ammunition status for all turret weapon systems, performs reload drills when required, cross levels from other BFVs when necessary, and reports the critical shortages to the section leader or platoon sergeant.
- Verifies the boresight of all weapons systems.
- Checks for damaged equipment.
- Ensures communications (radios and intercommunications) are operable.
- Conducts a visual inspection of the turret.
- Ensures the commander's and gunner's handstations are operable.
- Performs during-operation-turret PMCS in accordance with TM 9-2350-252-10-2 or TM 9-2350-284-10-2.
- Reports the status of the vehicle to the section leader or BC.
- Supervises expedient vehicle repairs, if necessary.

c. **Driver:**

- Performs during-operation-hull PMCS in accordance with TM 9-2350-252-10-1 or TM 9-2350-284-10-1.

- Conducts a visual inspection of the exterior of the vehicle.
- Checks all bolts and nuts on the road wheels and idle wheels.
- Checks fuel status and oil levels in the engine, transmission, fan tower, final drive ramp motor, road wheels, return roller hub windows, and idler wheels.
- Checks the engine compartment for any visible signs of damage.
- Reports the status to the BC.

d. **Platoon Sergeant:**

- Reports the status of the platoon to the platoon leader.
- Supervises the evacuation of casualties.
- Reports the location and status of inoperative vehicles and the WIA or KIA to the platoon leader.
- Coordinates for resupply, if required (for example, POL, ammunition).

e. **Platoon Leader:**

- Reports the status of the platoon to the company commander (if resupply or repairs are necessary to complete the mission, if required by SOP, or if the platoon has suffered combat or maintenance vehicle losses).

3. After-Combat-Operation Checks. After-combat-operation checks are to be forwarded in conjunction with consolidation and reorganization, and the infantry is normally dismounted and provides the local security while the BFV crew perform the necessary checks.

a. **Squad Leader or Team Leader:**

- Ensures that dismounted security is established.
- Checks for injured soldiers.
- Accounts for all personnel and equipment.
- Checks and ensures that all weapons are on SAFE.
- Reestablishes the chain of command.
- Checks the status of ammunition and supplies.
- Ensures that hasty positions are prepared, ensures that the key weapons are manned, and replaces vehicle crew members, as needed.
- Ensures that soldiers and vehicles are recamouflaged as necessary.
- Reports the status of soldiers, equipment, and ammunition to the platoon sergeant.

b. Bradley Commander or Gunner:

- Places turret system on electrical SAFE.
- Ensures that ammunition resupply is conducted for all weapons on the vehicle.
- Conducts a visual inspection of the turret for damages.
- Checks communications (radios and intercommunications) for damage.
- Performs after-operation-turret PMCS IAW TM 9-2350-252-10-2 or TM 9-2350-284-10-2.
- Confirms zero with a few rounds.
- Reports the status of the vehicle to the section leader or BC.

c. Driver:

- Conducts a visual inspection of the vehicle exterior.
- Performs after-operation-hull PMCS IAW TM 9-2350-252-10-1 or TM 9-2350-284-10-1.
- Checks all bolts and nuts on the road wheels and idle wheels.
- Checks fuel status and oil levels in the engine, transmission, fan tower, final drives, ramp motor and return roller hub windows, road wheels, and idler wheels.
- Checks the engine compartment for any visible signs of damage.
- Reports the status to the BC.

d. Platoon Sergeant:

- Reports vehicle, soldiers, equipment, and ammunition status to the platoon leader and company executive officer or first sergeant IAW the unit SOP.
- Supervises evacuation of wounded soldiers, inoperative equipment, and vehicle.
- Requests replacements and resupply (personnel, equipment, batteries, POL, ammunition) from the first sergeant IAW the unit SOP.
- Supervises the repair of equipment and vehicles within the capability.

e. Platoon Leader:

- Determines and disseminates the lessons learned with the platoon sergeant and squad leaders.
- Reports the platoon status to the company commander.

CHAPTER 4

MECHANIZED INFANTRY PLATOON TACTICAL STANDING OPERATING PROCEDURES

This chapter provides the tactical standing operating procedures for mechanized infantry platoons and squads. The procedures apply unless a leader makes a decision to deviate from them based on the factors of METT-T. In such a case, the exception applies only to the particular situation for which the leader made the decision.

This mechanized infantry platoon tactical SOP will help to maintain and improve the combat readiness of the platoon. To be effective, it should be reviewed and updated with doctrinal changes. This tactical SOP is not a substitute for good tactical training but rather an aid in preparing the platoon for future battlefields.

CONTENTS

ANNEX A. TASK ORGANIZATION

ANNEX B. COMMAND AND CONTROL

Appendix 1. Communications

Appendix 2. Estimate of the Situation

Appendix 3. Orders and Reports

Appendix 4. Movement

ANNEX C. OPERATIONS

Appendix 1. Assembly Area Procedures

Appendix 2. Smoke Producers

Appendix 3. Load Plans

ANNEX D. NBC

ANNEX E. AIR DEFENSE

ANNEX F. FIRE SUPPORT

ANNEX G. FIRE CONTROL AND DISTRIBUTION

ANNEX H. OPERATIONAL SECURITY

ANNEX I. COMBAT SERVICE SUPPORT

ANNEX A (TASK ORGANIZATION) to MECHANIZED INFANTRY PLATOON TACTICAL SOP

1. TASK ORGANIZATION. The platoon is organized to fight with a mounted and a dismounted element according to METT-T. The company or team commander designates the BFV platoon as the main effort or a supporting effort for the unit's mission accomplishment.

2. ATTACHMENTS.

a. Engineers. Engineers normally have already been assigned a priority of work by the company commander. The platoon leader will not dictate the employment or further suballocate or task organize any supporting engineer elements. He coordinates with all engineers operating in his area to ensure the commander's priorities are being adhered to. He must also ensure that engineer assets are not wasted and he must also provide guides to and from his platoon area. The platoon leader may be required to provide personnel for labor and or security to assist the engineers.

b. Stinger Teams. Stinger teams are usually in direct support of the company during the defense and under OPCON during the offense. The platoon leader does not change the priority of air defense protection established by the commander. The Stinger leader positions the Stingers where they can best provide support. The BFV platoon will often need to provide security for the Stinger team.

c. GSR Teams. Often collocated with the BFV platoon. These elements are usually in direct support to the battalion. The platoon leader coordinates with these teams to ensure they understand the mission.

ANNEX B (COMMAND AND CONTROL) to MECHANIZED INFANTRY PLATOON TACTICAL SOP

1. COMMAND. Platoon leaders are responsible for effectively using the platoon's resources and for the employing, organizing, and directing the platoon during combat operations. Effective command allows subordinate leaders to exercise their initiative, take risks, and seize opportunities during the mission.

a. Succession of Command. During combat, any member of the platoon may be required to assume command. Under normal conditions, the platoon succession of command will be—

- (1) Platoon leader.
- (2) Platoon sergeant.
- (3) Next senior leader.

b. Assumption of Command. When a new leader assumes command of the platoon, if and when the situations allows it, he accomplishes the following tasks:

- (1) Inform higher headquarters of the change.
- (2) Reestablish the platoon chain of command and ensure all subordinates are informed of changes.
- (3) Check the platoon's security and the emplacement of key weapons.
- (4) Check the platoon's equipment and personnel status.
- (5) Pinpoint the platoon's location.
- (6) Assess the platoon's ability to continue the mission.
- (7) Inform higher command of assessment.
- (8) Continue the mission.

2. CONTROL. The challenge to the leader is to use the minimal amount of control required to synchronize the operation, while still allowing decentralized decision making.

3. COORDINATION. Adjacent unit coordination is accomplished from left to right and from front to rear. Adjacent unit coordination is done face to face when possible. The following information is exchanged by adjacent units:

- Unit identification.
- Mission.
- Unit locations.

- Frequencies and call signs.
- Security plans.
- Fire support plans.
- Obstacle plans.
- CP and OP locations.
- Challenge and passwords.
- Sector sketches and or scheme of maneuver.
- Routes.
- Pyrotechnic signals.
- Fire control measures.

APPENDIXES:

1. COMMUNICATION
2. ESTIMATE OF THE SITUATION
3. ORDERS AND REPORTS
4. MOVEMENT

APPENDIX 1 (COMMUNICATION)
to
ANNEX B (COMMAND AND CONTROL)
to
MECHANIZED INFANTRY PLATOON
TACTICAL SOP

1. GENERAL. The three primary means of communication available to the BFV platoon are radio, wire, and messenger. Normally, the platoon uses one or all of these during an operation. Additionally, the platoon leader plans an alternate means of communication in case the primary means fails.

a. Radio. Radio is the least secure means of communication. Radio is susceptible to interception and jamming. Proper radio procedures must be used to reduce the enemy's opportunity to hamper radio communications.

(1) ***Radio procedures:***

(a) Change frequencies and call signs IAW the SOI.

(b) Keep transmission as brief as possible.

(c) Use established formats to expedite transmissions such as SALUTE.

(d) Encode messages or use secure voice.

(e) Use brevity codes when possible.

(2) ***Actions if jamming is suspected:***

(a) *Continue to operate.* (Do not let the enemy know that he is having any affect on communications.)

(b) *Disconnect the antenna.* If interference stops, communications are probably being jammed.

(c) *Switch to highest power.*

(d) *Relocate the radio.* Terrain may mask the enemy's jamming signal.

(e) *Use a directional antenna.*

(f) *Turn the squelch off.*

(3) ***Radio nets:*** The platoon must monitor and operate on several radio nets. These include—

(a) *Company command net.* The platoon continuously monitors the company command net.

(b) *Platoon net.* The platoon headquarters controls the platoon net. The platoon net is continuously monitored by all elements of the platoon.

(c) *Fire support net.* The fire support net is controlled by the battalion FSO and is monitored by the platoon's FO.

b. **Wire.** Wire is more secure than radio and is effected less by weather and terrain. When possible, the platoon uses wire in lieu of radio. When the tactical situation permits, the platoon establishes a wire net or "hot loop." This is accomplished as follows:

(1) Each element is responsible for running wire to the platoon headquarters.

(2) Each element of the platoon is responsible for running wire to the element on its left.

(3) Each element is responsible for running wire to its OP

(4) Once established, each element is responsible for the maintenance of the wire it laid. Additionally, each element continuously monitors the wire net.

(5) When breaking down the wire net, each element is responsible for recovering its wire.

(6) The platoon headquarter maintains overall control of the wire net.

c. **Messenger.** Messenger is the most secure means of communications. Messengers should vary their routes and schedules. Platoon leaders weigh the risk associated with using messengers. Although secure, messengers are the slowest form of communication.

2. CODE WORDS AND SIGNALS.

a. **Code Words.** Code words are used for a multitude of reasons. Code words are established to speed up communications, add a degree of security, and help with command and control. Code words are usually established during tactical operations for objectives, phase lines, check points, link ups, and so forth.

b. **Signals.** Signals can be used in many forms on any operation. Signals are usually either audio or visual. The key to the use of signals is ensuring *everyone* is aware of the signal and its meaning. (See FM 21-60.)

**APPENDIX 2 (ESTIMATE OF THE SITUATION)
to
ANNEX B (COMMAND AND CONTROL)
to
MECHANIZED INFANTRY PLATOON
TACTICAL SOP**

1. MISSION ANALYSIS.

- a. Mission and intent of commander two levels up.
- b. Mission and intent of immediate commander.
- c. Assigned tasks (specified and implied).
- d. Constraints and limitations.
- e. Mission-essential tasks.
- f. Restated mission.
- g. Tentative time schedule.

2. ESTIMATE OF THE SITUATION AND DETERMINATION OF COURSES OF ACTION.

a. Terrain and weather.

- (1) Terrain - OAKOC.
- (2) Weather - visibility, mobility, survivability.

b. Enemy situation and most probable courses of action.

- (1) Composition.
- (2) Disposition.
- (3) Recent activities.
- (4) Capabilities.
- (5) Weaknesses.
- (6) Most probable course of action (enemy use of METT-T).

c. Friendly Situation.

- (1) Troops available.
- (2) Equipment status.
- (3) Time available.

d. Friendly Courses of Action. (Develop at a minimum two courses of action.)

3. ANALYSIS OF COURSES OF ACTION.

- a. Significant factors.
- b. Wargame.

4. COMPARISON OF COURSES OF ACTION.

5. DECISION.

**APPENDIX 3 (ORDERS AND REPORTS)
to
ANNEX B (COMMAND AND CONTROL)
to
MECHANIZED INFANTRY PLATOON
TACTICAL SOP**

1. ORDERS.

a. Orders Group.

(1) **Company orders.** As a minimum, the platoon leader, platoon FO, and attachments leaders attend company orders.

(2) **Platoon orders.** As a minimum, the following individuals attend platoon orders:

- Platoon leader.
- Platoon sergeant.
- Squad leaders.
- Platoon FO.
- Aidman.
- Attachment leaders.

b. Orders Formats.

(1) **Warning order.** A warning order has no specific format. One technique is to use the five-paragraph operation order format. The leader issues the warning order with all the information he has available at the time.

(2) **Operation order.** The operation order is normally issued orally. The leader uses notes that follow the five-paragraph format.

(3) **Fragmentary order.** The format for a FRAGO is that portion of the current OPORD that has changed. If significant changes have occurred since the last OPORD, a new OPORD should be prepared.

2. REPORTS. Although each report has a prescribed format to ensure the completeness of the information reported, platoon leaders are reminded that in fast-moving tactical situations timely reporting especially of enemy activity is critical. Reports are not delayed in order to ensure correct format. REPORT ACCURATE INFORMATION IN A TIMELY MANNER. All color codes use the following criteria:

GREEN: 80 percent or better on hand—full strength

AMBER: 60 percent on hand—mission capable

RED: 40 percent to 59 percent on hand—marginally mission capable

BLACK: 39 percent or less on hand—not mission capable

OPERATIONS (BLUE REPORTS)

BLUE 1: Spot Report

BLUE 2: Situation Report

BLUE 11: Stand-to Report

INTELLIGENCE (GREEN REPORTS)

GREEN 2 Sensitive Items Report

GREEN 5: Meaconing, Intrusion, Jamming, and Interference (MIJI) Report

LOGISTICS (YELLOW REPORTS)

YELLOW 1: Equipment Status Report

YELLOW 2: Ammo Status Report

YELLOW 3: POL Status Report

PERSONNEL (RED REPORTS)

RED 2: Personnel Battle Loss Report

RED 3: Medical Evacuation Request

NBC REPORTS

NBC-1: Observer's Initial Report

NBC-4: Report of Radiation Dose-Rate Measurement

BLUE 1. SPOT REPORT (SPOTREP)

1. When Used. Used by all units when observing any known or suspected enemy activity. When observing any characteristic of the area of operations likely to effect accomplishment of the mission. Submitted through both operations and intelligence channels. SPOTREPs take priority over all other routine radio traffic. SPOTREP is submitted as a minimum, upon—

First enemy contact.

A break in contact.

Contact with a new enemy unit or equipment.

Significant change in tactical situation.

Unusual or unexplained activity.

Enemy reconnaissance activity.

Any level I, II, or III rear activity.

Indications of enemy NBC activity.

Significant enemy ADA, aviation, or engineer activity.

Indications that the enemy is changing its present course of action.

Other enemy and friendly activity as deemed significant.

2. Format.**SPOTREP**

Line 1: Who is observer or source:

(Omit if calling station; use call signs or description otherwise.)

Line 2: What is observed: size, activity, location, unit, time, and equipment (S-A-L-U-T-E).

Size:

(The number of sighted personnel and/or vehicles.)

Activity:

(What the enemy is doing.)

Location:

(Grid or reference from a known point.)

Unit:

(Patches, signs, or markings.)

Time:

(The time the activity was observed.)

Equipment:

(Describe or identify all equipment associated with the activity.)

Line 3: What are or were your actions or what do you recommend:

BLUE 2. SITUATION REPORT (SITREP)

1. Purpose. The SITREP is submitted to the company commander to report changes in the platoon's tactical situation and status. SITREPs are submitted after or during significant events, when combat capability changes, or as otherwise requested by the platoon leader.

2. Format.

SITREP

Line 1: Report as of date-time group.

Line 2: Brief summary of enemy activity, casualties inflicted prisoners captured.

Line 3: Friendly location encoded:

- a. CP locations.
- b. First subelement center of mass.
- c. Second subelement center of mass.
- d. Third subelement center of mass.

Line 4: Combat vehicles operational.

Line 5: Defensive Obstacles.

- a. Coordinates of minefield.
- b. Coordinates of demolitions executed.

Line 6: Personnel strength.

GREEN: 80 percent or better on hand—full strength

AMBER: 60 percent on hand—mission capable

RED: 40 percent to 59 percent on hand—marginally mission capable

BLACK: 39 percent or less on hand—not mission capable

Line 7: Class III and V for combat vehicles.

- a. Ammunition—Green, Amber, Red, or Black.
- b. Fuel—Green, Amber, Red, or Black.

BLUE 11 - STAND-TO REPORT

1. When used. A report is sent to the commander when stand-to is completed.

2. Format.

ALFA: Stand-to completed.

BRAVO: Weapons present/functional.

CHARLIE: SOIs/sensitive items present.

DELTA Inoperative vehicles or radios.

GREEN 2. SENSITIVE ITEMS REPORT (SENSREP)

1. Purpose. The Sensitive Item Report is used to report the results of a serial number check of all sensitive items.

2. Format.

SENSREP

Line 1. Reporting unit:
(Use call sign.)

Line 2: Results of check: (Normally "AU Present." Report line description, serial number, and explanation for missing items.)

- a. Machine guns:
- b. Submachine guns:
- c. M249s:
- d. Rifles:
- e. Pistols:
- f. Night vision devices:
- g. Binoculars:
- h. Radiacmeters:
- i. Dosimeters:
- j. SOI extracts:
- k. Special equipment:
(Assigned to platoon for particular operations,
Example: crew-served NVD, mine detectors.)

Line 3: Preparer:
(Initials of individual responsible for preparing the report.)

Line 4: Transmission time:
(Date-time group of transmission. Use only if directed.)

GREEN 5. MEACONING, INTRUSION, JAMMING, AND INTERFERENCE REPORT (MIJI REPORT)

1. Purpose. MIJI reports are submitted when—

a. The reception of radio signals is hindered, prevented, confused or distorted by any type of signal received from an external source (disconnect antenna to check).

b. Imitative deception is suspected (that is, instructions are received from a station which cannot authenticate).

NOTE: MIJI reports must be submitted to the S2 and signal officer without delay.

2. Format.

MIJIREP

Line 1: Unit:

(Unit identification.)

Line 2: Type:

(Type of interference.)

Line 3: Location:

(Best grid or reference to known point.)

Line 4: On time:

(Start date-time group.)

Line 5: Off time:

(Off date-time group.)

Line 6: Effects:

Operations/equipment affected.)

Line 7: Frequency:

(Frequency/frequency range.)

Line 8: Narrative:

(Date-time group of transmission. Use only if directed.)

Line 10: Authorization:

(Message authorized according to current guidelines.
Use only if directed.)

YELLOW 1. EQUIPMENT STATUS REPORT

1. When Used. A Yellow 1 Report will be sent by messenger or FM radio, to the PSG between 1200 hours and 1300 hours daily. The information will be as of 1200 hours that same day.

2. Format. The following line numbers will be categorized as:

- a. operational
- b. inoperative
- c. combat loss

LINE NUMBER NOMENCLATURE/MODEL

Weapons

- 1 Bayonet knife, with scabbard for M16A1/2 rifle
- 2 Pistol, cal .45 automatic/9-mm
- 3 Rifle, 5.56-mm, with equipment
- 4 Launcher, Grenade, 40-mm single shot rifle mounted, detachable with equipment
- 5 Squad Automatic Weapon, M249, spare barrel
- 6 Squad Automatic Weapon, M249
- 10 Machine gun, 7.62-mm, fried M240C **RH** feed **F/FVS**
- 11 Launcher, grenade, smoke screening
RP M257
Gun, 25-mm, M242 (turret type)

Vehicles and Vehicle Equipment

- 15 **CFV, M3**
- 16 Carrier, 107-mortar, self-propelled (less mortar), M106
- 17 Carrier, personnel, full-tracked armored, M1 13
- 18 Carrier, 81-mm mortar, full-tracked (less mortar)
- 19 Truck, utility, 1/4-ton 4x4 WE, M151
- 20 Tank, M60A3
- 21 Tank, M1

LINE NUMBER NOMENCLATURE/MODEL**NBC Equipment**

- 22 Alarm, chemical agent auto, portable (ptbl), F/Full trkd armored personnel carrier (APC) and armored recovery vehicle (ARV)
- 23 Alarm, chemical agent auto, ptbl w/pwr supply, **F/trk** util, 1/4-ton
- 24 Charger, radiac detector, PPP-4370/PD
- 25 Mask, chemical-biological, multipurpose
- 26 Radiacmeter, IM-185/UD
- 27 Alarm, chemical-agent auto, ptbl, manpack
- 28 Radiacmeter, IM-93/UD
- 29 Radiacmeter, IM-174-PD
- 30 Radiacmeter, AN/VDR-1

Radios

- 31 Radio Set, AN/GRC-106
- 32 Radio Set, AN/GRC-160
- 33 Radio Set, AN/VRC-46
- 34 Radio Set, AN/VRC-47
- 35 Radio Set, An/VRC-64
- 36 Radio Set, AN/PRC-77
- 37 Radio Set, AN/VRC-12
- 38 Demolition set, explosive, initiating nonelectric
- 39 Detecting set, mine, ptbl, metallic and nonmetallic
- 40 Detecting set, mine, ptbl, metallic (AN/PSS-11)
- 41 Night-vision goggles, AN/PVS-5
- 42 Night vision sight crew-served weapon, AN/TVS-5
- 43 Night-vision sight individual-served weapon, AN/PVS-4
- 44 PEWS, AN/TRS-2(V)
- 45 Binoculars, modular construction, military scale reticle 7x50-mm WE

LINE NUMBER NOMENCLATURE/MODEL***Radios (continued)***

46	Telescope, straight, military
47	Detector, radar signal, AN/PSS-10
48	Position locating reporting system basic user unit
49	Position locating reporting system surface vehicle installation kit

3. Example:

“THIS IS RED 3. YELLOW 1. LINE 14: ALFA. LINE 27: ALFA 1, BRAVO 1 LINE 38: CHARLIE. LINE 47: CHARLIE, OVER.”

YELLOW 2. AMMO STATUS REPORT

1. **When Used.** Yellow 2 reports will be transmitted once daily at 1300 hours, or immediately upon completion of enemy contact.

CODE: CRITERIA

GREEN 80 percent or better on hand, all types of ammo

AMBER 60 to 79 percent on hand, all ammo

RED 40 to 59 percent on hand, all ammo

*BLACK 39 percent or less on hand, all ammo

*Reporting Yellow 2 Black signals an immediate resupply is required.

2. **Format.** The following line number designators will be used:

REF NUMBER	NOMENCLATURE	QUANTITY REQUIRED
1	Report as of DTG	
2	105-mm, HEAT	
3	105-mm, HEP	
4	105-mm, APERS	
5	105-mm, WP	
6	105-mm, APDS	
7	105-mm, HEDP	
8	Cal .50 (M85)	
9	Cal .50 (M2)	
10.....	25-mm	
11	7.62-mm (COAX/M60)	
12.....	4.2-in HE w/fuze	
13.....	4.2-in WP w/fuze	
14.....	4.2-in ILLUM w/fuze	
15.....	81-mm, HE w/fuze	
16.....	81-mm, WP w/fuze	
17.....	81-mm, ILLUM w/fuze	
18.....	Fuze, prox (4.2-in)	
19.....	Fuze, PD (4.2-in)	
20.....	Fuze, prox (81-mm)	
21.....	Fuze, PD (81-mm)	

REF NUMBER	NOMENCLATURE	QUANTITY REQUIRED
22	Blasting cap, nonelec	
23	Fuze, igniter	
24	5.56-mm Ball	
25	5.56-mm Tracer	
26	Redeye, XM41E2	
27	Grenade, Fragmentation	
28	Grenade, Smoke	
29	Grenade, Thermite	
31	Grenade, 40-mm, HE	
32	Grenade, 40-mm, WP	
33	Grenade, 40-mm, AP	
34	45 Cal/9-mm Ball	
35	M72 LAW/AT4	
36	Dragon	
37	TOW	
38	Stinger missile	
39	Mine, AT	
40	Mine, AP	
41	Mine, Claymore	
42	25-mm HE	
43	25-mm AP	
44	165-mm HE (CEV)	
45	(spare).....	
46	(spare).....	
47	(spare).....	
48	(spare).....	
49	(spare).....	
50	(spare).....	
51	(spare).....	

All quantities listed on Yellow 2 reports will be quantity required unless otherwise requested. This report is normally include.

3. Example:

“BLACK 3, THIS IS RED 4, YELLOW 2 BLACK LINE ONE: 091100 JUL 92. LINE 6: 40. LINE 11: 1600.”

NOTE: Use only lines affected. Attached units coordinate with S4 for additional line numbers for their peculiar type of weapons.

YELLOW 3. POL STATUS REPORT

1. When Used. This report is sent twice daily or as required.

2. Format.

CODE:	CRITERIA
GREEN	80 percent or better on hand
AMBER	60 to 79 percent on hand
RED	40 to 59 percent on hand
BLACK	39 percent or less on hand

The following line number designators will be used to indicate how much of a particular item is required:

REF NUMBER	NOMENCLATURE	U/L	QUANTITY REQUIRED
1	Report as of DTG	gal	
2	Mogas	gal	
3	Diesel	gal	
4	Oil, OE-10	gal	
5	Oil, OE-30	gal	
6	Oil, OE-5	gal	
7	Oil, OE-90	gal	
8	Antifreeze	gal	
9	Brake fluid	gal	
10	Hydraulic fluid OHA	qt	
11	Hydraulic fluid OHT	qt	
12	Hydraulic fluid FRH	qt	
13	Oil, penetrating	qt	
14	Oil, PL-Special	qt	
15	Oil, PL-Med	qt	
16	Bore cleaner	gal	
17	Oil, LSA	qt	
18	Grease, CAA	lb	
19	Grease, wheel bearing	lb	
20	Solvent	gal	

3. Example:

“BLACK 3, THIS IS RED 1. YELLOW 3, BREAK. LINE ONE:
112000 NOV 92. LINE THREE: 900. LINE 18: 15.”

RED 2. PERSONNEL BATTLE LOSS REPORT

1. When Used: A Red 2 report is transmitted to the platoon sergeant as casualty occurs. Platoon will also complete DA Form 1156 with witness statements DA Form 1155.

2. Format:

Line 1: Battle Roster number

Line 2: Date-time group of incident

Line 3: Location (encoded)

- a. KIA hostile action
- b. KIA nonhostile action
- c. Body recovered
- d. Body no identified
- e. Body identified
- f. MIA
- g. Captured
- h. WIA, slight, hostile
- i. WIA, serious, hostile
- j. WIA, slight, nonhostile
- k. WIA, serious, nonhostile
- l. Accident

Line 5: Evacuated to

RED 3 - MEDICAL EVACUATION REQUEST

1. When Used. A Red 3 (Medical Evacuation) is requested from the medical team on the company command net.

2. Format:

a. Use Air Evacuation Format as in SOI or use ground evacuation format.

b. Ground Evacuation:

Line 1: Evac

Line 2: Location for pickup (encode)

Line 3: Number of Casualties

Line 4: Category of patient

- a: Urgent
- b: Priority
- c: Routine

NOTE: Use letter with a number of patients; for example, a "2" indicates 2 patients for evacuation.

NBC-1. OBSERVER'S INITIAL REPORT

1. Purpose. NBC-1 Report is used when a chemical agent is first detected.

2. Format.

Line 1: Type of attack (nuclear, biological, or chemical):

Line 2: Location of observer:
(coordinates or place)

Line 3: Direction measured clockwise from grid north, true north, or magnetic north (state which) of the attack from observer:
(Degrees or mils, state which.)

Line 4: Date-time of detonation or date-time attack started:

Line 5: Illumination time in seconds for nuclear detonation:

Line 6: Linear target grids or location of attack or location of area attacked:
(Coordinates of place. Actual or estimated, state which.)

Line 7: Means of delivery or kind of attack:
(Guns, mortars, multiple rockets, missiles, bombs, spray—state which.)

Line 8: Type of burst (air, surface of unknown—state which) including height or type of agent, height of burst:

Line 9: Number of munitions or aircraft (state which):

Line 10: Flash to bang time (seconds):

Line 11: Crater present or absent and diameter (meters) or description of terrain/vegetation:

Line 12: Nuclear burst angular cloud width measured at H+5 minutes:
(Degrees or mils, state which.)

Line 13: stabilized cloud-top angle and/or cloud-bottom angle (state which) or cloud-top height and/or cloud-bottom height (state which) measured at H+10 minutes:
(Degrees, mils, meters, or feet—state which.)

Line 14: Date-time reading or date-time contamination detected:

Line 15: 20 cGy/hr (rad/hr) contour line coordinates (Black) or area of actual contamination (Yellow):

NBC-4. REPORT OF DOSE-RATE MEASUREMENT

NBC-4 NUCLEAR		
	Precedence Date/time (local or ZULU time, state which) Security Classification From To Type of Report	
LETTER	MEANING	EXAMPLE
O	Location of reading (UTM)	O. LB123967
R	Dose rate (rad/hr. The words "initial," "increasing," "peak," or "decreasing" may be added.	R. 35 INITIAL
S	Date/time of reading (local or ZULU, state which)	S. 201750 (local) O. LB 129965 R. 60 S. 201650 (local) O. LB146806 R. 27 INCREASING S. 201710 (local)
NBC-4 (CHEMICAL)		
H	Type of Agent	Nerve
O	Location of sampling/type	FS135642 AIR
S	Date/time of detection	170810Z

APPENDIX 4 (MOVEMENT)
to
ANNEX B (COMMAND AND CONTROL)
to
MECHANIZED INFANTRY PLATOON
TACTICAL SOP

1. MOVEMENT.

a. **Formations.** Leaders choose the formation based on their analysis of METT-T and likelihood of enemy contact.

(1) ***Dismounted Element Formations.***

(a) *Fire team formations.* All soldiers in the team must be able to see their leader.

1. *Wedge.* Used unless modified because of terrain, dense vegetation, terrain or mission; basic fire team formation.

2. *File.* Used in close terrain, dense vegetation, limited visibility.

(b) *Squad formations.* Squad formations describe the relationships between fire teams in the squad.

1. *Column.* Used unless METT-T dictates otherwise; primary squad formation.

2. *Line.* Used when maximum firepower is needed to the front

3. *File.* Used in close terrain, dense vegetation, or limited visibility.

(c) *Platoon formations.* METT-T determines where crew-served weapons move in the formation. They normally move with the platoon leader so he can quickly establish a base of fire.

1. *Column.* Used unless METT-T dictates otherwise; primary platoon formation.

2. *Platoon line, squads on line.* Used when the platoon leader wants all soldiers on line for maximum firepower forward. Used when the enemy situation is known.

3. *Platoon line, squads in column.* Used when the platoon leader does not want everyone forward, but wants to be prepared for contact such as near the objective.

4. *Platoon Vee.* Used when enemy situation is vague, but contact is expected to the front.

5. *Platoon wedge.* Used when enemy situation is vague and contact is not expected.

6. *Platoon file.* Used when visibility is poor due to terrain or light.

(2) **Mounted Formations.**

(a) **Column.** Used for road marches, movement during limited visibility conditions, and when passing through defiles or other restrictive terrain.

(b) **Line.** Used when assaulting a weakly defended objective, crossing open areas, or in a support by fire position.

(c) **Echelon.** Used to permit excellent firepower to the front and to either the right or left flank.

(d) **Wedge.** Used to permit excellent firepower to the front and good fires to each flank.

(e) **Herringbone.** Used to disperse the platoon when traveling in column formation.

(f) **Coil.** Used to provide all-round security and observation when the platoon is stationary.

b. **Movement Techniques.** Leaders choose a movement technique based on their mission analysis of METT-T and likelihood of enemy contact.

(1) **Traveling.** Used when contact is not likely and speed is important.

(2) **Traveling overwatch.** Used when contact is possible but speed is important.

(3) **Bounding overwatch.** Used when contact is likely or imminent and speed is not important.

2. TACTICAL ROAD MARCHES. Tactical marches are normally used to move platoons from rear areas to assembly areas in preparation for the mission. Although a company may be required to conduct a tactical march, the platoon and company normally move as part of the battalion. The tactical march is conducted when speed is essential, platoon integrity must be maintained, road nets are available, and chance of enemy contact is limited.

a. **Definitions.** The following definitions apply to tactical road marches and foot marches.

(1) **Arrival Time.** The time the head of a column reaches a designated point or line.

(2) **Clearance Time.** The time the tail of a column passes a designated point or line.

(3) **Column (Time) Gap.** The space between two consecutive elements calculated in units of length (meters) or units of time (minutes), measured from the rear of one element to the front of the following element.

(4) **Completion Time.** The time the tail of a column passes the release point.

(5) **Critical Point.** A point along the route of march used for reference in giving instructions; any point along the route where interference with the troop movement may occur.

(6) **March Unit.** A unit that moves and halts at the command of a single commander-platoon or company.

(7) **Pace Setter (Vehicle).** A vehicle in the lead element that is responsible for regulating speed.

(8) **Pass Time.** The time between the movement of the first element past a given point and the movement of the last element past the same point.

(9) **Rate of March.** The average kilometers-per-hour traveled.

(10) **Release Point.** A well-defined point on a route where the elements composing a column return to the direct control of their respective commanders.

(11) **Serial.** A grouping of march units under a single commander. It is usually a battalion, brigade, or larger unit. For convenience in planning, scheduling, and control, it is given a numerical or alphabetical designation.

(12) **Start Point.** A well-defined point on a route where all elements come under the control of the movement commander. It is at this point that the column is formed by the successive passing of each of the elements in the column.

(13) **Vehicle Distance.** The space between two consecutive vehicles of an element in the column. (Tail of one to front of the other.)

(14) **Organization of a March Column.** Depending on the size and number of units conducting the move, the battalion is normally formed as a serial with companies and elements of headquarters and headquarters company formed into march units. The entire column is organized into an advance party, main body, and trail party. The advance party consists of a reconnaissance element and a quartering party the trail party is made up of maintenance, recovery, and medical elements; and the main body is made up of the rest of the force.

(15) **Vehicle Dispersion.** The move can be conducted with vehicles in close column, open column, or by infiltration. The method is determined by the degree of control required and the terrain—for example, open terrain requires more dispersion than close terrain.

b. Column Spacing. In close column, vehicles are spaced about 25 meters apart during daylight. At night and during other reduced visibility, vehicles are spaced so that the driver and BC can see the two lights in the blackout marker of the vehicle ahead, if not the vehicle itself. Close column takes maximum advantage of traffic capacity of routes but provides little dispersion. Close column is normally used for marches

during darkness and blackout conditions and for moving rapidly through urban areas to ensure integrity and control of the column.

(1) In open columns, the distance between vehicles is increased to provide greater dispersion. Vehicle distance varies from 50 to 100 meters. The increased distance provides greater protection against air and artillery fires, and ground attack by small enemy forces. It also allows the command vehicle and other vehicles not restricted by march orders to pass the column without disrupting its organization.

(2) When moving by infiltration, vehicles are dispatched individually, in small groups, at irregular intervals in a rate that will keep traffic density down and prevent undue massing of vehicles. Infiltration provides the best possible defense against enemy observation and attack. It is suited for tactical road marches when enough time and road space are available and when maximum security, deception, and dispersion are desired. Infiltration is difficult to control.

(3) When vehicles are farther apart than prescribed in open or closed column, they close up by traveling at a prescribed higher speed. This catch-up speed is normally fast enough to allow the column to close up over a long distance, thus reducing the accordion effect produced by rapid changes in speed. A fixed catch-up speed also provides an additional safety factor for the march.

c. Conduct of the Tactical Road March. The movement order issued by the company commander includes information on the enemy and friendly situations, destination, route, rate-of-march, catch-up speed, order of march, start point, location and time, vehicle distances, release points, critical points, combat service support, communications, and location of commander during the march. Many items of a movement order are SOP. The commander normally issues strip maps of the route with the order. A strip map is a sketch of the route of march and contains as a minimum a start point, a release point, and critical points and distances between them. Strip maps should be issued to each vehicle commander.

(1) Before starting, each march unit has a designated team to reconnoiter its route to the start point and determine the amount of time needed to reach it. The company also forms a quartering party element. It links up with the battalion quartering party before moving to the new assembly area. The company quartering party is normally headed by the executive officer or first sergeant and consists of representatives from platoons, company headquarters, and attached elements if necessary. The battalion and company quartering parties move to the new assembly

area before the main body moves. Quartering parties normally move by infiltration. Quartering party SOPs should include—

- Securing the new assembly area.
- Monitoring NBC conditions.
- Searching for indications of enemy activity.
- Looking for mines and booby traps.
- Selecting routes to platoon locations.
- Selecting initial vehicle positions.
- Selecting initial machine gun and Dragon positions.
- Meeting platoons at the company release point and guiding vehicles into position.

(2) Although some movement and lining up may be required before starting the move to the SP, ideally vehicles move from their positions directly into their proper place in the march unit. The march unit should proceed to the SP without stopping, arrive thereon time, and pass through the SP at the proper speed and interval between vehicles.

(3) During the move, the occupants of each BFV maintain a 360-degree observation around the vehicle. The driver observes forward, the BC observes to the right of the 25-mm gun, and the gunner observes to the left of the 25-mm gun. The gunner and BC observe their assigned sectors regardless of the orientation of the turret. Soldiers inside the vehicle observe through periscopes in the troop compartment.

(4) Within the platoon column, each vehicle is assigned a sector of fire for the move. (Figure 4-1.) Each vehicle orients its 25-mm gun so that it can rapidly fire on targets within its sector. The assignment of sectors of fire, coupled with the capability of firing from firing ports, provides the platoon with 360-degree security while on the move.

(5) During the move, the platoon must be prepared to take action if attacked by enemy air, artillery, or ground forces. Passive measures against enemy air include maintaining proper interval between vehicles, staggering vehicle positions within the column to avoid linear patterns, camouflaging vehicles, and maintaining air observation.

(6) If attacked by enemy air, vehicles in the column move off the axis of attack, either occupying covered and concealed positions or continuing to move, maintaining an evasive course. The platoon also engages the aircraft with all available weapons.

(7) If the column receives indirect fire during the move, the vehicles are buttoned up and they move rapidly out of the impact area.

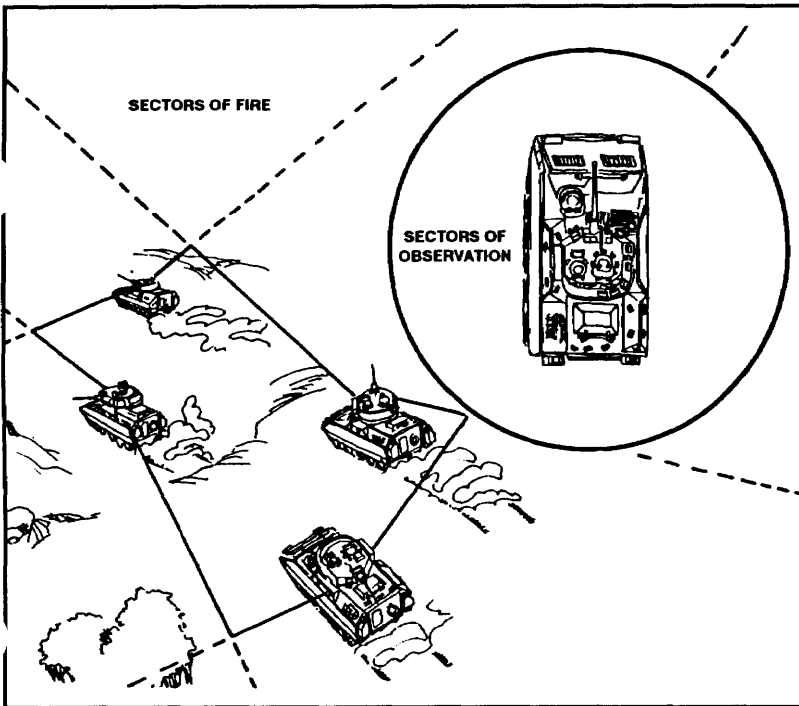

Figure 4-1. Sectors of observation and fire.

(8) If engaged by enemy ground forces while on a tactical road march, vehicles attempt to continue movement, or are directed by the platoon leader to assault or fix the enemy for other forces to attack.

(9) Because the primary mission of the unit is to move to a new location in preparation for future operations, additional actions against ground forces depend on the size of the enemy force and instructions from the company team/march unit commanders. If the enemy force consists of snipers or other disruptive forces equipped with small-arms weapons, the commander may pass through the force or dispatch a platoon to eliminate it. If the force is larger and presents a danger to the unit as a whole, fragmentary orders may be issued for march units to leave the route of march, move to covered and concealed positions, and conduct a hasty attack.

(10) A march unit can conduct three kinds of halts: scheduled, unscheduled, and vehicle breakdown.

(a) *Schedule halts* are planned for maintenance or rest, or to comply with higher level time schedules. At scheduled halts, vehicles pull to the side of the road but maintain vehicle distance. Fire teams dismount and establish local security.

(b) *Unscheduled halts* are caused by unforeseen developments (such as obstacles, ambushes, or other enemy activity forward of the platoon) that prohibits further movement. If off-road movement is possible, the company team forms a coil for hasty perimeter defense. Platoons occupy a sector of the coil using the clock system. If off-road movement is not possible, the company team forms a herringbone. Fire teams dismount to improve local security.

(c) When a *vehicle breakdown* occurs and the vehicle cannot continue the move, the BC ensures his vehicle is moved off the road so traffic is not slowed. If the vehicle blocks the road, it is towed or pushed away to clear the road. Once the vehicle is clear of the road, the crew attempts to repair the vehicle while the fire team establishes security, provides guides, and directs traffic. The platoon to which the disabled vehicle belongs normally continues to move. If the vehicle is repaired and the march unit has not passed completely, the vehicle rejoins the march unit at the tail end. If the march column has passed, or the vehicle cannot be repaired, the crew remains with the vehicle and waits for the serial's trail party. The trail party repairs the vehicle or tows it to the battalion trains in the battalion assembly area. If fighting strength is critical, the platoon crossroads the disabled vehicle's fire team.) .

NOTE: If the platoon leader's BFV is disabled, the platoon leader moves to another vehicle. The FO team should also be crossloaded.

(11) On arrival at the battalion release point, the leader of the company team's quartering party moves from a concealed position and guides the march unit to the company release point. Platoon guides direct the platoon's vehicles to their general locations, where the Bradley commander assumes control and selects vehicle positions if they have not been selected by the quartering party. Vehicles should not stop on roads or in open fields, but should move directly into concealed positions. Normally, the first platoon in the column is guided to positions farthest away from the entrance into the assembly area. Succeeding platoons should move as far as possible into the assembly area, with the last platoon closing and securing the entrance.

(12) If the company team must move into an unprepared assembly area, the clock system can be used to rapidly establish a perimeter defense

and road security. Normally, the direction of movement is 12 o'clock. The lead platoon usually takes up a third of the perimeter in the sector from 10 o'clock to 2 o'clock, with succeeding platoons breaking off left and right per company SOI.

(13) When movement into an assembly area is conducted at night, platoon guides must use easily recognizable visual signals to ensure the vehicles follow the proper guides. Use of different colored flashlight lenses, or chemical lights are methods of identifying platoon guides.

3. FOOT MARCHES. When moving along a road in a relatively secure area, the dismounted BFV platoon will move with one file on each side of the road. Fire teams are not split up. There will be 3 to 5 meters between soldiers and 25 to 50 meters between platoons.

a. The normal rate of march for an 8-hour march is 4 kmph. The interval and rate of march depend on the length of the march, time allowed, likelihood of enemy contact (ground, air, artillery), terrain and weather, condition of the soldiers, and the weight of the soldiers' load.

b. A 15-minute rest will be conducted at the end of the first 45 minutes of a road march. During this halt, the aidman and squad leaders will check the soldiers' feet and report the physical condition of the soldiers to the platoon leader and platoon sergeant. Thereafter, a 10-minute rest is conducted every 50 minutes.

4. ACTIONS AT HALTS. During halts, security is posted and all approaches into the unit's area are covered by key weapons. The platoon sergeant moves forward through the platoon, checking security as he goes, and meets the platoon leader to determine the reason for the halt.

a. During halts of 30 seconds or less, the soldiers drop to one knee and cover their assigned sector.

b. During halts longer than 30 seconds, a cigar-shaped perimeter is formed, and the soldiers assume the prone position.

5. ACTIONS ON CONTACT. On contact, the platoon executes the appropriate battle drill.

a. React to Contact.

b. Break Contact.

c. React to Ambush.

ANNEX C (OPERATIONS) to MECHANIZED INFANTRY PLATOON TACTICAL SOP

1. OFFENSE. BFV-equipped infantry platoons conduct offensive operations to close with and destroy the enemy and his will to fight. The platoon leader receives the mission from the company commander.

a. Preparation.

- (1) The platoon leader makes a quick mission analysis.
- (2) The platoon leader issues a warning order.
- (3) The platoon members concurrently prepare for combat. The chain of command conducts precombat inspections.
- (4) The platoon leader makes his tentative plan.
- (5) The platoon initiates movement as required.
- (6) The platoon conducts required reconnaissance to confirm or deny the tentative plan.
- (7) The platoon leader gives a briefback to the commander before issuing the order.
- (8) The platoon leader issues his order making sure that his subordinates have time to brief the soldiers and conduct rehearsals of key platoon actions. Certain rehearsals can take place before the OPORD (in the interest of time). First priority for rehearsals is actions on the objective.
- (9) The PSG requests CSS assets.
- (10) The platoon leader or representative coordinates with higher, supporting, and adjacent units and exchanges information on the following
 - Fire plans.
 - Scheme of maneuver.
 - Current intelligence.
 - Control measures.
 - Communications and signals.
 - Time schedules.
 - Support requirements.
- (11) The platoon leader supervises mission preparation, and plans for sustainment operations. Subordinate leaders conduct briefbacks of the plan to ensure his intent is understood.
- (12) Platoon continues to conduct reconnaissance during operation.

(13) The platoon leader monitors the actions of higher, adjacent, and supporting units.

(14) The platoon leader issues orders or modifies original plan as needed.

(15) The platoon headquarters reports combat critical information to higher, adjacent, and supporting units:

- SALUTE on enemy contact.
- Terrain information.
- Changes in platoon actions from the plan.
- Changes in the friendly situation (including attachments).
- Initiation of action by the platoon.
- CS or CSS requests required to execute tasks.
- Friendly information from other units that higher headquarters cannot monitor.

b. **Execution.** Offensive operations begin with a movement to contact, which usually results in a hasty or deliberate attack.

(1) **Hasty attack.** When the platoon makes contact with the enemy, it executes the contact drill.

- Deploy.
- Establish a base of fire.
- Find the enemy flank, gap, or weak point.
- Suppress the enemy.
- Attack through the flank, gap, or weak point.
- Report to the commander.

(2) **Deliberate attack.** A planned attack against the enemy.

(a) The platoon leader organizes the platoon for the attack, depending on the situation—assault element, support element, breach element.

(b) The platoon positions for the assault. The leaders reconnoiter the objective area and select a support-by-fire position. The platoon leader positions the BFVs to support the dismount element (unless the platoon is conducting a mounted assault).

The support element maintains continuous communications with the assault element and breach element. If possible, the support element maintains observation of the assault element and breach element and their routes. The support element ensures the assault element's and the

breach element's routes do not cross into the support positions' sectors of fire. The support element alerts the platoon leader of any movement on the objective or change in the enemy situation.

The platoon sergeant controls the support element which suppresses the objective with direct or indirect fires.

The platoon leader leads the dismounted assault element into the last covered and concealed position before the objective.

The platoon leader or FO requests fires on targets on the objective.

The breach element gets in position and breaches obstacles.

(c) The platoon performs the assault. The platoon leader signals to lift or shift the suppressive fires of the BFVs and indirect fires. (Primary signal is FM radio; alternate signal is visual.)

The breach element breaches the objective in an area of known weakness and suppresses enemy positions on the objective.

The assault element assaults the objective through the breach. The assault element suppresses and fights through the objective. The breach element reduces the obstacle.

On order, the support element moves onto the objective and assists with the destruction of remaining enemy forces.

(d) The platoon consolidates, then reorganizes. (Many events that occur during consolidation and reorganization will be concurrent.)

c. **Consolidation.** The BFV-equipped platoon occupies hasty defensive positions and prepares to repel an enemy counterattack.

(1) BFVs are moved into hull-down positions and assigned sectors of fire.

(2) Local security is established.

(3) Mutual support is established between mounted and dismounted elements, and adjacent platoons.

(4) Any remaining pockets of enemy resistance are eliminated.

(5) EPWs are secured.

(6) Dismounted fire teams prepare hasty firing positions.

d. **Reorganization.**

(1) The platoon leader reestablishes the chain of command and fills key positions:

- Replaces PSG or squad leaders who were casualties.
- Informs the company team commander of the platoon's status.

(2) The PSG and squad leaders—

- Replace key squad members who were lost (assistant squad leader, BFV gunner, driver).
- Replace gunners of Dragons and M249s.
- Reload coaxial machine gun and 25-mm gun ammunition ready boxes.
- Redistribute ammunition among dismounted rifle team members and get ammunition, as required, from the fighting vehicle.
- Move casualties to a covered position, get medical aid to them, and arrange for their evacuation (as required).
- Report to the platoon leader the situation, casualties incurred, and status of ammunition and missiles.

2. DEFENSE. BFV-equipped infantry platoons conduct defensive operations to retain terrain, gain time, and defeat attacking forces. The platoon leader receives the operations order from the company commander.

a. Preparation of the Defense.

(1) The platoon leader makes a quick mission analysis and issues a warning order to the platoon.

(2) Platoon members concurrently prepare for combat. The chain of command conducts precombat inspections.

(3) The platoon leader makes an estimate of the situation and a tentative plan.

(4) When possible, the platoon leader and selected individuals reconnoiter the defensive position and routes to it. They confirm or deny the tentative plan—vehicle positions and dismount element positions.

(5) The platoon leader completes the plan and issues the platoon operations order.

(6) The platoon sergeant plans and coordinates CSS.

(7) The platoon rehearses applicable drills and tasks.

(8) The platoon leader or his representative conducts adjacent unit coordination.

(9) The chain of command conducts the final inspection.

(10) When possible, a full-force rehearsal is conducted. If the platoon is designated as a reserve, it rehearses those actions as stated in the OPORD. As a minimum, briefback rehearsals are conducted with key leaders.

(11) The platoon begins movement to the platoon battle position. Vehicles are not moved directly forward from covered and concealed positions. The platoon moves on covered and concealed routes. Camouflage noise, and light discipline are enforced. All-round security is maintained.

(12) When an advanced party is not used, the platoon stops short of the battle position and establishes local security.

(13) The platoon leader, squad leaders (BFV commanders if possible) conduct reconnaissance. The reconnaissance party enters the position from the rear:

- Confirms and adjusts BFV and squad positions.
- Conducts reconnaissance forward of battle positions if possible.
- Checks for signs of enemy activity.

(14) The platoon occupies its initial battle position and start its priority of work:

(a) **Platoon Leader.**

- Establish local security. He may set up OPs, a hasty perimeter, or conduct security patrols.
- Conduct leader's reconnaissance with his squad leaders (BC if possible).
- Position BFVs, squads, Dragons, machine guns, and any attachments.
- Choose the CP location.
- Assign alternate and supplementary positions.
- Assign sectors of fire, engagement priorities, and other fire control measures.
- Develop an obstacle and fire plan.
- Develop a fire support plan (with the FO).
- Check the CP.
- Brief the platoon sergeant on logistics.
- Verify communications to higher and lower units.
- Make a sector sketch and send one copy to the commander IAW the platoon SOP.
- Confirm all positions (before digging starts) to include interlocking fires.
- Coordinate with left and right units.
- Direct the location for the PEWS.
- Check positions and preparations constantly. Look at them from the enemy's point of view, immediately correct deficiencies.
- Check soldiers' knowledge.

- Check dead space.
 - Check security.
 - Reconnoiter routes to and from alternate and supplementary positions, and routes used on a counterattack. Brief squad leaders and Bradley commanders.
 - Plan and conduct rehearsals of movement to and between primary, alternate, and supplementary positions.
 - Check the security and alert plan, the patrol plan, the radio watch, and the logistics.
 - Rehearse the counterattack plan.
 - Supervise.
- (b) **Platoon Sergeant.**
- Set up the MS chemical alarm.
 - Establish the platoon CP (and alternate CP), lay wire to squads, BFVs, OPs, attached elements, MAWS, and machine guns.
 - Send runner to guide wire from company to platoon.
 - Supervise the emplacement of BFVs, squads, MAWS, and machine guns.
 - Supervise preparation of range cards.
 - Request and allocate pioneer tools, barrier material, rations, water, batteries, and ammunition.
 - Help the platoon leader prepare the sector sketch.
 - Set up ammunition resupply point.
 - Set up EPW collection point.
 - Set up casualty collection point.
 - Coordinate medical support to include supplies for platoon aidman and combat lifesaver.
 - Designate latrine area and supervise the digging of the platoon slit trench.
 - Establish the security and alert plan, the radio watch, the sleep plan, and the PMCS schedule; brief the platoon leader.
 - Rest and conduct personal hygiene.
 - Supervise.

(c) *Bradley Commander.*

- Position BFV.
- Establish security (driver, gunner, or BC mans turret weapons system at all times unless told otherwise).
- Coordinate with left and right BFV and squad.
- Prepare range card.
- Boresight turret weapons system.
- Ensure wire is laid to the BFV.
- Issue rations, water, ammunition, pioneer tools, and barrier materials
- Pass additional information and changes to plans.
- Reconnoiter alternate and supplementary positions.
- Conduct maintenance on BFV.
- Supervise.

(d) *Squad Leader.*

- Establish local security.
- Ensure wire is laid to squad and BFV.
- Position squad, weapons, and soldiers; and assign sectors of fire.
- Ensure soldiers manning the OP have a position to return to.
- Draw a squad sector sketch and submit copy to platoon leader.
- Walk the position. Check sectors of fire, range cards, aiming stakes, and dead space by getting into each position and sighting weapons.
- Coordinate with left and right squad and BFV.
- Have soldiers begin digging after platoon leader checks position.
- Issue rations, water, ammunition, pioneer tools, and barrier material.
- Pass additional information and changes to plans.
- Supervise wire or mine teams.
- Give a warning order for planned patrol missions.
- Set up squad alert and security plan.
- Reconnoiter alternate and supplementary positions, routes, and counterattack plan with the platoon leader, then brief team leaders.
- Designate squad urine areas.
- Post and brief OPs.
- Rest and conduct personal hygiene.
- Supervise.

(e) Team Leader.

- Assist the squad leader as directed.
- Supervise.

b. Execution.

(1) The platoon leader or FO adjusts indirect fires as the enemy approaches.

(2) The platoon uses long-range fires to disrupt and channelize the enemy into engagement areas.

(3) The platoon destroys the enemy as he attempts to breach tactical obstacles.

(4) In controlling and distributing fires, the chain of command considers—

- The enemy's range.
- Engagement priorities.
- Method of engagement.
- Engagement and disengagement criteria.
- Mutual support.
- Distance to subsequent positions.

c. Consolidation. The platoon leader adjusts BFV and squad positions, if required, and reassigns sectors of fire. The platoon leader adjusts key weapons to cover most dangerous avenues of approach. The platoon leader positions OPs to provide early warning.

d. Reorganization. The platoon reestablishes the chain of command and fills key positions:

- (1) Reassigns key weapons.
- (2) Provides first aid and prepares wounded soldiers for evacuation.
- (3) Redistributes ammunition and supplies.
- (4) Reestablishes communications.
- (5) Evacuates EPWs.
- (6) Repairs damaged obstacles and positions.
- (7) Provides ACE report to the company commander.

APPENDIXES

1. ASSEMBLY AREA PROCEDURES
2. SMOKE PRODUCERS
3. LOAD PLANS

APPENDIX 1 (ASSEMBLY AREA PROCEDURES)
to
ANNEX C (OPERATIONS)
to
MECHANIZED INFANTRY PLATOON
TACTICAL SOP

An assembly area is used to prepare for future operations. The platoon normally occupies a portion of the company team assembly area. The assembly area is on defensible ground. It should provide concealment, room for dispersion, and good internal routes, as well as provide access to routes forward. Even though an assembly area is not expected to be a battle position, an all-round defense is organized with soldiers and equipment positioned or dug in to provide security from ground artillery and air attack. Leaders ensure that personnel continue to improve positions until they move out of the assembly area.

1. PRIORITY OF WORK. The following are normally done in order. For a more in depth list, see priority of work for the defense.

a. Establish Local Security. Establish local security by emplacing OPs with wire communications to the platoon. The MS chemical-agent alarm is emplaced up wind of the platoon position to provide early warning. At platoon positions, local security is maintained by alternating soldiers between work to security, this keeps roughly half the force providing security at all times.

b. Position Vehicles and Crew-Served Weapons. These should be placed where they can best be employed. If Dragons cannot be employed because of terrain restrictions, they should not be dismounted.

c. Establish Communications. Establish communications within the platoon and to the company CP. The platoon sets up a hot loop, connecting the squads to the platoon leader's vehicle by telephone (TA1/PT). To speed the establishment of telephone communications, the platoon leader can take a member of the platoon headquarters element with him to the company CP. As he returns to the platoon assembly area, a land telephone line can be reeled out from the company CP back to his vehicle. Also, the platoon leader has a person who knows where the company CP is should a messenger be needed. In the assembly area, radio-listening silence should be enforced.

d. Position Remaining Squad Members. Remaining squad members are positioned to provide security for crew-sewed weapons, to

cover dead space, and to cover avenues of approach. Dismounted infantry should initially prepare hasty fighting positions. When preparing positions, they clear fields of fire and tie in between squads and platoons so that uncovered gaps do not exist in the defense. The crew and squad prepare range cards for vehicle-mounted weapons and dismounted crew-served weapons, and the platoon leader prepares a platoon sector sketch and forward a copy to the company CP. The hasty fighting positions are then camouflaged by using the appropriate camouflage screens for vehicles and natural material for fighting positions.

e. Rest and Improve Defenses. Once the basics are accomplished, squads can alternate rest periods while working to improve the defense. Efforts to improve the defense include digging fighting positions and providing overhead cover, setting out remote sensors, and establishing security patrols.

2. ACTIONS IN ASSEMBLY AREAS. During and after the establishment of the defense, the following activities may take place:

- Leaders receive and issue orders.
- The platoon maintains its equipment and weapons.
- Personnel conduct personal hygiene.
- Leaders inspect.
- The platoon is resupplied to include distribution of ammunition and refueling of vehicles.
- The platoon rehearses critical aspects of the upcoming operation.
- Weapon systems are checked and small-arms weapons are test fired, if possible.
- Hoops eat and rest.
- Receives replacement or attachment.

APPENDIX 2 (SMOKE PRODUCERS)
to
ANNEX C (OPERATIONS)
to
MECHANIZED INFANTRY PLATOON
TACTICAL SOP

Smoke obscures vision and degrades most sighting devices. Both friendly and enemy forces use smoke to reduce their opponent's ability to see, move, and fight. Both use smoke to screen their own movement, and may place smoke to deceive. Thermal-imagery sights and viewers provide the means to see and shoot through most smoke.

1. ONBOARD SMOKE PRODUCERS. The BFV has onboard smoke generators, grenades, and a thermal-imagery sight to see through smoke. The smoke device is the M257 smoke grenade launcher.

a. The M257 smoke grenade launcher is used to spread a smoke screen quickly. There are two four-tubed launchers, one on each side of the turret. Eight smoke grenades are simultaneously launched electrically by the BC or gunner from the turret.

b. Four more smoke grenades are stowed in the ammunition box above each grenade launcher. The total number of rounds carried on the vehicle is 16. The launchers must be reloaded by hand from outside the vehicle.

c. The grenades are filled with red phosphorus. Upon activation, a dense cloud of white smoke is created from ground level up to a minimum height of 7 meters, by 70 meters wide, and between 20 and 50 meters from the vehicle. This takes 2 to 6 seconds. The cloud lasts from 1 to 3 minutes, depending on wind speed and other weather conditions.

d. Loading, stowing, reloading, and firing instructions for the grenade launcher are in TM 9-2350-252-10-2.

e. Smoke is a major factor on the battlefield. Measures should be identified and techniques practiced that allow the platoons and squads to use smoke, both enemy and friendly, to their advantage.

f. Smoke is also delivered by mortars and artillery. It is planned for and used to confuse, deceive, and degrade the enemy. Smoke pots can be carried on BFVs, they are positioned to support either the dismounted or BFV element.

2. TACTICAL CONSIDERATIONS IN A SMOKE ENVIRONMENT.

A platoon can use smoke to screen movement between positions; occupation of, withdrawal from, or reoccupation of positions; or in a counterattack. The smoke can also cover displacement between delay positions. It can deceive the enemy as to the location and number of vehicles employed on each position, and it can slow the enemy enough to let the platoon occupy new positions.

a. The limited number of smoke grenades makes it necessary for the platoon to take advantage of all other smoke sources and conserve smoke grenades for emergency self-defense. During movement, a platoon leader might direct a certain BFV to launch its smoke grenades to counter antiarmor fires. The 70-meter-wide smoke screen will probably not screen the entire platoon from the enemy. If not, the platoon leader could then direct another BFV to launch its smoke grenades. All vehicles must take evasive action to get full advantage from the smokescreen.

b. If a smoke screen is needed when crossing an open area, the smoke grenade launcher can be used to set up the smoke screen.

3. SMOKE COUNTERMEASURES. Smoke reduces the attacker's and the defender's ability to acquire targets, navigate, and control their forces. The use of smoke must be carefully planned to ensure that the intended advantage is gained. Detailed plans must be made, and everyone must know what actions to take in a smoke environment.

a. During movement, orient on terrain features, wood lines, riverbeds, and man-made features. Before smoke is employed, or when vision of the target or reference point is obscured, the gunner should lay the 25-mm gun on the target or reference point and turn on the stabilization system. The turret remains oriented in the general direction of the target or reference point. It does not point exactly at the target or reference point. The gunner must maintain constant pressure on the gunner's control palm grips without turning the turret while the stabilization is engaged.

b. Use of the thermal imagery sight to see through smoke must be planned by the platoon leader. The thermal sight requires a 10-minute cool-down period before it can be used. Because the thermal sight is used more commonly for acquisition, it should always be on when enemy contact is possible.

c. Smoke used to conceal movement is more effective when precautions and evasive actions are also used. Whenever possible, smoke should be produced from a covered or concealed position. A wood line or defilade position may be used to conceal the vehicles generating the smoke screen to cover an open area which must be crossed.

**APPENDIX 3 (LOAD PLANS)
to
ANNEX C (OPERATIONS)
to
MECHANIZED INFANTRY TACTICAL SOP**

Functional load plans are critical for combat operations. Weapons and equipment must be easily accessible. For routine load plans instructions, see TM 9-2350-252-10.

1. Rucksacks - secured to the bustle rack.
2. Concertina wire - secured on the side of the vehicle, but will be impractical in restrictive terrain. It may also be secured on the outside of the ramp, but it must not prevent the ramp access door from functioning.
3. Camouflage systems - secured to the trim vane. They are secured on the side opposite the driver and low enough so as not to hinder the driver's visibility.
4. MOPP gear - placed in a plastic bag and taped to the underside of the soldiers' seat. The suit is readily accessible and does not interfere with operations.
5. Bulky equipment used for periodic sustainment is not loaded on the BFV. Items such as a duffel bag are maintained on the company 2 1/2-ton supply truck. Duffel bags on the BFV are unmanageable and a safety hazard. Replenishment clothing or cold weather gear can be accomplished during scheduled resupply.

ANNEX D) (NBC) to INFANTRY TACTICAL SOP

1. REACT TO NUCLEAR ATTACK WITH OR WITHOUT WARNING.

a. With Warning. All soldiers take cover in a fighting position culvert, behind a hill, or in a BFV.

b. Without Warning. All soldiers assigned to the platoon react to an unwarned nuclear attack by doing the following:

(1) Mounted personnel get down in vehicle and close hatches, door, and ramp; lower blackout curtains over vision blocks.

(2) Dismounted personnel immediately drop to a prone position and close the eyes. Turn the body so the head faces toward the blast. Place the thumbs into the ears. Cover the face with the hands. Place the arms under the body. Tuck the head down into the shoulders and keep the face looking downward.

(a) Remain in the prone position until the second blast wave passes, and the debris has stopped falling.

(b) Check themselves and their buddies for injuries and damage to assigned equipment.

(c) Give first aid to any casualties and prepare them for evacuation.

(d) Report the situation to higher headquarters using the NBC 1 report.

2. REACT TO CHEMICAL ATTACK. All soldiers mounted or dismounted react to a chemical attack by doing the following:

a. Stop breathing and close eyes.

b. Within 9 seconds, put on the protective mask.

c. Within an additional 6 seconds, pull the hood over the head.

d. Shout "Gas" and give the appropriate arm-and-hand signal or use one of several audio alarms such as beating on metal or short blasts on vehicle horn.

e. Quickly dons protective overgarments.

3. UNMASKING PROCEDURES. Selected soldiers use the M256 kit to determine if the area is clear. If the area is clear, the platoon leader selects two soldiers and begins unmasking procedures. He moves the soldiers to a shady area and has the soldiers unmask for 5 minutes. He observes soldiers for 10 minutes. If no symptoms occur, he reports to higher headquarters; based on the response, he issues all clear. He continues to observe soldiers for delayed reactions.

4. HASTY DECONTAMINATION PROCEDURES. The platoon moves to the hasty decontamination site, designated by higher headquarters, and begins hasty decontamination procedures. The platoon uses two techniques: vehicle washdown and MOPP gear exchange.

a. Vehicle washdown removes gross contamination from vehicles and equipment. The procedures for vehicle washdown are—

- (1) Button up vehicle and equipment.
- (a) Close all doors, hatches, and other openings.
- (b) Put muzzle covers on weapons.
- (2) Washdown vehicle and equipment.
- (a) Spray hot soapy water on vehicle surfaces.
- (b) Washdown equipment.

b. MOPP gear exchange is always conducted in buddy teams in the following sequence:

- (1) Decontaminate gear.
- (2) Decontaminate hood.
- (3) Remove overgarment.
- (4) Remove overboots and gloves.
- (5) Put on overgarment.
- (6) Put on overboots and gloves.
- (7) Secure hood.
- (8) Secure gear.

ANNEX E (AIR DEFENSE) to MECHANIZED INFANTRY TACTICAL SOP

1. Report all enemy air activity.
2. Readiness posture:
 - a. White - Attack not probable. Use passive air defense measures, such as camouflage and concealment.
 - b. Yellow - Attack probable. Post air guards.
 - c. Red - Attack imminent or in progress. Man all weapons, be prepared to engage.
3. Weapon control status:
 - a. Weapons free - May fire at any aircraft which is not positively identified as friendly. This is the least restrictive status.
 - b. Weapons tight - May fire only at aircraft positively identified as hostile, according to the prevailing hostile.
 - c. Weapons hold - Fire only in self-defense, or in response to a formal order. This is the most restrictive status.
4. Engagement techniques: Active air defense is conducted in one of the following ways:
 - a. For a high-performance aircraft, soldiers aim at a point two football field lengths in front of the aircraft and fire on automatic. This makes the aircraft fly through a "wall" of bullets.
 - b. For a low-performance aircraft or a rotary aircraft, soldiers aim at a point half of a football field length in front of the aircraft and fire on automatic.
 - c. For any aircraft heading directly at the platoon, soldiers aim at a point directly above the nose of the aircraft and fire on automatic.

ANNEX F (FIRE SUPPORT) to MECHANIZED INFANTRY TACTICAL SOP

The platoon FO helps in planning and coordinating the platoon's indirect fire support plan.

1. **TARGETING.** Fires should be planned on—
 - a. Known or suspected enemy locations.
 - b. Prominent terrain features.
 - c. Dead space not covered by organic weapons.
 - d. Gaps between adjacent units not targeted by higher headquarters.
 - e. Likely mounted and dismounted avenues of approach.
 - f. Key terrain or obstacles not targeted by higher headquarters.
2. **FORWARD OBSERVER.** The FO is the platoon's link to the battalion fire support system. The FO must—
 - Be readily available to the platoon leader.
 - Maintain communications with the battalion FSO.
 - Be able to observe the battlefield.
3. **INDIRECT FIRE CONTROL.** Before the start of any operation, the platoon leader ensures the FO knows the following:
 - a. Target locations and descriptions.
 - b. The effects required or purpose of the target.
 - c. The priority of targets.
 - d. Target engagement criteria.
 - e. The method of engagement and control for the target.
 - f. The location of all TRPs, trigger lines, and any other fire control measure used by the platoon leader.
4. **CALL FOR FIRE.** The initial call for fire consists of three basic transmissions:
 1. Observer identification and warning order.
 2. Target location.
 3. Target description, engagement method, and fire control method.

ANNEX G (FIRE DISTRIBUTION AND CONTROL) to MECHANIZED INFANTRY TACTICAL SOP

The planning of direct fires to support movement and actions on the objective is based on METT-T.

1. **FIRE DISTRIBUTION.** The two types of targets are point and area.
 - a. Point targets require fires to concentrate on a particular target.
 - b. Area targets require fire distribution laterally and in depth.
2. **FIRE CONTROL.** Graphic control measures and firing patterns are used to effectively destroy targets and prevent fratricide.
 - a. **Graphic Measures.**
 - (1) Sectors.
 - (2) Boundaries.
 - (3) Battle positions.
 - (4) Engagement areas.
 - (5) TRPs.
 - (6) Trigger lines and break lines.
 - (7) Phase lines.
 - (8) Final protective line.
 - b. **Firing Patterns.**
 - (1) **Frontal fire.** Used when the enemy is moving perpendicular to the platoon's direction of fire. Each element engages the targets to their immediate front. Fires are shifted toward the center of the enemy.
 - (2) **Cross fire.** Used when the enemy is moving oblique to the platoon's direction of fire, or when terrain does not allow frontal fire. Targets are engaged from left to right, or right to left.
 - (3) **Depth fire.** Used when the enemy is moving parallel to the platoon's direction of fire. Targets are engaged from front to rear and rear to front. As targets are destroyed, fires are shifted toward the center of the enemy.
 - (4) **Near-half/far-half technique.** Used when the terrain is so open there is no specific feature to use as a reference point. The mounted element could be tasked to fire into the far end of the engagement area while the dismounted element fires into the near half of the EA.
 - c. **Engagement Priorities.** The platoon leader designates which targets he wants destroyed first by weapons system.

(1) **Antiarmor weapons systems.** Engage targets in the following order of priority.

- Most threatening armor.
- Armor in primary sector.
- Armor in secondary sector.
- Unarmored command and control vehicles.

d. Rules of engagement. Rules of engagement are directives issued by military or political authorities that specify circumstances under which the platoon will initiate or continue combat operations. Rules of engagement will generally be issued with the company operations order. Ensure everyone understands ROE.

e. Fire Control During Limited Visibility. During limited visibility, the following can be used to assist in controlling the platoon's fires.

- (1) Dragon trackers.
- (2) BFV thermal sights.
- (3) Ground surveillant" radar.
- (4) Aiming stakes.
- (5) Illumination.
- (6) Other night observation devices.

ANNEX H (OPERATIONS SECURITY) to MECHANIZED INFANTRY TACTICAL SOP

Operations security is the process of denying the enemy information about friendly capabilities and intentions. Measures to maintain operation security includes counterintelligence, physical security, signal security, and information security.

1. COUNTERINTELLIGENCE. Counterintelligence measures are taken to prevent the enemy from detecting the platoon by observation or electronic means. Camouflage and concealment and noise and light discipline are examples of counterintelligence.

a. Camouflage and Concealment. Camouflage is the use of natural and man-made materials to disguise and hide soldiers, vehicles, and equipment so they blend with their surroundings. Concealment is the use of available terrain features, both natural and made-made, to hide soldiers, vehicles, and equipment. Camouflage and concealment make it more difficult for the enemy to detect and engage platoons and squads with accurate fire.

(1) Camouflage can be attached to the BFV by communications wire or string. It should be used to break up the vehicle's outline, especially the turret. Camouflage on the turret must not interfere with the movement of the vehicle's weapons or block the view through the turret sights.

(2) Natural camouflage includes branches, grass, mud, or snow. Man-made camouflage includes wire netting, carpet, boards, or poles. Natural and man-made items may be used at the same time.

(3) When placing camouflage and concealment, platoons and squads must think about things the enemy will look for, or that will attract his attention to friendly positions. These include movement, shadows, obvious positions, shine or reflected light, shape, color, and concentration.

(a) *Movement.* Movement attracts attention, particularly vehicular movement. Even slight movements, such as arm-and-hand signals or a soldier walking, may attract the enemy's attention.

(b) *Silhouette.* Unusual shadows attract attention. Since the BFV is large and has a distinct shape, its shadow may be easily seen. Hence, every effort should be made to break up the vehicle's outline and cause its shadow to blend with shadows cast by natural terrain features. Shaded areas should be used to the maximum, but shadows move as the

position of the sun or moon changes. This should be taken into account by repositioning vehicles accordingly.

(c) *Obvious Positions.* Hilltops, road junctions, and lone buildings should be avoided. They are easily seen by the enemy and may be registration points for enemy indirect fire.

(d) *Shine or Reflected Light.* In daylight, bright or shiny surfaces will reflect sunlight and attract attention. At night, an exposed light, even one with a red lens, or the glow of a cigarette can be seen from far away.

(e) *Color.* Uniforms and vehicles are colored to blend with wooded surroundings. Often colors may not blend with the background. For example, if the ground is covered with snow, green camouflage will not blend. Adjust camouflage to fit local conditions.

(f) *Concentration.* Congestion of troops or vehicles in a small area will attract attention, and enemy fire. Soldiers and vehicles must always be dispersed.

b. Noise and Light Discipline. If a platoon does not practice noise and light discipline, the best operational security measures can be wasted. The most difficult noises to control are those made by the vehicles. They are also the most likely noises to be detected by the enemy. Several techniques can be used to decrease vehicle noises.

(1) When possible, keep night movement to a minimum because the BFV's engine and tracks can be heard at a considerable distance. Avoid idling engines at extreme speeds or moving vehicles rapidly. Close ramps and hatches before dark. When closing them after dark, do not slam them shut. After preparations have been made at night, inspect the vehicle from the outside to ensure there is no visible light being emitted.

(2) Vehicle light discipline includes—

- (a) Using vision block covers.
- (b) Using the driver's night vision viewer (AN/VVS-2).
- (c) Using night vision goggles.
- (d) Turning off all internal lights.
- (e) Using red filters on flashlights.

(3) Fire teams also must practice noise and light discipline. Noise discipline is simply avoiding loud noises, such as loud talking, laughing, or metal-on-metal sounds. Light discipline includes not smoking or building fires, and controlling use of flashlights.

2. **PHYSICAL SECURITY.** Physical security consists of actions taken to ensure the enemy does not close on or infiltrate friendly positions without being detected. It includes manning observation posts, conducting patrols, conducting stand-to, and providing local security.

a. **Observation Post.** Normally, a platoon is tasked to set up and man at least one two-man OP. In turn, the platoon leader designates a squad to perform OP duties. An OP is designed to observe to the most likely enemy avenue of approach or in the gaps between friendly positions. It provides early warning of the enemy's advance. Wire is the primary means of communication between the platoon headquarters and the OP.

(1) A fire team, with its Bradley and crew may be tasked to man an OP. This gives the OP more firepower, armor protection, better mobility, and better night vision optics.

(2) When a platoon leader establishes an OP, he must explain in detail what he wants the men to do, what actions they will take when they detect the enemy, and when and how they are to return to the platoon's position. The platoon leader may want to have the forward observer and his radiotelephone operator go with the squad personnel to call for indirect fire on any enemy detected.

b. **Patrols.** Normally, patrols are conducted to cover unoccupied gaps between defensive positions. On occasion, patrols also may cover the terrain between OPs. Squads or fire teams normally conduct patrols. Immediately following a patrol, all members are thoroughly debriefed by higher headquarters.

c. **Stand-To.** A stand-to is a period of maximum preparedness. It is conducted at first light in the morning and at darkness in the evening. A stand-to may be clone at other times as designated by the leader. This ensures the platoon is ready for action and that every man adjusts to the changing light conditions. Leaders check the following:

(1) All troops are awake, dressed, and ready for combat.

(2) All vehicles are topped off with fuel and stocked with a basic load of ammunition.

(3) All weapons have been cleaned, serviced, assembled, and ready for action.

(4) All radios are turned on and briefly tested.

(5) All vehicles are loaded to the extent possible, less the deployed fire teams, and are ready for short-notice moves.

d. **Local Security.** Local security consist of mounted and dismounted security.

(1) *Mounted security.* Mounted security is observing from the BFV and preparing the vehicle so that it does not become a security hazard. The platoon leader should assign each BFV an area to observe. The BC and gunner can best do this because they are elevated in the turret and have access to the BFV weapons' sights. In daylight, optical sights and binoculars are used. During evening stand-to preparations, the following steps should be taken:

- (a) Adhere to noise and light discipline measures.
- (b) Ensure the 25-mm gun and 7.62-mm coaxial machine gun ammunition boxes are fully loaded.
- (c) Activate and test the turret drive and turret stabilization.
- (d) Activate and test the ISU in the thermal mode.
- (e) Run the vehicle's engine enough to ensure the batteries are charged.

(2) *Dismounted security.* Dismounted local security is provided by the fire teams. During daylight, this involves observing in assigned sectors of defensive fires. At night, positions may be moved forward or closer to the vehicle element or to tanks in a company team. The infantrymen provide security by observing assigned sectors with the naked eye, binoculars, and nightsights. They also listen for the enemy. Tank crews and BFV crews have difficulty listening for the enemy because of vehicle noises and the crews' confined place in the vehicles.

3. SIGNAL SECURITY. Signal security includes measures taken to deny or counter enemy exploitation of electronic missions. It includes communications security and electronic security.

a. *Communications and Electronic Security.* At platoon and squad level, SIGSEC mainly concerns good communication procedures and electronic counter-countermeasures. ECCM are those actions taken to ensure friendly use of the electromagnetic spectrum against electronic warfare and includes antijamming, authentication, and radio discipline.

(1) As far as possible, the radio should be considered a communications backup. Arm-and-hand signals, flag signs, whistles, telephones, flashlight signals, and messengers are other available means.

(2) There will be times when the radio must be used. Platoons and squad should assume that the enemy is monitoring every radio transmission and using radio direction finders to locate transmitting radios. They also must assume that the enemy understands

English and can quickly break unauthorized codes. No matter who is transmitting, these rules should be followed—

- (a) Transmit only when necessary.
- (b) Think the message through and know exactly what needs to be said before keying the transmitter.
- (c) Keep transmissions short, and use call signs only as necessary.
- (d) Do not confuse the radio with vehicle intercom systems.
- (e) Use proper radiotelephone procedures and prowords.
- (f) Operate radios on low power as much as possible.

b. Encoded Information. In transmissions to the company commander and other platoons, the platoon leader often has information that needs to be encoded. In these situations, the platoon leader should use the signal operation instructions for the proper encoding procedures and authentication tables. Within the platoon, there seldom is occasion to send information that requires code; hence, transmissions are in the clear. Sensitive information should be passed orally in a face-to-face meeting of leaders or sent by messenger.

4. INFORMATION SECURITY. Information security includes measures taken to prevent the enemy from gaining intelligence about friendly units, intentions, or locations. Information security can be associated with physical security in that physical security may be necessary for good information security. During combat operations, foreign nationals and observers should not be permitted in the platoon's area. Specific instructions should be given to platoon members to deny local civilians access into or around their positions. Civilians could be used by the enemy to obtain information about the platoon.

a. Weapons, ammunition, classified documents, and sensitive items should be safeguarded at all times. When not in use, sensitive items should be stored out of sight. Careless equipment security can lead to compromise of platoon capabilities and limitations. If, for example, platoon movement is through a seemingly secure town, and with limited visibility devices and ammunition displayed, enemy infiltrators or sympathizers may obtain information about platoon capabilities.

b. Platoon vehicle markings and individual unit patches should be covered. This may seem insignificant, but they provide valuable information to the enemy. They allow the enemy to determine the size and type of platoon opposing them and the platoon's capabilities.

c. Censorship is practiced in wartime. Personal mail is inspected to avoid disclosure of valuable information. Soldiers should be briefed on what

not to include in their mail. Mail can be a valuable intelligence source. Examples of items that should not be in letters include—

- (1) Unit identification, size, location, or capabilities.
- (2) Knowledge of future operations.
- (3) Specific mention of commanders' names.
- (4) Acknowledgement of heavy losses or poor morale.

d. Whenever a platoon departs a position, a thorough police of the area should be conducted to ensure no item of intelligence value is left behind. Ammunition containers should not be left behind since they provide information as to the types and numbers of systems a platoon has. Food containers can indicate the platoon's size. Discarded radio batteries disclose communication capabilities. It is essential that platoon members police as they go.

ANNEX I (COMBAT SERVICE SUPPORT) to MECHANIZED INFANTRY TACTICAL SOP

Combat service support for mechanized infantry platoons consists mainly of maintenance, supply, personnel, and medical services. Most of this support comes from the company.

1. MAINTENANCE. The platoon leader's responsibilities include:

- Training operators.
- Inspecting.
- Assigning tasks within the platoon.
- Supervising all maintenance periods.
- Coordinating support requirements from higher headquarters.
- Following up on maintenance being performed outside the platoon.
- Ensuring maintenance on all weapons systems and equipment is performed in strict accordance with the appropriate -10 level technical manual.

2. SUPPLY. Resupply and refueling should be accomplished at every opportunity.

a. Methods of resupply.

(1) **Service-station method.** Supplies brought to a company resupply point and platoons rotate through.

(2) **Tailgate method.** The platoon is resupplied in position.

b. LOGPACs. These are planned resupply operations driven by the tactical setting. The battalion and company uses LOGPACs to push forward the various classes of supply needed by the platoon.

c. Request for Supplies. The platoon sergeant compiles a list of items needed and gives it to the company first sergeant who is the CSS operator.

3. PERSONNEL.

a. Strength Reports. Platoon strength is reported at least twice daily on a secure net or land line from the platoon battle roster.

b. Replacements. Care should be taken when integrating new soldiers into the platoon. They are briefed by their entire chain of command. Their equipment is inspected by their squad leader, and any problems that have surfaced during in-processing are immediately remedied.

Squad leaders explain the current situation and inform new soldiers of their duties and SOPs.

c. EPWs and Civilian Internees and Detainees. All EPWs and civilians are handled IAW with international law. The platoon leader monitors all activities dealing with EPWs and civilian internees and detainees. He ensures that they are searched, segregated, silenced, safeguarded and sped to the rear. He is in charge of providing their medical treatment and their physical security. In addition, he assigns a team or squad to help with this mission, and to help maintain control throughout this process.

4. HEALTH SERVICES.

a. Medical Evacuation. Each platoon contains at least one MOS qualified aidman. Every effort is made to train as many personnel as possible as combat lifesavers. However, their primary skills are as infantrymen not aidmen. Each squad appoints one man as an assistant aidman to help the platoon aidman with treatment of the casualties. The platoon sergeant coordinates with the platoon aidman and squad leaders for the location of the casualty collection point. The squad's chain of command is responsible for evacuating their troops to the location. Once the mode of evacuation has been established, the platoon sergeant secures the casualties, weapons, equipment, and ammunition and cross levels them, if need be. Requests for medical evacuation is handled by the platoon sergeant and routine sick is handled by the platoon aidman.

b. Field Sanitation. Field latrines are dug at least 100 meters from platoon positions, if the tactical situation permits. If not, the trench is constructed within the platoon perimeter. The trench is constructed under the supervision of the platoon aidman. The only water to be consumed by soldiers should be potable or treated water. If located near a stream, the latrine is constructed downstream from the platoon's positions.

APPENDIX A

ORGANIZATION

The platoon is the basic combat unit capable of maneuvering in the conduct of combat operations. The platoon can fight as part of a pure mechanized infantry company or as part of a company team, task-organized with tank platoons and mechanized infantry platoons. On the battlefield, the platoon can expect rapid and frequent movement. It must be prepared to fight in a variety of situations (mounted and dismounted) to include attacking defending delaying and moving, and during conditions when nuclear and chemical weapons have been used. The platoon operates to make maximum use of both the mounted and dismounted elements. The decision to fight mounted or dismounted and on how both elements will be used are made at platoon level. Once dismounted, the usual relationship is for all four BFVs, under the platoon sergeant's control, to support the squads. This aligns dismounted and mounted tasks, and facilitates command and control.

A-1. MOUNTED ELEMENT

The mechanized infantry platoon is equipped with four BFVs. The mounted element includes two sections (A and B) with two vehicles each—the section leader's vehicle and his wingman. One section may serve as the base of fire while the other section moves. Personnel seating is based on the principles that Leadership and area suppression weapons should be dismounted as early as possible (Figure A-1). 1st Squad, when mounted, rides in Section A BFVs, and 2d Squad rides in Section B BFVs (Figure A-2).

a. The platoon leader, his forward observer, and his assistant gunner ride in the platoon headquarters vehicle (BFV 1) in Section A. The platoon sergeant, aidman, and FO RATELO ride in the platoon sergeant's vehicle (BFV 4) in Section B. The platoon RATELO rides in BFV 2.

b. Team A, 1st Squad rides in BFV 1. Team B, 1st Squad and squad leader ride in the platoon leader's wingman vehicle (BFV 2). The BC of

BFV 2 is the platoon master gunner. His vehicle orients on the platoon leader's BFV. When the platoon leader dismounts, BFV 2 remains the wingman of BFV 1.

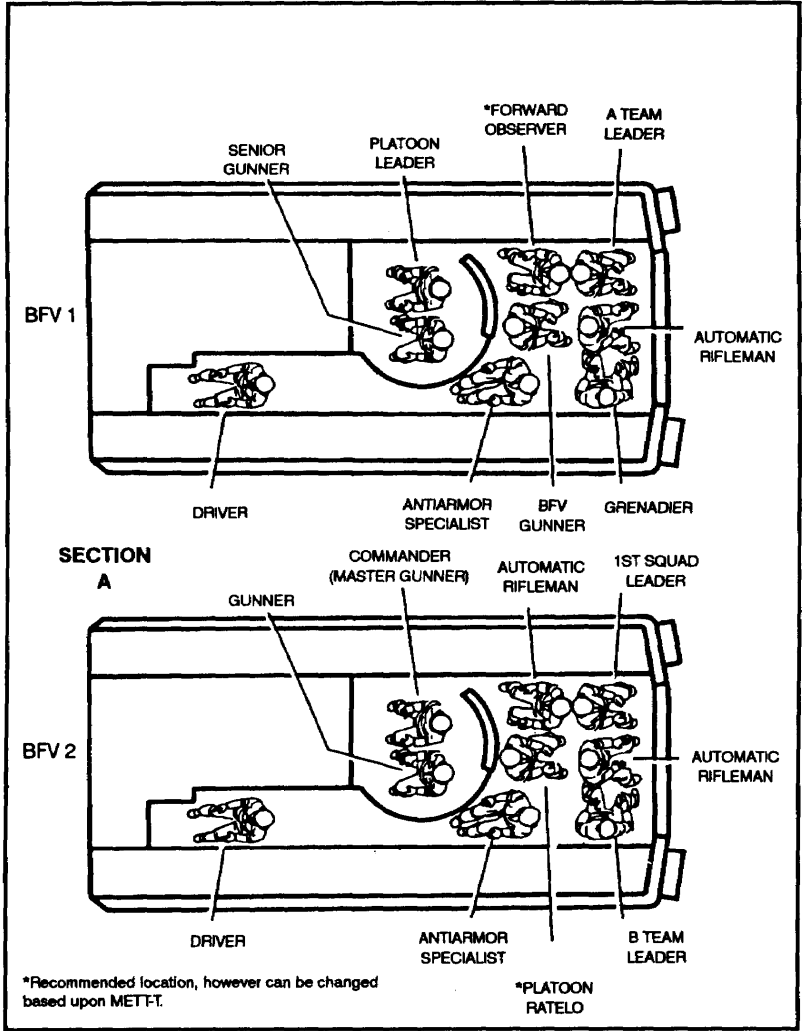

Figure A-1. BFV personnel seating.

c. The platoon sergeant is usually mounted and controls the mounted element. He may take control of the dismount element as needed. Team B, 2d Squad and squad leader ride in BFV 3. Team A, 2d Squad rides with platoon sergeant (BFV 4).

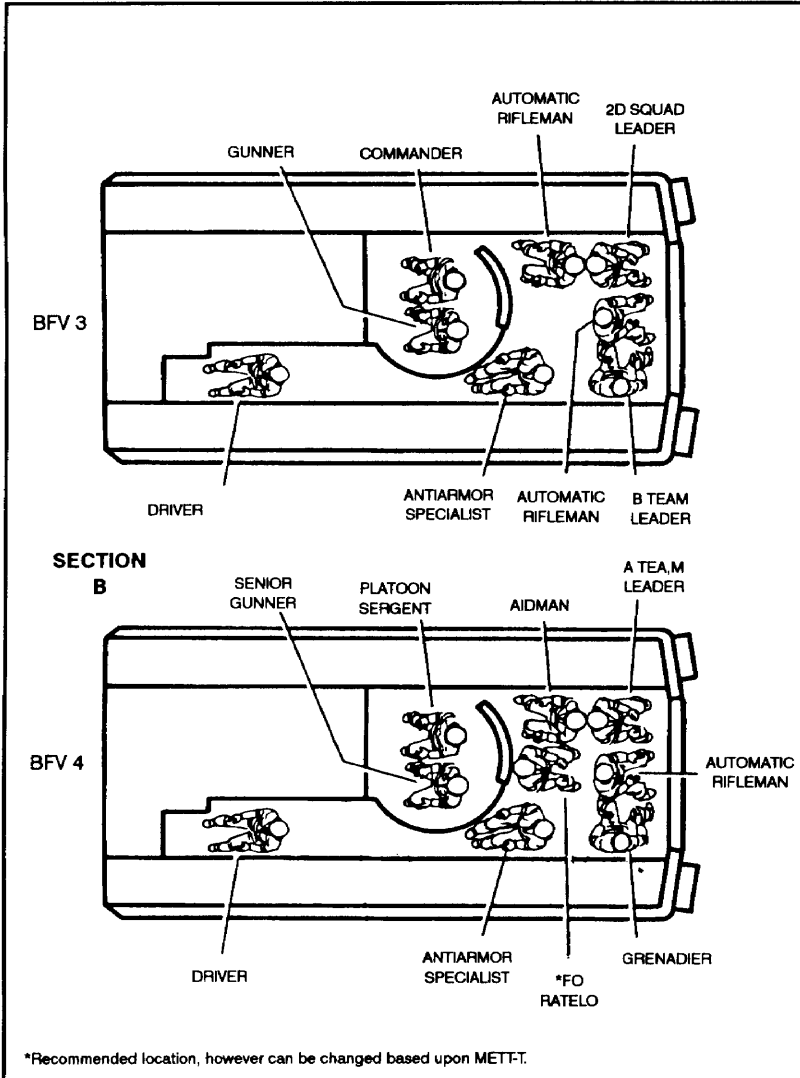

Figure A-1. BFV personnel seating (continued).

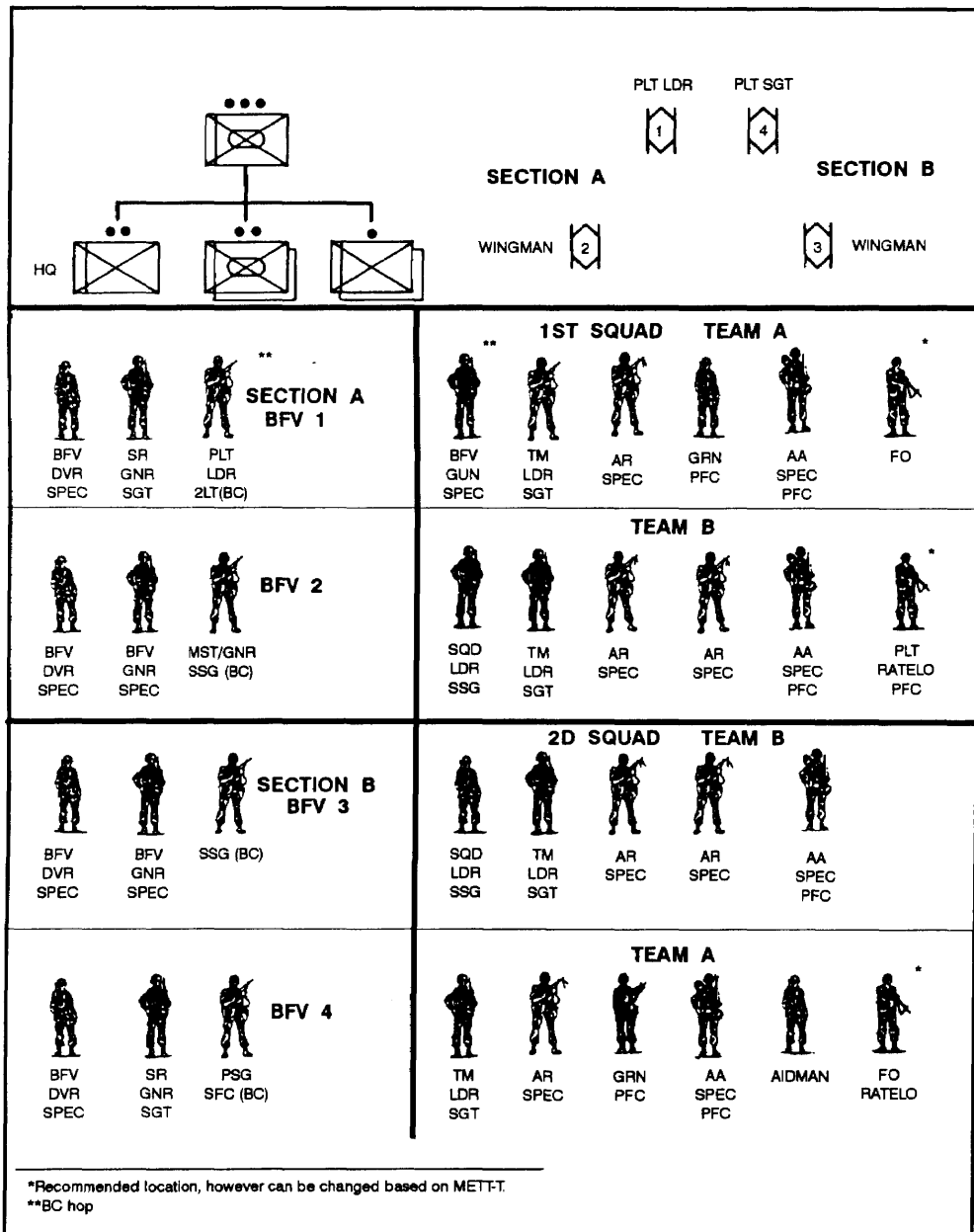

Figure A-2. Bradley Infantry platoon organization.

A-2. DISMOUNT ELEMENT

The dismount element consists of two squads of nine soldiers each including a squad leader and two team leaders. The leader of the dismount element is usually the platoon leader. The platoon sergeant may lead the dismount element when the mounted fight is the main effort and the situation dictates that the platoon leader remain mounted. The BFVs serve as the base of fire for the dismount element. The squads have the capability of setting up a base of fire to fire and move. A squad can also provide its own overwatch element and conduct independent fire and maneuver when required.

a. The senior gunner in the platoon leader's vehicle becomes the BC when the leader dismounts. Upon dismounting, the platoon leader's assistant gunner moves to the gunner's seat. Should the platoon sergeant dismount, the senior gunner becomes the BC. The platoon sergeant must have a trained gunner designated from the fire team in his vehicle. This position should be resourced, and the individual qualified as part of an alternate crew with the senior gunner as the BC.

b. If a dismount is executed in response to an unexpected, life-threatening situation where speed is essential, then only the squads dismount. The BFVs immediately suppress and obscure the enemy while moving to covered dismount points. A quick estimate is made to determine if and when the platoon leader joins the dismount element. Until that time, the senior squad leader controls the dismount element to develop the situation, to provide local security, or to reconnoiter. When the platoon leader dismounts, the senior squad leader performs platoon sergeant duties as designated by the platoon leader.

c. The ability of the squads to fight independently from the BFVs offers the platoon leader and company commander numerous employment options. Because the BFVs can fight effectively when the fire teams dismount, the platoon can fight as two separate elements. The distinct characteristics and advantages provided by the separate elements are simultaneously reinforcing and complementary to one another.

A-3. DUTIES AND RESPONSIBILITIES

The BFV requires a fully trained crew. It carries a fire team whose primary role is to dismount and fight on the ground. The leadership of the BFV-equipped platoon is balanced between the fighting vehicles and the two squads. Leader's roles are complex to accommodate this powerful and flexible capability. Each member of the platoon must be trained and prepared to perform his duties. The organization provides for career progression and depth. There is a mounted and dismounted

function and job position for each skill level throughout the platoon. It provides for well-rounded soldiers who can fill voids created by personnel losses in combat or personnel turbulence (changes) or shortfalls in peacetime.

a. Platoon Leader. He is responsible for all that the platoon does or fails to do. This includes the tactical employment, collective training, administration, personnel management, and logistics of his platoon. He must know his soldiers and how to employ the platoon's weapons. He is personally responsible for positioning and employing all assigned or attached weapons. He must also know how to employ supporting weapons. The platoon leader—

- (1) Serves as BC and section leader when mounted.
- (2) Normally dismounts when the situation causes the platoon to dismount.
- (3) Sets the example and the standards.
- (4) Leads the platoon to support the company and battalion missions. He bases his actions on the mission the company commander assigns him, the concepts of the company and battalion commanders, and his own estimate of the situation.
- (5) Informs his commander of his actions when operating without orders.
- (6) Plans with the help of the platoon sergeant, squad leaders, and other key personnel (FO, leaders of attachments, and so on).
- (7) Stays abreast of the situation and goes where he is needed to supervise, issue FRAGOs, and accomplish the mission.
- (8) Requests more support for his platoon from the company commander to perform its mission, if needed.
- (9) Assists the platoon sergeant in planning and coordinating the platoon's CSS effort.
- (10) During planning, receives on-hand status reports from the platoon sergeant, squad leader, or both.
- (11) Reviews platoon requirements based on the tactical plan.
- (12) Develops a casualty evacuation plan.
- (13) During execution, checks the work of the platoon sergeant and squad leaders.

b. Platoon Sergeant. He is the senior NCO in the platoon and second in succession of command. He helps and advises the platoon leader, and leads the platoon in the platoon leader's absence. He supervises the platoon's administration, logistics, and maintenance. He may prepare and issue paragraph 4 of the platoon OPORD. The platoon sergeant is responsible for individual training. He must ensure that soldiers can perform their individual MOS tasks. He advises

the platoon leader on appointments, promotions and reductions, assignments, and discipline of NCOs and enlisted soldiers in the platoon. The platoon sergeant—

- (1) Serves as BC and section leader when mounted.
- (2) In some instances, commands and controls the dismount element.
- (3) Controls the mounted element when the platoon leader dismounts.
- (4) Receives Bradley commanders, squad leaders' administrative, logistical, and maintenance reports and requests for rations, water, fuel, and ammunition. He works with the company's first sergeant or XO to request resupply. He also directs the routing of supplies and mail.
- (5) Directs the platoon aidman and platoon aid and litter teams in moving casualties to the rear.
- (6) Maintains platoon strength information, consolidates and forwards the platoon's casualty reports (DA Forms 1155 and 1156), and receives and orients replacements.
- (7) Monitors the morale, discipline, and health of platoon members.
- (8) Takes charge of task-organized elements in the platoon during tactical operations. This can include, but is not limited to, the following.
 - Quartering parties.
 - Security forces in withdrawals.
 - Support elements in raids or attacks.
 - Security patrols in night attacks.
- (9) Coordinates and supervises company-directed platoon resupply operations.
- (10) Ensures that supplies are distributed IAW the platoon leader's guidance and direction.
- (11) Ensures that ammunition and supplies are properly and evenly distributed (a critical task during consolidation and reorganization).
- (12) Ensures that the casualty evacuation plan is complete and executed properly.

c. **Bradley Commander.** The BC remains mounted and is responsible for commanding the vehicle in relation to the section and platoon. He is responsible for acquiring targets, issuing fire commands, laying the gun for deflection, and controlling vehicle fires to include firing port weapons. The BC is primarily responsible for the overall maintenance of the BFV's weapons systems and the automotive and turret portion of the vehicle. He is also responsible for the weapons training and welfare of the crew. The BCs on BFVs 2 and 3 are responsible for the training, health, and welfare of the crews of the two BFVs in their sections.

d. Squad Leader. There are two squads each led by a staff sergeant. Their squads are habitually associated with a vehicle section. The senior dismounted squad leader is also responsible for the employment of the dismount element until the platoon leader or PSG arrives. He is responsible for all that the squad does or fails to do. He is a tactical leader and, as such, leads by example. The squad leader—

(1) Assists the BC in maintaining the BFVs.

(2) Controls the maneuver of his squad and its rate and distribution of fire. To do this, he controls two fire teams in the offense; selects each fighting position in the defense; and gives the proper commands, codes, and signals to start, stop, and shift fires.

(3) Trains his squad on the individual and collective tasks required to sustain combat effectiveness.

(4) Manages the logistical and administrative needs of his squad.

He requests and issues ammunition, water, rations, and special equipment.

(5) Maintains accountability of his soldiers and equipment.

(6) Completes casualty feeder reports and reviews the casualty reports completed by squad members.

(7) Submits requests for awards and decorations.

(8) Directs the maintenance of the squad's weapons and equipment.

(9) Inspects the condition of soldier's weapons, clothing, and equipment.

(10) Ensures that material and supplies are distributed to the soldier in the squad.

(11) Keeps the platoon leader and platoon sergeant informed on squad supply status and squad requirements.

(12) Ensures supplies and equipment are internally cross-leveled within the squad.

e. Platoon Master Gunner. The platoon master gunner is the BC for BFV 2 and the platoon leader's wingman. He is the platoon leader's technical expert on gunnery and turret weapons systems. During combat or field exercises, he advises the platoon leader and PSG on BFV weapons effects, capabilities, and safety. He advises on fire control measures and preparation. He is the key technical trainer of the mounted element under routine supervision of the platoon sergeant. He helps the platoon leader establish the gunnery task for training.

f. Team Leader. Two fire team leaders are in each squad. They perform the same functions as team leaders in all infantry rifle squads and are habitually associated with a specific BFV. They assist the squad leader in the tactical control of the squad. They lead by example. They control the movement and fires of the fire teams. They must keep the soldiers in the

troop compartment well informed and alert. They assist the squad leader in training team members on the individual and collective tasks and battle drills. Team members provide the necessary local security and maintenance support for the BFV. They are responsible for the welfare of their teams.

g. Gunner. The gunner observes the battlefield to detect enemy targets. He operates the turret weapons as directed by the BC. The gunner is responsible for verifying the identification of targets before engaging. He serves as gunner and, in rare cases, as BC when only two men are in the BFV. He is responsible for operator maintenance of the turret and its weapons. The gunners for the platoon leader and platoon sergeant are often required to assist in navigation and operation of radios.

h. Driver. The driver drives the vehicle under the BC's control. He follows terrain-driving procedures and tries to select hull-down positions. He also aids in detecting targets and observing rounds fired. He assists in navigation by monitoring odometer readings and observing terrain. The driver is primarily responsible for operator maintenance of vehicle automotive systems. (Other squad members help the driver as directed by the platoon leader or platoon sergeant.)

i. Antiarmor Specialist. The antiarmor specialist's primary weapon is the M16A2 rifle. He is also the designated gunner for the Dragon and AT4.

j. Grenadier. The grenadier's primary weapon is the M16A2 rifle equipped with the M203 grenade launcher.

k. Automatic Rifleman. The automatic rifleman's primary weapon is the M249 machine gun. The Bradley squad has three automatic riflemen.

l. Platoon Aidman. The platoon aidman helps the platoon sergeant direct aid and litter teams; he monitors the health and hygiene of the platoon. The platoon aidman—

(1) Treats casualties and assists in their evacuation under the control of the platoon sergeant.

(2) Aids the platoon leader or sergeant in field hygiene matters, and personally checks the health and physical condition of platoon members.

(3) Requests Class VIII (medical) supplies through the platoon sergeant.

(4) Provides technical expertise and supervision of the combat lifesavers.

(5) Carries out other tasks assigned by the platoon leader and platoon sergeant.

m. Platoon Radiotelephone Operator. The platoon RATELO must know the use and care of the radio to include waterproofing and presetting frequencies, the use of the SOI, and how to construct and erect field-expedient antennas.

n. Fire Support Team. The company has a fire support team attached from the DS FA battalion. This team provides each platoon with a two-soldier FO party—an FO and his RATELO.

(1) **Forward observer.** The FO acts as the eyes of the FA and mortars. He works for the platoon leader. The FO's main responsibilities are to locate targets and to call for and adjust indirect fire support. The FO must be familiar with the terrain that the platoon is operating in and the tactical situation. He must know the mission, the concept, and the platoon's scheme of maneuver and priority of fires. The FO must—

- Inform the FIST headquarters of platoon activities and the fire support situation.
- Prepare and use situation maps, overlays, and terrain sketches.
- Call for and adjust fire support.
- Operate as a team with the RATELO.
- Select targets to support the platoon's mission based on the company OPORD, platoon leader's guidance, and an analysis of METT-T factors.
- Select OPs and movement routes to and from them.
- Maintain communications as prescribed by the FSO.
- Operate the digital message device.
- Maintain the six-digit grid coordinates of his location.

(2) **Radiotelephone operator.** The RATELO's main duties are to set up, operate, and maintain the FO party's communication equipment. At times, he must also perform the duties of the FO for the platoon.

APPENDIX B
**BRADLEY PLATOON REFERENCE
GUIDE**

To succeed in combat, infantrymen must know their equipment and be experts in employing their organic and supporting weapons.

B-1. CHARACTERISTICS

A detailed list of characteristics for each model of the Bradley is in Table B-1, page B-2.

CHARACTERISTIC	M2/M2A1	M2A2
Weight (Cbt-lbs):	50,259/50,261	66,000
Ground Pressure (psi):	7.7	9.3
Fuel Capacity (gal):	175	175
Cruising Range (mi/km):	300/483	250/400
Engine (Cummins):	VTA-903T	VTA-903T
Gross Horsepower (hp):	500	600
Gross hp-to-wt (tons):	20.62	18.2
Transmission (GE HMPT):	500	500-3
Speed (mph/kph):		
Land:	41/66	38/61
Water:	4.5/7	4.0/6.4
Slope Climb:	60%	60%
Slide Slope:	40%	40%
Trench Crossing:	8' 4"	8' 4"
Vertical Wall Climb (inch):	36	36
Personnel Capacity:		
Mounted Crew:	3-man	3-man
Dismounted:	6-man	6-man
Firing Ports:	6	2 in ramp
TOW/TOW 2 missile		
Variant:		TOW 2
# Launcher:	2	2
# Stowed:	5	5*
25-mm ammunition:		
# Ready:	300	300
# Stowed:	600	600
M240C coax ammunition:		
# Ready:	800	800
# Stowed:	1400	1400
M249 7.62 ammunition		
# Stowed:	2200	2200
M231 FPW 5.56 ammunition:		
# Stowed:	4200	2520
M16 5.56 ammunition:		
# Stowed:	2520	2520
LAW		
# Stowed	3	3
PRODUCT IMPROVEMENT TO M2AO (BASIC)		
M2A1(-)	M2A1	M2A2
Gas Particulate	TOW 2 Subsystem Digital	Applique armor
Filter System with	Command Guidance	DCGE
Ventilated Face Piece	Electronics	Spall Linner
Weapons System Interlock	(DCGE)	Ammo Restowage
Ammo Restowage		
Armor Covers for Periscope		
Fuel System Revised		
Fire Suppression System Revised		
*Based on the number of Dragons carried.		

Table B-1. Bradley fighting vehicle data.

TOTAL PRODUCTION		
M2A0 (BASIC)	2,300	NOTE:
M2A1 (-)/M2	1,371	TOW — BGM71A Basic TOWs
M2A1	3,053	TOW — BGM71C Improved TOW
M2A2**		TOW 2 — All TOW Models
		TOW 2A
**Planned acquisition — 6,724		

Table B-1. Bradley fighting vehicle data (continued).

B-2. CREW AND TROOP COMPARTMENTS

The BFV carries nine soldiers. The BC and the gunner ride in the turret. The driver occupies the left front station. The fire team rides in the rear (troop compartment). The soldiers can view a portion of the battlefield through the vision blocks. The BC and the gunner can operate all the turret weapons. Soldiers can mount or dismount the vehicle through six points: commander's hatch, gunner's hatch, driver's hatch, cargo hatch, ramp access door, and ramp (Figure B-1).

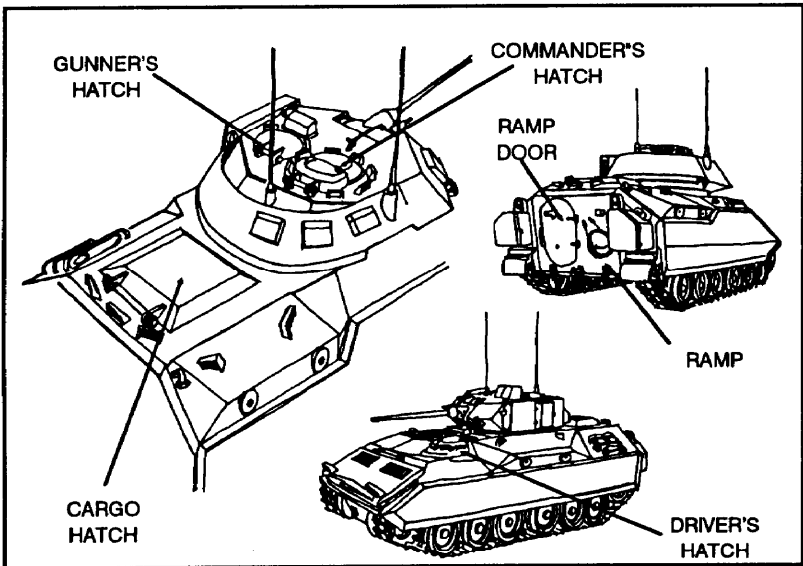

Figure B-1. BFV dismount points.

B-3. MOBILITY

The BFV has excellent acceleration, agility, and cross-country speed of 48 kilometers per hour, with a cruising range of 483 kilometers. The BFV's mobility provides an ability to move quickly on the battlefield and work in concert with the M1 main battle tank.

B-4. ARMOR PROTECTION

Through the use of special armorplate materials, surface slope, and a unique laminate armor system, the BFV has excellent armor protection for its weight. Even though the BFV's armor does not compare to that of a tank, the BFV can withstand 14.5-mm projectiles on all sides; the M2A2 Bradley can withstand projectiles up to 30-mm.

B-5. ORGANIC WEAPONS

The Bradley platoon has mounted and dismounted organic weapons.

a. Mounted Weapons. The vehicle's main armament is a 25-mm fully automatic, externally powered gun. The BFV's armament also includes a two-tube antitank missile launcher (TOW), a 7.62-mm coaxially mounted machine gun, and 5.56-mm firing port weapons. The all-electric, fully stabilized turret permits accurate fire even when the vehicle is moving over rough terrain. The turret can also be operated manually (see TM 9-2350-252-10-2 and TM 9-2350-284-10-2).

(1) **M242 25-mm gun.** The 25-mm gun has three rates of fire—single shot, low rate, and high rate. It accurately delivers both armor-piercing and high-explosive rounds. The 25-mm gun using APDS-T rounds can destroy lightly armored vehicles (BMP, BTR, BRDM). Using HEI-T rounds, it can destroy unarmored vehicles (trucks, jeeps) and suppress enemy troops in the open, in built-up areas, or in dug-in positions.

(a) The 25-mm APDS-T round can penetrate lightly armored vehicles. Flank shots increase the probability of penetration. Maximum effective range/tracer burnout is about 1,700 meters, but effective fire using sabot rounds can be achieved by using burst-on-target techniques if impact of the round can be observed.

(b) The 25-mm APFSDS-T is a fixed-type, percussion primed round. It consists of a sabot encapsulated projectile crimped to a steel cartridge case. Basic operation of this kinetic energy round is the same as APDS-T with an increase in velocity to about 1,420 meters per second. This round has increased penetration capabilities as well as tracer burn time, which allows engagement of targets at longer ranges and with greater potential to defeat a BMP-2.

(c) The HEI-T is excellent for suppressing antitank guided missile crews and crew-served weapons out to 3,000 meters. Tracer burnout is 2,000 meters, but effective fire can be placed on targets at further ranges

if impact of the round can be observed. HEI-T has a 5-meter bursting radius that enables this ammunition to be used in both point and area target engagements.

(d) The BFV can carry onboard 900 rounds of 25-mm ammunition; only 300 can be loaded in the 25-mm ammunition cans. Uploading the weapons system for the 25-mm takes about 15 minutes. All leaders and gunners must be aware of the operational impact of using all of the ammunition in the ammunition cans. As ammunition is fired, 15-round belts can be linked and loaded in the two ammunition cans in just minutes. If all ammunition is used, reloading takes 12 minutes because the new ammunition must be fed directly into the gun. This is difficult to do while the vehicle is moving.

DANGER

TO PREVENT FRATRICIDE, APDS-T AMMUNITION IS NEVER FIRED WHILE DISMOUNTED SOLDIERS ARE WITHIN A GUN ARC OF 10 DEGREES AND WITHIN 400 METERS UNLESS OVERHEAD COVER IS AVAILABLE. PIECES OF METAL OR PLASTIC THAT FALL OFF THE ROUND COULD INJURE OR KILL SOLDIERS.

(2) **TOW launcher.** The TOW missile is an accurate antitank weapon from 65 to 3,750 meters. Two TOW missiles are loaded in the turret-mounted launcher. There is internal space for stowing five missiles, either TOW missiles or Dragons or a mix. The TOW is best fired at the flank or rear of tanks at ranges between 1,500 and 2,500 meters to reduce the flight time of the missile and provide the best attack profile of the vehicle. Frontal shots should be avoided against tanks. Against lightly armored vehicles, the range and the target aspect are not as critical (Table B-2, page B-7).

DANGER

THE BFV MUST BE LEVEL AND STATIONARY FOR THE TOW TO BE FIRED. BEFORE FIRING THE TOW, THE DRIVER, GUNNER, AND BC MUST CHECK THE SLOPE INDICATORS AT THEIR STATIONS. SOLDIERS COULD BE INJURED OR KILLED, EQUIPMENT COULD BE DAMAGED, AND THE MISSILE COULD BE LOST

(a) The TOW missile can destroy targets at a minimum range of 65 meters up to a maximum range of 3,750 meters.

- I-TOW, an improved TOW missile (BGM-71C), has a 5-inch warhead that includes an extended probe to provide detonation at a greater standoff distance from the target, which increases penetration.
- TOW 2 (BGM-71D) has a 6-inch full-caliber warhead that also includes an extensible probe to enhance penetration, including applique armor.
- TOW 2A (BGM-71E) has all the capabilities of the TOW 2 missile, however, it contains an explosive charge in the tip of the probe to defeat reactive armor to allow main warhead penetration.
- TOW 2B (BGM-71F) provides a flyover shoot-down (top attack) capability that attacks the most vulnerable part of an armored vehicle.
- The basic TOW, practice (BTM-71A), has an inert warhead and is the standard training round.

TYPE	DESIGNATOR		MAX FLIGHT RANGE (METERS)	WARHEAD
	HEAT	INERT PRACTICE		
BASIC TOW	BGM-71A	BTM-71A	3,000	5-inch unitary ¹
BASIC TOW	BGM-71A-1	BTM-71A-1	3,000	5-inch unitary
BASIC TOW	BGM-71A-2	BTM-71A-2	3,000	5-inch unitary
BASIC TOW	BGM-71A-3	BTM-71A-3	3,750	5-inch unitary ²
IMPROVED TOW	BGM-71C	NONE	3,750	5-inch unitary with probe
IMPROVED TOW	BGM-71C-1	NONE	3,750	5-inch unitary with probe
TOW 2	BGM-71D	NONE	3,750	6-inch unitary with probe ³
TOW 2A	BGM-71E	NONE	3,750	6-inch tandem with probe tip charge ^{2,3}
TOW 2B	BGM-71F	NONE	3,750	Flyover, shoot down
¹ link (wire) breaks.				
² subsystem.				
³ allows the main 6-inch warhead to penetrate the basic hull armor.				

Table B-2. TOW missile data.

(b) The improvement of Threat vehicle armor protection has resulted in improved TOW missiles. Table B-3 recommends the best TOW missile to use against various type targets. In all cases, flank shots increase the probability of a single shot kill and minimize detection or engagement from the Threat armor.

THREAT VEHICLE Type Targets	TOW MISSILE SELECTION PRIORITY			
	First	Second	Third	Fourth
TANKS WITH APPLIQUE ARMOUR	TOW 2	TOW 2A	TOW 2B	I-TOW
TANKS WITH EXPLOSIVE REACTIVE ARMOR	TOW 2B	TOW 2A	TOW 2	I-TOW
TANKS WITHOUT APPLIQUE OR REACTIVE ARMOR	I-TOW	TOW 2	TOW 2A	TOW 2B
LIGHT-ARMORED PERSONNEL CARRIERS	I-TOW	TOW 2	TOW 2 A	TOW 2B
LIGHT-ARMORED WHEELED VEHICLES	I-TOW	TOW 2	TOW 2A	TOW 2B
ANTIAIRCRAFT VEHICLES	I-TOW	TOW 2	TOW 2A	TOW 2B
ARMORED VEHICLES IN HULL-DEFILADE POSITION	TOW 2B	TOW 2A	TOW 2	I-TOW
BUNKERS AND FORTIFICATIONS	I-TOW	TOW 2	TOW 2A	

Table B-3. Missile selection.

(c) The perception of standoff to mean “engage armor vehicles beyond 2,000 meters to maximum range (3,750 meters)” is not always tactically feasible for the following reasons:

- Tracking time beyond 2,000 meters increases the likelihood of gunner error and provides the enemy additional reaction time to maneuver against the position.
- The probabilities of hit at extended ranges are significantly lower, especially through thermal sights and obscuration.
- Ranges beyond 2,000 meters decrease the probability of flank shot hits due to extended tracking time, increased speed capability of modern vehicles, and terrain restrictions.

(3) **M240C 7.62-mm coaxial machine gun.** The 7.62-mm coaxial machine gun is an accurate and reliable weapon. The main use of this weapon is against dismounted forces. It can also be used to suppress crew-served weapons and engage unarmored vehicles and aircraft out to 900 meters (tracer burnout). The BFV can carry 2,200 rounds of 7.62-mm coax ammunition—1,400 stowed and 800 ready.

DANGER

BEFORE FIRING THE FPWs, THE BFV CREW SHOULD ENSURE SERVICEABILITY AND OPERATION OF EXHAUST HOSE AND FANS TO REMOVE POISONOUS GASES FROM THE TROOP COMPARTMENT.

(4) **M231 5.56-mm firing port weapons.** The basic BFV and M2A1 have six M231 5.56-mm FPWs—two on each side, two in the ramp. (Figure B-2, page B-10.) The M2A2 has only the two ramp FPWs. These weapons provide close-in protection and suppression out to 300 meters. The M2A1 carries 4,200 rounds of ammunition for the FPWs; the M2A2 carries 2,520 rounds.

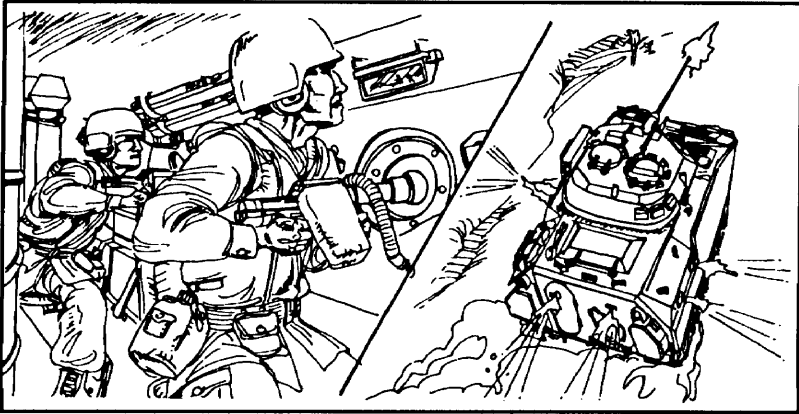

Figure B-2. Firing port weapons.

b. Dismounted Weapons. The weapons for the two squads are two Dragons, six M249 machine guns, six grenade launchers, six rifles (one M24 sniper weapon can be provided by the company), one AT4, grenades, and mines. The vehicle has stowage space for 2,520 rounds of 5.56-mm ammunition for the rifles and machine guns. This figure does not include the ammunition the soldiers may carry in the LBE. All leaders must know how to employ these weapons effectively (Table B-4).

INDIVIDUAL WEAPONS				
	M9 PISTOL	M16A2	M249 MG	M203 GL
WEIGHT (lbs)	2.6	8.7	15.5	11
LENGTH (in)	8.5	39	41.1	39
MAX RANGE (m)	1,800	3,600	3,600	400
ARMING RANGE (m)	N/A	N/A	N/A	14
MIN SAFE RANGE (m)	N/A	N/A	N/A	31
RATE OF FIRE				
CYCLIC (rpm)	N/A	700-800	800	N/A
RAPID (rpm)	N/A	N/A	200*	35
SUSTAINED (rpm)	60	16	85	35
EFFECTIVE RANGE				
AREA (m)	N/A	800	800	350
POINT (m)	50	580	600	160
MOVING (m)	N/A	200	N/A	N/A
AMMUNITION				
TYPE	BALL	BALL, TRACER, DUMMY, PRACTICE, and BLANK	BALL, TRACER, DUMMY, PRACTICE, and BLANK	HE, WP, CS, ILLUM, TP, and BUCKSHOT
EXAMPLE LOAD (rds)	30	210	600	
*With barrel change				
ANTIARMOR WEAPONS				
	M72 LAW	M136 AT4	M47 DRAGON	
WEIGHT (lbs)	4.7	14.8	68.5	
LENGTH (in)	22/35	40	44	
MAX RANGE (m)	1,000	2,100	1,000	
ARMING RANGE (m)	10	10	65	
MIN SAFE RANGE (m)	30	30	65	
EFFECTIVE RANGE				
STATIONARY (m)	200	300	1,000	
MOVING (m)	125	300	100	
BACKBLAST (m)	50	100	50	

Table B-4. Dismounted weapons.

HAND GRENADES and MINES				
	FRAG	WP	THERMITE	CONCUSS
WEIGHT (lbs)	1	2	2	1
RANGE (m)	40	30 (Thrown by average soldier)	25	40
PACKING (box)	30	N/A	16	20
BURST RADIUS (m)	15	17 60-sec burn	40-sec burn	2
	M21 ANTITANK MINE	M14 ANTIPERS MINE (Toe Popper)	M16A1 ANTIPERS MINE (Bouncing Betty)	M18A1 ANTIPERS MINE (Claymore)
WEIGHT (lbs)	18	3.6	8.3	3.5
PACKING (box)	4 mines 4 fuzes	90 ea mines and deton	4 fuzes tripwire	6 mines w/accy
BURST RADIUS	1 tank	1 indiv	30 m	50 m (eff) 250 m (max)

Table B-4. Dismounted weapons (continued).

B-6. COMMUNICATIONS

The BFV's communication system provides for control of mounted and dismounted operations. Tables B-5 and B-6 and Figures B-3 through B-5, page B-14, depict the arrangement of communication equipment and the radio net configuration within the platoon. As units update their communication system, they will have the single-channel ground/airborne radio system (SINCGARS) as shown in Table B-6.

	BFV 1	BFV 2	BFV 3	BFV 4	Total
VRC-46 (ND)	1			1	2
AN/GRC-160 (M/D)	1			1	2
AN/GRC-64 (M/D)		1	1		2
PRC-77 (D)	1				1
INTERCOM	1	1	1	1	4
Total	4	2	2	3	11

Table B-5. Communication equipment.

	BFV 1	BFV 2	BFV 3	BFV 4	Total
VRC-87 (ND)		1	1		2
VRC-91 (M/D)	1			1	2
PRC-119 (D)	1				1
PRC-126 (D)	1	1	1	1	4
INTERCOM	1	1	1	1	4
Total	4	3	3	3	13

Table B-6. Single-channel ground/airborne radio system.

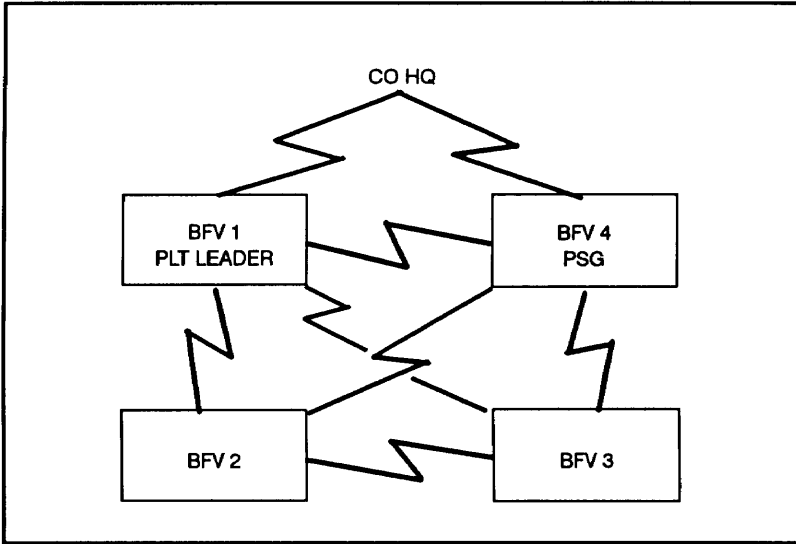

Figure B-3. Platoon radio net (mounted).

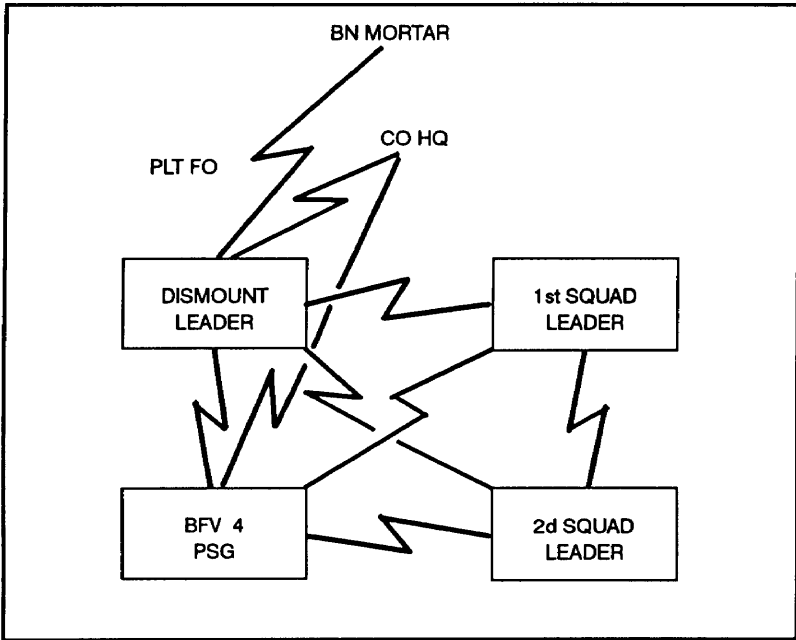

Figure B-4. Platoon radio net (dismounted).

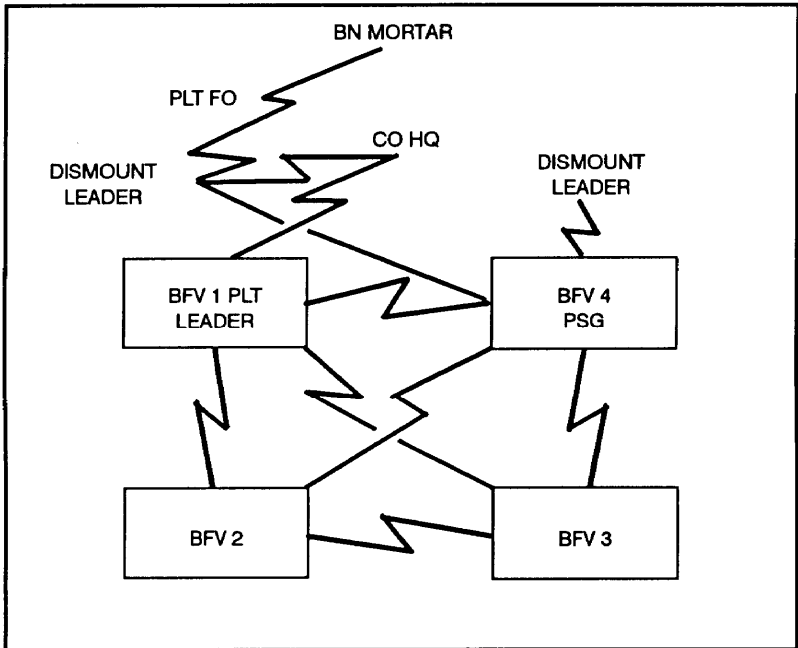

Figure B-5. Platoon radio net (mounted/dismounted).

B-7. PLATOON EARLY WARNING SYSTEM

The AN/TRS-2 platoon early warning system (PEWS) is a remote sensor system (REMS). The PEWS is organic to mechanized infantry rifle platoons. The system has 10 ground-implanted sensors. They transmit a signal (by radio or wire) to a receiving set that indicates movement in the area and which sensor is reporting. PEWS also differentiates between foot and vehicular movement. This device is ideal for monitoring avenues of approach masked by terrain or poor visibility. They should be employed along avenues of approach and in dead spaces or gaps forward of or between units. Each sensor can detect targets up to 15 meters from the sensor location. Its signals can be transmitted up to 1,500 meters.

B-8. WATER-CROSSING CAPABILITY

The BFV can ford up to 3.5 feet of water. With its water barrier erected, the BFV can swim water obstacles with currents up to 6.4 kilometers per hour. It has a maximum speed of 7.25 kilometers per hour while swimming. Erection of the swim barrier takes about 15 minutes for the M2A1 BFV and about 25 minutes for the M2A2. The BFV requires an exit bank slope

not greater than 17 percent and can fire both its 25-mm and 7.62-mm systems while swimming, though care must be taken not to hit the trim vane or water barrier (cannot fire below +7 degrees). The 25-mm can be fired in any direction while swimming; however, the turret should not be traversed because it may upset the balance of the vehicle. (See Chapter 6 for more information.)



B-9. SMOKE CAPABILITY

The BFV has onboard smoke capability. It has an onboard smoke generator and two smoke grenade launchers (four tubes each). The smoke grenade launchers are fired at the same time, and they produce a dense cloud of smoke around the vehicle. The launchers are loaded from the outside. Both the onboard smoke generator and smoke grenade launcher can be used for obscuring air-or ground-launched guided missiles. The onboard smoke generator is not effective if the fuel is JP8, and the temperature is higher than 40 degrees Fahrenheit.

B-10. LIMITED VISIBILITY CAPABILITY

Using the integrated sight unit in the thermal mode, the BC and gunner can detect and engage targets during any visibility condition, day or night. The daysight has normal optics. The nightsight uses thermal imagery that enables the gunner to see through most limited visibility conditions. This includes darkness, light, smoke, light foliage, camouflage, light fog, snow, and mist. Thermal sights should remain on during combat operations. They should be turned off periodically to prevent them from burning out.

a. The driver has excellent viewing capability using the AN/VVS-2 driver's night viewer. This viewer is an image intensification device that allows the driver to see clearly to his front. Therefore, the driver can handle his vehicle well on the roughest terrain. Also, during darkness, he can use the viewer to assist the BC and gunner in sensing rounds fired to the front. It is, however, prone to whiteout (fadeout) if light is shined directly at it (for example, spotlights, oncoming headlights, flashlights, sunlight). When installed, it obscures the speedometer/odometer. It can be battery powered (6 hours) or run directly off the vehicle power.

b. The BC can monitor the vehicle's night movement by wearing the AN/PVS-7 night vision goggles.

c. The gunner can assist and observe using the thermal sight while scanning the sector.

d. The platoon has several types of night vision devices available for dismount infantry operations. (Table B-7.)

EQUIPMENT	WEIGHT POUNDS	RANGE (METERS) STARLIGHT/ MOONLIGHT	BATTERY	FIELD OF VIEW (DEGREES)
PAS-7		8 to Infinity	silver zinc 6-volt	6/12
PVS-7A/B GOGGLES	1.5	150/300	BA 5567 1 ea or 2 ea AA	40
PVS-4 INDIVIDUAL SIGHT	3.5	400/600	BA 5567 2 ea	15
*PAS-13 THERMAL	4.13-4.85 (projected)	equal to or greater than weapon	BA 6847 2 ea	15, 15/9 9/3
TVS-5 CREW SIGHT	7.5	1000/1200	BA 5567 2 ea	9
VVS-2	18		BA 1567/V	45/38
PAQ-4A AIMING LIGHT	.93	300	BA 5567 1 ea or 2 ea A	N/A
**PAQ-4B AIMING LIGHT	TBD	600	BA 5567 1 ea or 2 ea AA	N/A
GVS-5 RANGE FINDER	5.0	200 to 9,900	BA 6516 or BB 516	7

*The PAS-13, thermal weapon sight (TWS), replaces PVS-4 and TVS-5 starting in FY 96. There will be three versions: light (4.13 pounds), medium (4.33 pounds), and heavy (4.85 pounds).

**The PAQ-4B is a product improvement of the PAQ-4A and will be fielded starting in FY 93.

Table B-7. Organic and supporting night vision equipment.

EQUIPMENT	WEIGHT (POUNDS)	RANGE (METERS) STARLIGHT/ MOONLIGHT	BATTERY	FIELD OF VIEW (DEGREES)
***PVS-6 RANGE FINDER	3.5	50 to 10,000	BA 6516 or BB 516	7
****LCMS	less than 35	approx antitank weapon	BA 6699 or vehicle	TBD
<p>***The PVS-6, mini-eyesafe laser infrared observation set (MELIOS), replaces the non-eyesafe GVS-5 range finder starting in FY 93.</p>				
<p>****LCMS, laser countermeasure system, is to be fielded starting in FY 94.</p>				

Table B-7. Organic and supporting night vision equipment

NOTE: The Bradley commander normally navigates from the open hatch position, because the AN/VVS-2 is too narrow to navigate effectively.

B-11. SUPPORTING WEAPONS

Supporting weapons provide the platoon and squad leaders additional firepower. Leaders must know how to effectively integrate the fires of these weapons with the fires of their organic weapons. (Tables B-8, B-9, and B-10.)

	M2 (.50 CAL)	MK19	M202 FLASH
WEIGHT (lbs)	84	76	26.7
LENGTH (in)	66	43	34.7
MAX RANGE (m)	6,765	2,212	N/A
ARMING RANGE (m)	N/A	18	N/A
MIN SAFE RANGE (m)	N/A	28	20
Rate of Fire			
CYCLIC (rpm)	500	375	N/A
RAPID (rpm)	40*	60	N/A
SUSTAINED (rpm)	40*	40	N/A
Effective Range			
AREA (m)	1,830	2,212	750
POINT (m)	1,200	1,500	200
STATIONARY (m)	N/A	N/A	N/A
MOVING (m)	N/A	N/A	N/A
BACKBLAST (m)			50
BURST RADIS (m)			20
Ammunition			
TYPE	BALL, AP, TRACER, API, API-T INCEN and BLANK	HEDP, HE, TP, and BUCKSHOT	
*With barrel change			

Table B-8. Supporting weapons.

WEAPONS	AMMUNITION		METERS		RATE OF FIRE
	MODEL	TYPE	MINIMUM RANGE	MAXIMUM RANGE	
107-mm M30	M329A2	HE	770	6,340	18 rounds per minute, then 9 rounds per minute for 5 minutes, then 3 rounds per minute sustained.
	M328A1	WP	720	5,650	
	M335A2	ILLUM	400	5,490	

Table B-9. Mortar characteristics.

	M106	M270	M110A2
CALIBER	155-mm	MLRS	8 in
MAX RANGE (For HE)	18,100		30,000 m
(m) PLANNING RANGE	14,600		30,000 m
(m) MIN RANGE (m)	DIRECT FIRE		DIRECT FIRE
DANGER CLOSE RANGE	600	600	600
Rate of Fire			
MAXIMUM (rpm)	4		
SUSTAINED (rpm)	2		
Projectile			
TYPE	HE, WP, ILLUM, SMOKE, CHEM, NUC, RAP, FASCAM, CPHD, AP/DPICM		HE, WP, ILLUM, APICM, CHEM, DPICM, HERA
Fuzes			
TYPE	PD, VT, CP, MT, MTSQ, DELAY		PD, VT, MT, MTSQ, CP, DELAY
LEGEND:			
AP — Armor-Piercing	ILLUM — Illumination		
APERS — Antipersonnel	MT — Mechanical Time		
APICM — Antipersonnel Improved	MTSQ — Mechanical Time		
CHEM — Chemical	Super Quick		
CP — Concrete Piercing	NUC — Nuclear		
CPHD — Copperhead	PD — Point Detonating		
DPICM —	RAP — Rocket Assisted Projectile		
FASCAM — Family of Scatterable Mines	VT — Variable Time		
HEAT — High-Explosive Plastic Tracer	WP — White Phosphorus		

Table B-10. Types of characteristics of field artillery.

APPENDIX C

STINGRAY EMPLOYMENT

The Stingray can be employed on the battlefield as an adjunct direct-fire system on M2/M3 BFVs. It is a combat protection system that increases the force survivability against threat optical devices. The Stingray can counter multiple ground and aerial threat weapons by detecting and jamming their optical sighting systems during day and night battlefield conditions before the threat system can be used to fire conventional weapons.

C-1. CAPABILITIES AND OPERATION

The Stingray can operate in automatic, semiautomatic, or manual modes depending on the control measures required to protect friendly forces and to obtain the maximum effect on the threat systems. The *automatic mode* can be used when there is no danger to friendly forces and when there is a large number of enemy systems. The *semiautomatic mode* can be used when more restrictive control measures are required. The semiautomatic mode restricts the Stingray system to its scanning function until the operator gives the command to fire. The *manual mode* can be used when control of the system is required either because the situation calls for restricted laser operations for security reasons or because manual mode is required by command restrictions. Manual control also permits rapid reorientation to a new sector when a higher priority threat appears or at the completion of one mission and a change of sector is required.

a. In combat, Stingray-equipped BFVs are employed as an integral part of a larger force. The Stingray-equipped BFV provides the platoon and force the capability to observe, detect, and jam threat ground and aerial targets beyond the direct-fire engagement range of other organic weapon systems. The Stingray-equipped BFV protects the force by jamming known enemy locations and by detecting enemy positions that might otherwise go undetected.

b. The Stingray is controlled the same as other direct-fire weapons on the battlefield. It will be assigned a sector of fire within the platoon and company sector. Stingray sectors will be included on the BFV range

card, and restrictions on the Stingray mode of operation will be noted in the range card remarks section. The platoon leader will employ the system in accordance with the commander's intent and plan.

c. The Stingray will normally be operated in the automatic or semiautomatic mode. There may be situations that require the use of the manual mode. This information will be included in the commander's OPOD to the platoon leader.

C-2. OFFENSIVE OPERATIONS

Stingray-equipped BFVs will assist in protecting the force by overmatching, identifying, and jamming threat optics. In the attack, they can be employed in both the supporting and main attack role. Upon consolidation or reorganization, Stingray-equipped BFVs should be positioned on the most likely avenues of approach to assist in detecting and defeating threat sighting systems.

a. **Movement to Contact.** During movement, the Stingray should be employed within the platoon formation to provide maximum protection to the platoon. It can be linked with other Stingrays to provide overlapping sectors of coverage. The Stingray can be employed with the overwatch or bounding element during bounding overwatch. In the overwatch, Stingrays operate in the semiautomatic mode to detect the presence of enemy without jamming. On engagement by the enemy, the Stingray can switch to the automatic mode to jam threat systems. Stingrays can operate in the semiautomatic mode when employed with the bounding element, and can be placed in the automatic mode to detect and jam threat systems on contact with the enemy.

b. **Attack.** In the attack, Stingray-equipped BFVs can be employed with the support-by-fire and assaulting elements.

(1) In the support-by-fire element, Stingrays can be positioned and employed initially as in the overwatch element. On order of the platoon leader, the Stingray can be placed in the automatic mode to suppress targets on the objective. Then, it shifts to another sector to isolate the objective during the maneuver element's assault on the objective.

(2) During a mounted assault, Stingrays can be positioned and employed as in the bounding element. Stingrays are oriented to the vehicle gun line, operating in the automatic mode to detect and jam enemy sights while the crew fights their onboard systems.

(3) During consolidation on the objective, Stingrays are assigned sectors to cover the most critical enemy avenues of approach. During this time, the Stingray operates in the automatic mode.

C-3. DEFENSIVE OPERATIONS

Stingray-equipped BFVs are positioned to take advantage of observation and fields of fire on the most critical avenues of approach to detect and jam targets beyond the normal engagement ranges for threat direct-fire weapons. Platoon Stingray-equipped BFVs are employed as a part of the company defense to protect exposed flanks, unprotected rear, or forward to provide early warning. Stingrays could also be part of a detachment left in contact.

a. The Stingray initially operates in the manual mode while the covering force and screening elements are forward in the security area. It is assigned sectors that will not interfere with the covering force's with drawal. Once the covering force passes through, the Stingray operates in the semiautomatic mode until contact is made with the enemy. On contact, the Stingray switches to the automatic mode.

b. During a counterattack, the Stingray is employed and operated in the same manner as in the attack.

C-4. SECURITY FORCE OPERATIONS

Platoons with Stingray-equipped BFVs perform security operations as a part of a larger force. They perform missions such as covering force or screen. Stingray-equipped BFVs are positioned to take advantage of observation and fields of fire of the most critical avenues of approach to detect and jam enemy optics.

a. **Covering Force Operations.** In order to help shape the battle, the Stingray operates in the semiautomatic mode on avenues of approach that the company commander wants the enemy to believe are lightly defended, and in the automatic mode on other enemy avenues of approach. Threat targets are jammed at maximum ranges to deprive the enemy of information about the density and disposition of friendly forces. Once the enemy moves within range, the platoon engages them with other onboard direct-fire systems. At the completion of their mission, the covering force disengages from enemy contact and withdraw through friendly forces in the main battle area. During withdrawal, the Stingrays operate in the automatic mode.

b. **Screening Missions.** Stingray-equipped platoons routinely perform front, flank, and rear screen missions. Stingrays operates in the semiautomatic mode during these missions and are employed to provide maximum area coverage along the screen line to detect any threat approach. To avoid detection, the Stingray operates in the manual mode.

C-5. RETROGRADE OPERATIONS

Stingray-equipped platoons perform retrograde operations as part of a larger force. In retrograde operations, the platoon participates in either a withdrawal under pressure or a withdrawal not under pressure. A withdrawal under pressure is conducted the same as a covering force withdrawal back through the MBA. A withdrawal not under pressure is conducted when the platoon or force is not in contact with the enemy. A detachment left in contact remains in position while the remainder of the platoon or company withdraws. The DLIC Stingray operates in the automatic mode, and the Stingray in the withdrawing platoon or force operates in the semiautomatic mode with an additional sector oriented toward the expected enemy approach. As the DLIC starts to withdraw, the remainder of the platoon or force provides overmatching fires to cover the DLIC's withdrawal.

APPENDIX D

M249 EMPLOYMENT

The M249 light machine gun is primarily a squad leader's weapon to be employed as an automatic rifle. Under certain circumstances, the platoon leader may designate it as a machine gun and with some adjustments, use it as a platoon weapon. This appendix addresses the distinction between the M249's two roles and the organizational, equipment, and employment differences involved in each.

D-1. AUTOMATIC RIFLE AND MACHINE GUN

The automatic rifle provides mobility and a high volume of fire up front in the assault or across the squad's position in the defense. It is the squad leader's weapon to use in the close fight. When configured as a machine gun, it includes a tripod, a T&E mechanism, and a spare barrel, and has a designated crew (gunner and assistant gunner). The M249 in its machine gun configuration trades mobility and flexibility for accuracy at longer ranges and endurance. Endurance means its ability to stay in the fight longer, because it normally has ammunition stockpiled or carried with it by its crew. As a machine gun, the M249 provides effective suppressive fires in support of the offense and accurate long-range fires in the defense.

D-2. M249 IN BRADLEY-EQUIPPED UNITS

The 25-mm gun and the coax machine gun provide the required high-volume, accurate firepower from a stable and mobile platform. Often, the BFVs are not in the best position to provide this kind of fire for the squads. When positioned to engage armored or mounted formations, their focus and primary targets are different from the rifle squads. They may be oriented in a different direction, since the squads are positioned to engage a dismounted enemy. Sometimes the terrain dictates a separation of the mounted section from the rifle squads making mutual support, in terms of interlocking fires, impossible. It is under these circumstances that the platoon leader may consider designating one or more of the squad's M249s as machine guns. The remainder of this appendix addresses this type of situation. References to platoon machine guns indicates automatic rifles designated for use as machine guns.

D-3. M249 AS AN AUTOMATIC RIFLE

Automatic rifles allow rifle squads to take a light automatic weapon with them in the assault. In the defense, they add the firepower of 10 or 20 riflemen without the addition of manpower. Characteristically, automatic rifles are light, fire rapidly, and have more ammunition than the rifles in the squad that they support. Each squad has three automatic rifles. No additional equipment configuration is needed, because the automatic rifleman fires the M249 either from the bipod mode or from various hand-held positions. The chief distinction in using M249s as automatic rifles is in the manner of their employment in offensive and defensive operations. Automatic rifles play two roles in the offense: base of fire and maneuver.

a. Offense—Base of Fire. In establishing a base of fire, automatic rifles can be the key weapons. They can also add their fires to that of the machine guns.

(1) **Engagement ranges.** Ranges will vary based primarily on the nature of the terrain. An average for engagement ranges is from 300 meters to about 800 meters. Among the small-arms weapons, only the machine guns can engage the enemy with any accuracy beyond 800 meters. Thus, if the remainder of the squad or fire team is going to employ its weapons as a base-of-fire element, then it must position itself within that 800-meter range from the objective. If the base-of-fire element closes to within 300 meters, the maneuver element may find itself without enough room for assaulting. The base-of-fire element may not be able to shift fires across the whole objective. It may not be able to engage to the flanks of the objective to help isolate it.

(2) **Targets.** In the bipod mode, automatic riflemen attempt to engage any enemy automatic weapons not engaged by the machine guns. Because their weapons are less accurate than the tripod-mounted machine gun at longer ranges, they will normally distribute their fires across the objective to suppress enemy soldiers or positions.

(3) **Positioning.** In addition to range considerations, squad and platoon leaders must consider that automatic rifles firing from the bipod mode should not attempt overhead fires. Their decreased stability makes them unsafe for firing over the heads of the maneuver element. This means that the base-of-fire element must engage from one side or another of the maneuver element's approach to the objective.

b. Offense—Maneuver. Automatic rifles form the backbone of the maneuver element in the assault. Squad and platoon leaders should consider the following in planning for the maneuver element.

(1) **Engagement ranges.** At ranges less than 300 meters, these weapons are fired either from the bipod or in an assault mode from the hip, shoulder, or underarm position.

(2) **Targets.** Automatic riflemen target any enemy supporting weapons that are being fired from fixed positions anywhere on the squad's portion of the objective. When the enemy's supporting weapons have been destroyed, or if there are none, the automatic riflemen distribute their fires over that portion of the objective that corresponds to their squad's or team's position. At these ranges, the automatic riflemen will be engaging point targets.

c. **Defense—Primary Role.** Although the automatic rifle is capable of adding long-range fires to the platoon leader's fight, it is primarily the squad leader's weapon. Just as the squads protect the platoon's BFs and machine guns from dismounted enemy assault, automatic rifles protect the squad. Their function is to provide a high volume of fire across the squad front and suppress or destroy a dismounted enemy force in its assault against the squad.

(1) **Engagement ranges.** Given a squad front of 100 to 125 meters and a squad sector of fire that extends to 300 meters forward of the squad positions, the engagement range of the automatic rifle across the front extends from 0 to 325 meters (Figure D-1, page D-4).

(2) **Targets.** If the automatic riflemen have not initiated their fires with the platoon machine gun, they pick up the fight as the enemy closes. They engage enemy automatic weapons and command and control elements. At closer ranges, they have more point targets than area targets. They achieve enfilading fires as the enemy closes. They must cover the entire squad sector of fire, or they must overlap with the fires of the other automatic rifles.

(3) **Positioning.** The protective role of the automatic rifles most often points to the classic technique of positioning them on the flanks to fire across the front of the squad. But the fundamental requirement is for the automatic rifles to be positioned to fire across a broad sector or in a wide arc. Distribution of fires, not concentration, is their goal. When final protective fires are called for, they lay across to their left or right limit and fire along the enemy side of the squad's final protective obstacle.

d. **Defense—Secondary Roles.** Automatic rifles may also lend their fires to the platoon's machine gun fires. This is done in two ways. First, they may either add their fires to the platoon engagement areas to concentrate fires on the enemy before he closes in an assault formation. At some point, however, when the enemy has begun closing, the platoon leader must relinquish control of the automatic rifles to the squad leader

to protect the squad against the enemy's assault. Even though the platoon leader or company commander initiates the final protective fires, the squad leader controls them. Second, automatic rifles may be used to cover specific narrow secondary avenues of approach when the platoon's machine guns have been positioned elsewhere against more dangerous avenues of approach.

(1) **Engagement ranges.** In a secondary role, automatic rifles initiate fires at greater ranges than usual (beyond 300 meters). However, their sectors of fire are narrower since they are concentrating their fires at predetermined targets.

(2) **Targets.** Automatic rifles positioned to augment the platoon machine guns engage the enemy according to specific criteria provided by the platoon leader. Firing at longer ranges, they engage area-type targets to suppress the enemy and disrupt his formations.

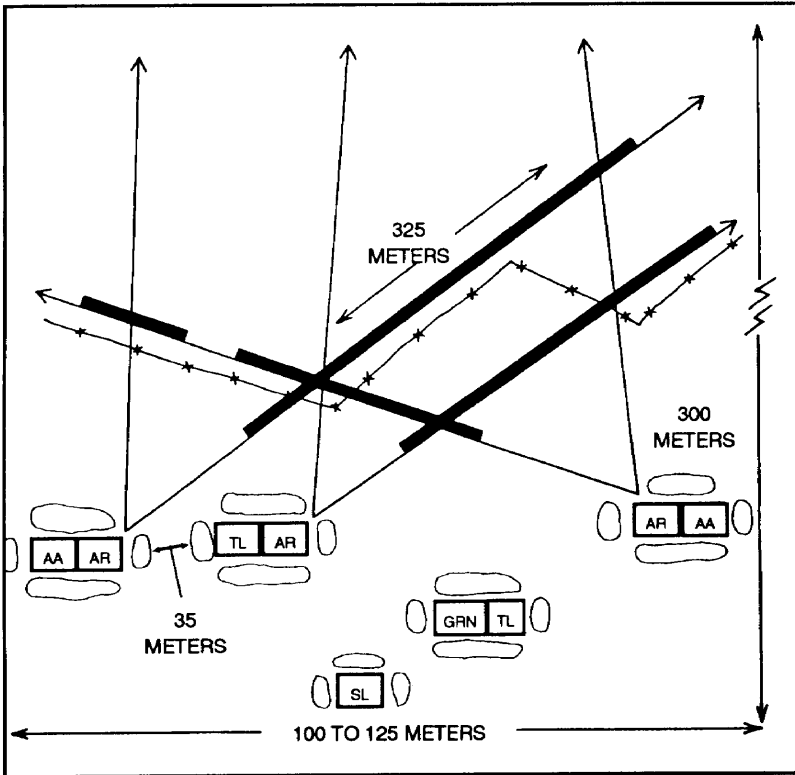

Figure D-1. M249 as automatic rifle (squad defense).

(3) Positioning. As an augmentation to the platoon's fire plan, automatic rifles may be positioned after the machine guns have been positioned. They may not be in the best position to support the squads' defense initially. Squad leaders should consider and plan for a supplementary position that allows the automatic riflemen to relocate and continue the fight in support of the squad as the enemy closes.

e. Rate of Fire. In either the offense or defense, automatic riflemen must restrict themselves to firing three-round bursts to maintain their effectiveness against enemy targets. The M249 in the bipod or hand-held mode moves too easily off its point of aim after three rounds and automatic riflemen must readjust their aim.

f. Ammunition. In the offense, the automatic rifleman is limited to what he can carry and tire on the move. Hence, while the automatic rifle affords a high volume of fire, it also rapidly consumes ammunition. Conservation and careful logistic planning become important. This problem is less critical in the defense, where ammunition can be stockpiled.

g. Automatic Rifle Marksmanship. When firing from the bipod or unsupported mode, automatic riflemen must know and apply the fundamentals of rifle marksmanship: steady position, aiming, breathing, and trigger control. Mastery of these fundamentals helps increase the effectiveness of the automatic rifleman's fires.

D-4. M249 AS A MACHINE GUN

Machine guns provide a high volume of accurate fire against dismounted enemy and light vehicle targets. In the offense, they are the key weapon in the base-of-fire element. In the defense, machine guns and dismounted antiarmor weapons are the key weapons. Platoon leaders position them first and then build the defense around them. Squads protect them from dismounted assaults.

a. Configuration. Since the Bradley-equipped rifle platoon does not have dedicated machine guns, the platoon leader must plan for and make adjustments once he has decided to designate one or more of the automatic rifles as a machine gun.

(1) Equipment. When used as a machine gun, the M249 requires a tripod, a T&E mechanism, and a spare barrel. These items increase the stability, the ability to make minute adjustments in aiming, and the ability to fire greater than three-round bursts.

(2) Squad organization. To assist in the handling and manipulation of this equipment, to carry the additional ammunition that the machine gun requires, and to provide additional observation (spotting of the rounds) and security, the machine gunner needs an assistant gunner.

The platoon leader designates another soldier to act as the assistant gunner. The designation of the automatic rifle as a machine gun to augment platoon fires means a corresponding reduction of the squad's firepower and strength.

(3) **Employment.** Machine guns support the platoon fight. The platoon leader positions them to concentrate fires in those spots where he wants to do the most damage to the dismounted enemy. He positions them to take advantage of grazing fire, maximum engagement ranges, and best observation of the target area; for example, objective (offense) or engagement area (defense). Machine guns combined with obstacles and tied in with the machine gun fires of adjacent platoons form the basis for mutual support in the defense.

(4) **Control.** The platoon leader either positions and controls the machine guns or designates one of the squad leaders to assist him.

b. Offense. Because machine guns are not as mobile as automatic rifles, they normally remain with and form the key weapon of the base-of-fire element. It is possible to bring a machine gun with the maneuver element for added firepower in the assault. But once it has set up, it becomes another base of fire and is quickly left behind by the rest of the element as it sweeps across the objective. It will spend more time displacing than firing. The following are additional considerations for using the machine gun in offensive missions.

(1) **Engagement ranges.** The base of fire is positioned between 300 and 800 meters from the objective. This is primarily a function of the ranges of the other small-arms weapons firing as part of the base of fire. If the base of fire must be outside 800 meters, the remainder of the base-of-fire element provides security for the machine guns.

(2) **Targets.** With the increased accuracy afforded by the tripod, machine guns can cover area targets better and shift from point target to point target faster. They primarily engage enemy machine gun teams or lightly armored vehicles.

(3) **Positioning.** Machine guns are capable of firing over the heads of friendly soldiers if terrain or maneuver constraints require it. They do not need to be placed on the flanks of the maneuver element's approach.

(4) **Employment.** Machine guns target key enemy weapons until the maneuver element masks its fires. Machine gunners then shift their fires to the flank opposite the one being assaulted. They continue to target any enemy automatic weapons that provide mutual support to his position or engage any groups of enemy counterattack. On signal, the machine guns and the base-of-fire element displace to join the maneuver element on the objective where they consolidate the position.

(5) **Control.** Machine guns remain under the control of the base-of-fire element leader until they linkup with the platoon on the objective.

c. **Defense.** Figure D-2 illustrates how a BFV platoon might defend two avenues of approach. The BFVs engage enemy vehicles on the mounted avenue of approach. Machine guns engage the enemy on the dismounted avenue, while automatic rifles protect the squads with interlocking fires.

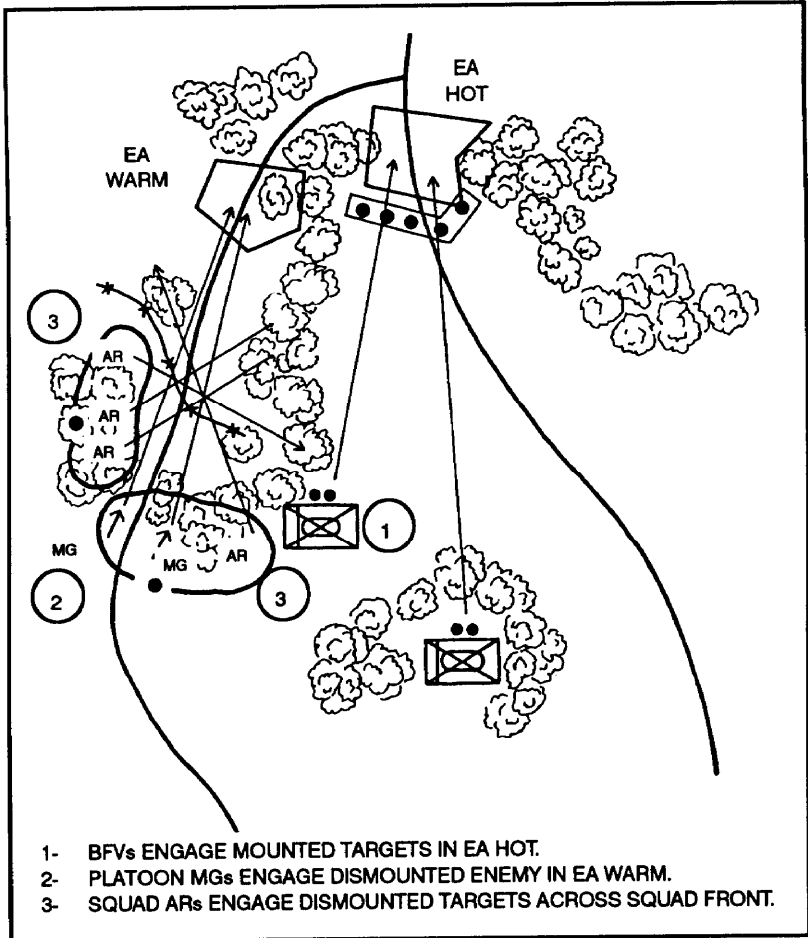

Figure D-2. Machine guns and automatic rifles in a platoon defense.

(1) **Engagement ranges.** Machine guns continue to fire accurately beyond 800 meters. Platoon leaders must weigh the advantages of stand-off (the ability of a weapon to out range an opposing weapon) against the loss of surprise entailed in engaging early with only a portion of the platoon's weapons. Platoon leaders should seek to build a machine gun defense that begins early and is tied with an obstacle system such that the initial fires of the machine guns force the enemy to deploy in a direction that leads him into the fires of the rifle squads.

(2) **Targets.** Machine guns target enemy automatic weapons, key weapons, and command and control elements. Once the enemy deploys, machine guns engage his supporting automatic weapons. As the enemy closes, if the machine guns have destroyed all of the enemy's supporting weapons, they can engage the assaulting troops with enfilading fires across the platoon front. Normally, because their goal is to concentrate fires, they will have narrower sectors of fire than automatic rifles. It is important for platoon leaders to identify secondary sectors for their machine guns that cover the platoon front. They also lend their fires to the platoon and company final protective fires on order.

(3) **Positioning.** In addition to all the positioning considerations above, platoon leaders must place their machine guns where they can provide fires into the desired engagement area, while taking advantage of as many of the effects of terrain as possible. When they position machine guns first, this becomes easier and it provides a focus for the positioning of the squads.

(4) **Employment.** Machine guns concentrate fires into designated engagement areas to destroy the enemy initially with a sudden burst of fires, then suppress him to prevent him from identifying friendly positions and from moving out of the engagement areas. Should the enemy begin deploying for an assault, machine guns continue to destroy or suppress maneuvering elements, but also look for and engage the enemy's supporting elements. As the enemy closes, the rifle squads engage assaulting troops while the machine guns suppress the enemy's overwatching automatic weapons.

(5) **Control.** Platoon leaders normally retain control of the machine guns. They may direct a squad leader to control the machine guns, but the squad leader needs to concentrate on the fires of the squad.

d. **Rate of Fire.** The machine gunner should fire five-to seven-round bursts to achieve a beaten zone. With the help of the assistant gunner in spotting rounds, machine gunners are better able to observe the effect of their fires on the target over increased distances.

e. Ammunition. The addition of an assistant gunner provides the capability of carrying more ammunition when the machine gun crew moves dismounted. The assistant gunner can also help in reloading the gun or observing the changing target array while the gunner reloads.

f. Machine Gun Marksmanship. Unlike the automatic rifle, the machine gunner must know more than the fundamentals of marksmanship. He must also master the manipulation of the T&E mechanism. He and the assistant gunner must be adept at spotting rounds and adjusting their aim to bring the impact of the rounds on target. A different set of fundamentals applies. Machine gun crews must know how to employ techniques such as identification of dead space; use of principle direction of fire, final protective fires, and range cards; construction of a machine gun position, and others. These techniques are in FM 23-14.

D-5. FUNDAMENTAL TECHNIQUES OF AUTOMATIC FIRE

The following describes and defines those fundamental techniques of fire common to automatic rifles and machine guns. More detailed information is in FM 23-14.

a. Techniques of Fire. Techniques of fire include direct lay, assault fire, overhead fire, and fire from a defilade position. Only automatic rifles use assault fire. Only machine guns can employ overhead fire.

(1) **Direct lay.** Gunnery and automatic riflemen use the direct-lay technique by aligning the sights of the weapon on the target. This is the easiest and quickest means of delivering fire.

(2) **Assault fire.** Automatic riflemen use assault fire when in close combat. Assault fire involves firing without the aid of sights. Automatic riflemen use the hip, shoulder, and underarm positions to achieve assault fire. Of these, the underarm position is the best when rapid movement is required. In all three positions, automatic riflemen adjust their fire by observing the tracers and the impact of the bullets in the target area. Additional considerations for automatic riflemen using assault fire include—

- Maintaining alignment with the rest of the assault element.
- Reloading rapidly.
- Aiming low and adjusting the aim upward toward the target.
- Distributing fires across the objective when not engaging enemy automatic weapons.

(3) **Overhead fire.** Gunnery can use overhead fire when there is sufficient low ground between the machine gun and the target area for the

maneuver of friendly forces. Gunners must accurately estimate the range to the target. Gunners must establish a safety limit; that is, an imaginary line, parallel to the target, where fire would cause casualties to friendly soldiers. Gun crews and leaders must be aware of this safety limit. Leaders must designate signals for the lifting or shifting of fires. Gunners should not attempt overhead fires if the terrain is level or slopes uniformly, if the barrel is badly worn, or if visibility is poor.

(4) **Defilade positions.** Defilade positions protect gunners from frontal or enfilading fires of the enemy. The advantages of cover and concealment are obvious; however, such positions may not provide the gunner or rifleman a view of some or all of the target area. In this instance, some other member of the platoon must observe the impact of the rounds and communicate adjustments to the gunner or rifleman. In determining whether or not to use a defilade position, gunners and leaders must consider the complexity of laying on the target, the gunner's inability to make rapid adjustments to engage moving targets, the ease with which targets are masked, and the difficulty in achieving grazing fires for a final protective line.

b. Characteristics of Fire. To assist the gunner and rifleman in better understanding the characteristics of fire for their weapons, the following definitions are helpful.

(1) **Trajectory.** Trajectory is the path of the bullet in flight. For the M249, the path of the bullet is almost flat at ranges of 300 meters or less. At ranges beyond 300 meters, the trajectory curves as the range increases.

(2) **Maximum ordinate.** This is the highest point the trajectory reaches between the muzzle of the weapon and the base of the target. It always occurs at a point about two-thirds of the distance from the weapon to the target. It also increases with the range.

(3) **Cone of fire.** This is the pattern formed by the different trajectories in each burst as they travel downrange. Vibration of the weapon, variations in ammunition, and atmospheric conditions all contribute to the different trajectories that make up the cone of fire.

(4) **Beaten zone.** This is the pattern formed by the rounds within the cone of fire striking the ground or the target. The size and shape of the beaten zone changes as a function of the range to and slope of the target. Gunners and automatic riflemen should engage targets so as to make maximum effect of the beaten zone. The simplest way to do this is to aim at the center base of the target. Most rounds will not fall over the target, and any that fall short will create ricochets into the target.

(5) **Danger space.** This is the space between the weapon and the target where the trajectory does not rise above 1.8 meters (the average

height of a standing soldier). This includes the area of the beaten zone. Gunners should consider the danger space of their weapons when planning overhead fires.

c. Class of Fire. The US Army classifies automatic weapon fires with respect to the ground, the target, and the weapon.

(1) Fire with respect to the ground includes grazing fire and plunging fire.

(a) *Grazing fire.* Automatic weapons achieve grazing fire when the center of the cone of fire does not rise more than 1 meter above the ground. When firing over level or uniformly sloping terrain, the M249 can attain a maximum of 600 meters of grazing fire.

(b) *Plunging fire.* Plunging fire occurs when weapons fire at long range, when firing from high ground to low ground, when firing into abruptly rising ground, or when firing across uneven terrain, resulting in a loss of grazing fire at any point along the trajectory.

(2) Fire with respect to the target includes enfilade, frontal, flanking, and oblique fire.

(a) *Enfilade fire.* Enfilade fire occurs when the long axis of the beaten zone coincides or nearly coincides with the long axis of the target. It can be frontal or flanking. It is the most desirable class of fire with respect to the target, because it makes maximum use of the beaten zone.

(b) *Frontal fire.* Frontal fire occurs when the long axis of the beaten zone is at a right angle to the front of the target, that means when firing directly into the front of a target.

(c) *Flanking fire.* Flanking fire is delivered directly against the flank of a target.

(d) *Oblique fire.* Gunners and automatic riflemen achieve oblique fire when the long axis of the beaten zone is at an angle other than a right angle to the front of the target.

(3) Fire with respect to the weapon includes fixed, traversing, searching, and traversing and searching fire.

(a) *Fixed fire.* Fixed fire is delivered against a stationary point target when the depth and width of the beaten zone will cover the target.

(b) *Traversing fire.* Traversing distributes fires in width by successive changes in direction.

(c) *Searching fire.* Searching distributes fires in depth by successive changes in elevation.

(d) *Traversing and searching fire.* This class of fire is a combination in which successive changes in direction and elevation result in the distribution of fires both in width and depth.

d. Types of Targets. Targets have both width and depth. The size of the target, stated in terms of the number of aiming points required to engage it completely, determines its type.

(1) **Point targets.** Point targets require the use of a single aiming point. Examples of this include bunkers, weapons emplacements, vehicles, and troops.

(2) **Area targets.** Area targets require more than one aiming point. Gunners and automatic riflemen use traversing, searching, or a combination of the two to engage the target. Area targets are distinguished as linear, deep, and linear with depth. Gunners and automatic riflemen engage deep targets using searching fire. They engage linear targets using traversing fire. Finally, they engage linear with depth targets using traversing and searching fire.

e. Rates of Fire. Automatic weapons fire in one of three rates: rapid, sustained, and cyclic. Normally gunners initially engage targets at the rapid rate to suppress the enemy quickly. Thereafter, they fire at a sustained rate to conserve ammunition. Automatic riflemen continue to use the three-round burst, refighting their weapons as quickly as possible. In engaging aerial targets, gunners and automatic riflemen use the cyclic rate.

(1) **Rapid fire.** Rapid fire is 200 rounds per minute in bursts of 5 to 7 rounds at 2- to 3-second intervals.

(2) **Sustained rate.** Sustained fire is 85 rounds per minute in bursts of 5 to 7 rounds at 4- to 5-second intervals.

(3) **Cyclic rate.** The normal cyclic rate of fire is 750 rounds per minute. To fire the cyclic rate, the gunner holds the trigger to the rear while the assistant gunner feeds ammunition into the weapon.

f. Techniques for Automatic Weapons in the Defense. Gunners and automatic riflemen use a number of techniques to ensure effective fires in defensive operations. Some techniques tie the characteristics of the weapons to the nature of the terrain. Others ensure distribution of fires across the squad or platoon front. Still others facilitate the concentration of fires against likely enemy avenues of approach, or in engagement areas bounded by tactical obstacles. Finally, others aid in maintaining accurate fires during limited visibility.

(1) **Sector of fire.** A sector of fire is an area that is required to be covered by the fire of an individual weapon or a unit. Most weapons are assigned both a primary and secondary sector of fire. Sectors of fire help to ensure distribution of fires across the squad or platoon front. By adding them to a sector sketch, squad or platoon leaders can verify that all of their individual and key weapons have achieved interlocking fires

within a squad or platoon sector. Within their sector of fire, gunners and automatic riflemen must identify all targets, target reference points, left and right limits, and dead space.

(2) **Final protective fires.** Final protective fires form an immediately available prearranged barrier of fire to stop enemy movement across defensive lines or areas. These fires consist of the final protective lines of automatic weapons, and the adjusted sheaves of mortars and artillery. Leaders strive to tie FPFs in with obstacles to hold the enemy at the point where friendly fires have their deadliest effect; that is, close-in, enfilading, grazing fire.

(3) **Final protective line.** A final protective line is a predetermined line along which automatic weapons place grazing fire to stop an enemy assault. As a security measure, all automatic weapons that have assigned FPLs remain laid on them unless the gunners or automatic riflemen are engaging other targets. FPLs are fixed in direction and elevation, excluding a small shift in elevation (search) to adjust for prone or crawling enemy soldiers or for irregularities in the terrain. Because they are fixed, FPLs can be fixed in all conditions of visibility.

(4) **Principal direction of fire.** A principal direction of fire is a priority direction of fire assigned to cover an area which provides good fields of fire or has a likely avenue of approach. It is also used to provide mutual support to an adjacent unit. Automatic weapons that do not have assigned FPLs are laid on a PDF when gunners or automatic riflemen are not engaging other targets.

(5) **Dead space.** Dead space defines that portion of an area where the waist of a soldier falls below a gunner's or automatic rifleman's point of aim. The most accurate method for determining dead space is to have one soldier walk the line of sight of the weapon (FPL or PDF) and make a pace count of those areas where he encounters dead space. Dead space can also be determined by observing the flight of tracer ammunition from a position behind and to the flank of the weapon.

(6) **Field-expedient methods.** The two most common field-expedient methods for laying the M249 in the bipod mode on predetermined targets are the notched-stake or tree-crotch and the horizontal log or board technique.

(a) **Notched-stake or tree-crotch technique.** This technique is effective for all conditions of visibility. It involves sighting the weapon on each target and marking the position and elevation of the stock with a notched-stake or tree-crotch. The automatic rifleman then scoops out a shallow groove to provide for the movement of the bipod legs and to keep the front end of the weapon aligned.

(b) *Horizontal log or board technique.* Automatic riflemen use this technique to mark sector limits and engage linear targets. It is best suited for flat, level terrain. It involves placing a log or board horizontally so that the weapon slides along it easily. The board may then be notched within its length to lay the weapon on a specific target reference point. It may also have limiting stakes placed to define the weapon's left and right limits.

g. Fire Control. Leaders control the engagements of their automatic weapons through the use of control measures, coordinating instructions, and fire commands.

(1) Control measures include, but are not limited to sectors of fire, target reference points, FPL or PDF, and prearranged signals.

(2) In the offense, coordinating instructions to gunners include instructions to initiate fires, a description of how the platoon leader sees the sequence of automatic weapon engagements, and the location of other friendly soldiers in the area. In the defense, the leader describes the presence and subsequent action of friendly soldiers to the front of the platoon position (scouts, passing units), the initiation and sequence of weapon engagements, priority targets, and the planned or probable shifting of forces to displace or counterattack.

(3) The signal to initiate fires or FPFs or any occasions not covered by planning can be bandied through the use of fire commands. Fire commands must be clear and concise. Gunners and automatic riflemen repeat all fire commands. Fire commands contain the following elements.

(a) *Alert.* The leader must specify WHO is to engage.

(b) *Direction.* The leader must clearly indicate the general direction of the target. He may do so orally (giving a general orientation or designating a reference point), by pointing, or by directing fires with tracer rounds from his own weapon. If he uses tracers, this becomes the last part of the command, and he directs "Watch my tracers."

(c) *Description.* Following the word "Target," the leader briefly describes the target, generally by the type of object: troops, vehicles, aircraft.

(d) *Range.* Leaders provide an estimate of the range to the target. Gunners and automatic riflemen use this estimate to set their rear sights, and to know how far out to look to identify the target.

(e) *Method of fire.* This element includes two parts: the manipulation (class of fire with respect to the weapon—fixed, traversing, searching, or traversing and searching), and the rate of fire. When the leader omits the rate of fire, the gunner assumes a rapid rate.

(f) *Command to open fire.* Timing the initiation of fires is important to gain surprise. Leaders may preface the command to commence firing

with “At my command” or “At my signal.” Gunners and automatic riflemen respond with “Ready” when they have identified the target and are ready to engage. Leaders then give the specified command or signal.

(4) Leaders adjust fires (direction, elevation, rate), identify new targets, cease fires, or terminate the alert, with subsequent fire commands.

(5) Finally, squads and platoons should establish SOPs governing the activities and automatic initiation, control, and cessation of fire for their automatic riflemen and gunners. These SOP items can include, standard sectors for observation and fires, when to initiate or return fires, priority targets, and how often to check with leaders once they have begun engaging the enemy.

GLOSSARY

Acronyms and Abbreviations

AA	assembly area; antiarmor specialist
AATF	air assault task force
ACEammunition, casualty, and equipment
ADA	air defense artillery
ammo	ammunition
AP	armor-piercing
APC	armored personnel carrier
APDS	armor-piercing discarding sabot
APDS-Tarmor-piercing discarding sabot-tracer
APFSD-Tarmor-piercing, fin-stabilized, discarding sabot-tracer
approx	approximately
AR	automatic rifleman
ARTEP	Army Training and Evaluation Program
A S A P	as soon as possible
ATGM	antitank guided missile
BCBradley commander
BFVBradley fighting vehicle
BMP	(a Threat vehicle)
bn	battalion
BP	battle position
BRDM	(a Threat scout car)
BSA	brigade support area
BTR	(a Threat vehicle)
C²command and control
cal	caliber
CAM	chemical-agent monitor

CAB close air support
CAP casualty collection point
cdr commander
cm combat engineer vehicle
CFV cavalry fighting vehicle
cGy centigray
cm centimeter
cocompany
coax coaxial
COMSEC communications security
CP command post
CAP combat reconnaissance patrol
CS combat support
C S S combat service support
CTA common table of allowance
CTT common task test
CVC combat vehicle crewman (helmet)

DA Department of the Army
DD Department of Defense
DLIC detachment left in contact
DS direct support
DTG date-time group
dvr driver

EA engagement area
ECCM electronic counter-countermeasures
ECM electronic countermeasures
eff effective
EMP electromagnetic pulse
EPW enemy prisoner of war
evac evacuate

FA field artillery
FEBA forward edge of the battle area
ISG first sergeant

FIST	fire support team
FM	field manual; frequency modulation
FO	forward observer
FPF	final protective fire
FPL	final protective line
FPWfiring port weapon
frag	fragmentary
FRAGO	fragmentary order
FSOfire support officer
ft	feet
FYfiscalyear
gal	gallon
GL	grid line
gnr	gunner
GPS	global positioning system
gm	grenadier
GRREG	graves registration
GSRgroundsumeillance radar
HEhigh explosive
HEAT	high-explosive antitank
HEDP	high explosive dual-purpose
HEI-T	high explosive incendiary-tracer
HEP	high-explosive plastic
hp	horsepower
hr	hour
HQheadquarters
IAWin accordance with
IFVinfantry fighting vehicle (Threat)
illum	illumination
in	inches
indiv	individual
ISUintegrated sight unit
I T Vimproved TOW vehicle

- KIA** killed in action
- km** kilometers
- kph** kilometers per hour

- LAW** light antitank weapon
- lb** pound
- LBE** load-bearing equipment
- LC** line of contact
- LCMS** laser countermeasure system
- LD** line of departure
- ldr** leader
- LOA** line of advance
- LOGPAC** logistics package
- LRP** logistic release point
- LZ** landing zone

- m** meter
- MAW** medium antitank weapon
- max** maximum
- MBA** main battle area
- mech** mechanized
- MEL** maximum engagement line
- MELIOS** mini-eyesafe laser infrared observation set
- METL** mission-essential task list
- MELIOS** mini-eyesafe laser infrared observation set
- METT-T** mission, enemy, terrain, troops and time available
- mg** machine gun
- mi** mile
- MICLIC** mine-clearing line charge
- MIJI** meaconing, intrusion, jamming, and interference
- MIJIREP** MIJI report
- min** minute
- mm** millimeter
- MOIC** missile ordnance inhibit circuit
- MOPP** mission-oriented protective posture
- MOS** military occupational specialty

MOUT	.military operations on urban terrain
mph	.milesperhour
MRB	.motorized rifle battalion (T'hreat)
MRE	.meal, ready-to-eat
MRP	.motorized rifle platoon ('llreat)
MST	.mechanicssupport team
MTP	.mission training plan
NBC	nuclear, biological, and chemical
NCO	noncommissioned officer
NLT	notlaterthan
No	number
NOD	night observation device
NVD	night vision device
OAKOC	observationand fields of fire,avenues of approach, key terrain,obstacles and movement, and cxwerand concealment
obj	objective
OP	observation post
OPCON	operational control
OPORD	operation order
ORP	objective rally point
PAC	personnel and administration center
PDF	principal direction of fire
PEWS	platoon early warning system
PFC	private first class
P I R	priority information requirement
PL	phase line
PLD	probable line of deployment
PLL	prescribed load list
plt	platoon
PMCS	preventive maintenance checks and services
POL	petroleum, oils, and lubricants
PP	passage point

PSG	platoon sergeant
psi	pounds per square inch
PSS	personnel support system
PZ	pickup zone
R	rifleman
RATELO	radiotelephone operator
RCLR	recoilless rifle
recon	reconnaissance
RAMS	remotesensor system
ROE	rules of engagement
RP	release point
RPG	(a Threat weapon)
rpm	revolutions per minute
RSTA	reconnaissance, surveillance, and target acquisition
SDT	self-development test
sec	second
SENSREP	sensitive items report
SFC	sergeant first class
SGT	sergeant
SIGSEC	signal security
SINGARS	single-channel ground/airborne radio system
SITREP	situation report
SL	squad leader
SMCT	soldier's manual of common tasks
SOI	signal operation instructions
SOP	standing operating procedure
SOSR	suppress, obscure, secure, and reduce
SP	start point
S p e c	specialist
SPOTREP	spot report
Sqd	squad
sr	senior
SSG	staff sergeant
STANAG	Standardization Agreement

STB	supertropical bleach
STP	soldier's training publication
T&E	traverse and elevation
TBD	to be determined
TEWT	tactical exercise without troops
TL	team leader
TM	technical manual; team
TNT	trinitrotouene (explosive)
TOW	tube-launched, optically tracked, wire-guided missile
TRP	target reference point
TWS	thermal weapon sight
UMCP	unit maintenance collection point
us	United States
vic	vicinity
VT	variable time
WIA	wounded in action
WP	white phosphorus
WRP	weapon referenee point
XO	executive officer

REFERENCES

SOURCES USED

These are the sources quoted or paraphrased in this publication.

QSTAG/AS 239. Standard Procedures for Infantry/Armored Fighting Vehicle Target Identification.

STANAG 2025/QSTAG/AS 591. Basic Military Road Traffic Regulations (Edition 5).

STANAG 2036/QSTAG/AS 518. Land Minefield Laying, Recording and Reporting Procedures (Edition 4).

STANAG 2044. Procedures for Dealing with Prisoners of War (PW) (Edition 4).

STANAG 2358. First Aid and Hygiene Training in NBC Operations (Edition 2).

DOCUMENTS NEEDED

These documents must be available to the intended users of this publication.

AR 350-42. Nuclear, Biological, and Chemical Defense and Chemical Warfare Raining. 14 October 1988.

AR 385-62. Regulations for Firing Guided Missiles and Heavy Rockets for Training, Target Practice and Combat. 5 January 1977.

AR 385-63. Policies and Procedures for Firing Ammunition for Training, Target Practice and Combat. 15 October 1983.

ARTEP 7-7J-MTP Mission Training Plan for the Bradley Fighting Vehicle Platoon, Section, and Squad. TBP?

*ARTEP 7-7J-DRILL. Battle Drills for the Bradley Fighting Vehicle Platoon, Section, and Squad. 8 December 1992.

ARTEP 7-8-MTP. Mission Training Plan for the Infantry Rifle Platoon and Squad. 30 September 1988.

DA Form 1155. Witness Statement on Individual. June 1966.

DA Form 1156. Casualty Feeder Report. June 1966.

*This source was also used to develop this publication.

- DA Form 1355-1-R. Hasty Protective Minefield Record (LRA).
July 1975.
- DA Form 2404. Equipment Inspection and Maintenance Worksheet.
April 1979.
- DA Form 2408. Equipment Log Assembly (Records). November 1991.
- DA Form 5517-R. Standard Range Card (LRA). February 1986.
- DA Pamphlet 350-38. Training Standards in Weapon Training.
September 1990.
- DD FORM 1380. US Field Medical Card. June 1962.
- FM 3-3. NBC Contamination Avoidance. 30 September 1986.
- FM 3-4. NBC Protection. 29 May 1992.
- *FM 3-5. NBC Decontamination. 23 July 1992.
- FM 3-50. Smoke Operations. 4 December 1990.
- *FM 3-100. NBC Defense Chemical Warfare, Smoke, and
Flame Operations. 23 May 1991.
- FM 5-34. Engineer Field Data. 14 September 1987.
- FM 5-100. Engineer Combat Operations. 22 November 1988.
- FM 5-102. Countermobility. 14 March 1983.
- FM 5-103. Survivability. 10 June 1985.
- FM 5-250. Explosives and Demolitions. 15 June 1992.
- FM 7-7. The Mechanized Infantry Platoon and Squad (APC).
15 March 1985.
- *FM 7-8. The Infantry Rifle Platoon and Squad. 22 April 1992.
- FM 12-6. Personnel Doctrine. 23 August 1989.
- FM 17-95. Cavalry Operations. 19 September 1991.
- FM 20-22. Vehicle Recovery Operations. 18 September 1990.
- FM 21-10. Field Hygiene and Sanitation. 22 November 1988.
- FM 21-26. Map Reading and Land Navigation. 30 September 1987.
- FM 21-60. Visual Signals. 30 September 1987.

*This source was also used to develop this publication.

- FM 21-75. Combat Skills of the Soldier. 3 August 1984.
- FM 21-76. Survival. 5 June 1992.
- FM 22-9. Soldier Performance in Continuous Operations.
12 December 1991.
- *FM 23-1. Bradley Fighting Vehicle Gunnery. 1 March 1991.
- FM 23-9. M16A1 Rifle and Rifle Marksmanship. 3 July 1989.
- FM 23-14. Squad Automatic Weapon (SAW), M249.
10 December 1985.
- FM 23-23. Antipersonnel Mine M18A1 and M18 (Claymore).
6 January 1966.
- FM 23-25. Launcher and Cartridge, 84-mm, M136 (AT4), HEAT.
22 November 1988.
- FM 23-30. Grenades and Pyrotechnic Signals. 27 December 1988.
- FM 23-31. 40-mm Grenade Launchers M203 and M79. 1 May 1972.
- FM 23-33. 60-mm HEAT Rocket, M72A1, M72A2 (Light Antitank
Weapon). 20 April 1979.
- FM 23-67. Machinegun, 7.62-mm, M60. 29 February 1984.
- FM 24-1. Signal Support in the AirLand Battle. 15 October 1990.
- FM 24-18. Tactical Single-Channel Radio Communications Techniques.
30 September 1987.
- *FM 25-100. Training the Force. 15 November 1988.
- *FM 25-101. Battle Focused Training. 30 September 1990.
- FM 26-2. Management of Stress in Army Operations. 29 August 1986.
- FM 44-8. Small Unit Self-Defense against Air Attack.
30 December 1981.
- FM 71-1. Tank and Mechanized Infantry Company Team.
22 November 1988.
- FM 71-2. The Tank and Mechanized Infantry Battalion Task Force.
27 September 1988.
- FM 90-4. Air Assault Operations. 16 March 1987.

*This source was also used to develop this publication.

FM 7-7J

- FM 90-10 (HTF). Military Operations on Urbanized Terrain (MOUT) (HOW to Fight). 15 August 1979.
- FM 90-10-1 (HT'F). An Infantryman's Guide to Urban Combat (How to Fight). 30 September 1982.
- FM 90-13 (HTF). River Crossing Operations (How to Fight). 1 November 1978.
- FM 90-13-1. Combined Arms Breaching Operations. 28 February 1991.
- FM 100-5. Operations. 5 May 1986.
- *FM 101-5-1. Operational Terms and Symbols. 21 October 1985.
- FM 101-10-1/1. Staff Officers' Field Manual-Organization, Technical and Logistical Data (Volume 1). 7 October 1987.
- STP 21-1 -SMCT. Soldier's Manual of Common Tasks Skill Level 1. 1 October 1990.
- STP 21-24-SMCT Soldier's Manual of Common Tasks, Skill levels 2/3/4. 1 October 1992.
- TM 3-6665-225-12. Operator's and Organizational Maintenance Manual: Chemical Agent, Automatic: M8, M10, M11, M12, M13, M14, M15, M16, M17, M18. 29 August 1975.
- TM 9-2350-252-10-1. Operator's Manual for Fighting Vehicle Infantry, M2; M2A1; Hull. 26 June 1992.
- TM 9-2350-252-10-2. Operator's Manual for Fighting Vehicle, Infantry, M2; M2A1; Turret. 9 July 1992.
- TM 9-2350-284-10-1. Operator's Manual for Fighting Vehicle, Infantry, M2A2; Turret. 4 September 1990.
- TM 9-2350-284-10-2. Operator's Manual for Fighting Vehicle, Infantry, M2A2; Turret. 30 January 1992.

*This source was also used to develop this publication.

INDEX

- air assault operations, 2-172**
 - air movement plan, 2-173
 - ground tactical plan, 2-172
 - landing plan, 2-173
 - loading plan, 2-173
 - staging plan, 2-173
- air defense, 4-47**
- ambush, 1-8, 2-84**
- assembly area procedures, 4-40**
- attack, 1-8, 2-85**
 - control measures, 1-9, 2-245
 - during limited visibility, 1-10, 2-243
 - initiative, 1-8
 - planning, 2-86
 - types of
 - ambush, 1-8, 2-84
 - deliberate, 1-8, 2-55, 2-86, 2-87, 4-33
 - dismounted, 2-89
 - mounted, 2-89
 - hasty, 1-8, 2-55, 2-86, 4-33
 - raid, 1-8
- avenues of approach, 2-9, 2-101 to 2-106**
- base-of-fire element, 2-55**
- basic tactics, 2-113**
- battle drills, 3-1, 3-2**
 - break contact (platoon or squad) (dismounted), 3-23
 - break contact (section or platoon) (mounted), 3-26
 - conduct initial breach of a mined wire obstacle (platoon), 3-48
 - enter building/clear room/building (platoon), 3-32
 - enter/clear a trench (platoon), 3-38
 - knock out bunkers (platoon), 3-44
 - platoon attack (dismounted), 3-3
 - platoon attack (mounted), 3-11
 - react to ambush (platoon or squad) (dismounted), 3-26
 - react to ambush (platoon) (mounted), 3-30
 - react to contact (platoon or squad) (dismounted), 3-18
 - react to contact (section or platoon) (mounted), 3-21
- Bradley fighting vehicle**
 - armor protection, B-4
 - characteristics of, B-1; Table B-1, B-2 to B-3
 - communications, B-13
 - crew compartment, B-3
 - limited visibility capability, B-16
 - mobility, B-4
 - operations with tanks, 2-193
 - organic weapons, B-4
 - dismounted, B-10
 - mounted, B-4
 - positions, 2-117, 2-140
 - smoke capability, B-16
 - supporting weapons, B-18
 - troop compartment, B-3
 - water-crossing capability, B-15
- breaching obstacles, 2-209, 2-210**

- combat power**, 1-2
 - firepower, 1-2
 - leadership, 1-3
 - maneuver, 1-2
 - protection, 1-3
- combat service support**, 2-170, 2-179, 4-57
 - planning, 2-179
 - resupply, 2-179
 - ammunition, 2-183
 - missiles, 2-183
 - petroleum, oil, and lubricants, 2-184
 - rations, 2-184
 - repair parts, 2-184
 - water, 2-184
 - resupply techniques, 2-180, 4-57
 - service-station, 2-180, 4-57
 - tailgate, 2-181, 4-57
- command and control**, 2-1, 2-86, 2-252, 4-4
- communication**, 4-6, 4-54
 - BFV communication systems, B-13
 - during limited visibility, 2-246
 - with tanks, 2-195, 2-196
- concept sketch**, 2-35, 2-36 to 2-39 (illus)
- consolidation**, 1-9, 2-55, 2-91, 4-34, 4-39
 - clock technique, 2-92
 - terrain feature technique, 2-92
- crew drills**, 3-1, 3-53
 - bail out (crew/fire team), 3-54
 - change formation (mounted) (platoon), 3-64
 - destroy or abandon an M2 Bradley fighting vehicle (crew), 3-102
 - dismount the vehicle (platoon/squad), 3-60
 - engage targets with the 25-mm automatic gun or 7-62-mm coax (crew), 3-96
 - engage targets with the TOW (crew), 3-99
 - evacuate injured personnel from a BFV, 3-55
 - execute action right or left (platoon), 3-85
 - extinguish a fire (crew), 3-58
 - load the 25-mm ammunition ready box (HE or AP), 3-92
 - load, unload, and stow grenades for the M257 smoke grenade launcher (crew), 3-101
 - mount the vehicle (platoon/section), 3-62
 - perform before-, during-, and after-combat-operation checks (crew), 3-105
 - reload a TOW launcher (crew), 3-97
 - remove a misfired TOW (crew), 3-100
 - secure at the halt (platoon), 3-80
- danger areas**, 2-54, 2-73
- dead space**, 2-123, 2-128
- deception operations**, 2-56
- defense**, 1-11 to 1-14, 2-93, 2-97, 4-35, 4-39
 - control measures, 1-13
 - coordination, 2-140
 - during limited visibility, 2-250
 - initiative, 1-12
 - positions, 2-94
 - preparation for, 2-93
 - priority of work, 2-114, 4-36
 - types of
 - deliberate, 1-12
 - hasty, 1-12, 2-84

- defensive techniques, 2-101**
 - battle position, 2-101
 - perimeter, 2-109
 - reverse slope, 2-110
 - sector, 2-106
 - strongpoint, 2-108
- delay, 2-168**
- deliberate attack, 1-8, 2-55, 2-86, 2-87**
 - dismounted, 2-89
 - mounted, 2-89
- deliberate defense, 1-12**
- disengagement, 2-162**
 - dismount element, 2-165
 - by fire teams, 2-165
 - by thinning the lines, 2-166
 - of squads, 2-166
 - simultaneous, 2-165
 - vehicle element, 2-166
 - by section, 2-167
 - by vehicle, 2-167
 - simultaneous, 2-167
- dismounted formations, 2-60, 2-238, 4-24**
 - fire team, 2-60, 4-24
 - file, 2-62, 4-24
 - wedge, 2-62, 4-24
 - platoon, 2-65, 4-24
 - column, 2-65, 4-24
 - line, 2-65, 4-24
 - squad, 2-63, 4-24
 - column, 2-63, 4-24
 - file, 2-64, 4-24
 - line, 2-63, 4-24
- Dragon**
 - employment of, 2-50, 2-118
 - positions, 2-119, 2-152
- duties and responsibilities, A-5**
 - antiarmor specialist, A-9
 - automatic rifleman, A-9
 - Bradley commander, 2-115, 4-38, A-7
 - driver, A-9
 - fire support team, A-10
 - forward observer, A-10
 - radiotelephone operator, A-10
 - grenadier, A-9
 - gunner, A-9
 - platoon aidman, A-9
 - platoon leader, 2-114, 4-36, A-6
 - platoon master gunner, A-8
 - platoon radiotelephone operator, A-10
 - platoon sergeant, 2-115, 4-37, A-6
 - squad leader, 2-116, 4-38, A-8
 - team leader, 2-116, 4-39, A-8
- enemy prisoners of war**
 - handling of, 2-188
- fighting positions, 2-140**
 - AT4, 2-152
 - BFV, 2-117, 2-140
 - crew-served weapons, 2-142 (illus)
 - Dragon, 2-152
 - Flash, 2-152
 - hasty, 2-146
 - individual, 2-141 (illus)
 - light antitank weapon, 2-152
 - machine gun, 2-150
 - one-soldier, 2-147
 - platoon, 2-136
 - preparation of, 2-143
 - squad, 2-135
 - three-soldier, 2-148
 - two-soldier, 2-148
 - trenches, 2-153
 - vehicle, 2-154; Table 2-6, 2-156 to 2-157
 - deliberate, 2-155
 - hasty, 2-155

- fire commands**, 2-46, 2-178
- fire control**, 2-40, 2-78, 2-97, 2-118, 2-140, 4-49
 - methods of, 2-42
 - principles of, 2-40
- fire distribution**, 2-40, 2-42, 2-47, 2-78, 2-97, 4-49
 - area, 2-47
 - methods of, 2-47
 - point, 2-47
- fire patterns**, 2-47
 - cross, 2-48
 - depth, 2-50
 - frontal, 2-48
- firepower**, 1-2
- fire support**, 2-174, 4-48
 - direct
 - from BFVs, 2-178
 - indirect fire, 2-175
 - call for fire, 2-176
 - positioning of forward observer, 2-175
 - planning, 2-86, 2-174
 - defensive, 2-174
 - offensive, 2-174
- firing position**, 2-134
 - alternate, 2-135
 - primary, 2-135
 - supplementary, 2-135
- foot marches**, 4-31
- formations**, 1-6, 2-53, 2-57, 2-86, 4-24
 - control, 1-6
 - dismounted, 2-60, 2-238, 4-24
 - flexibility, 1-6
 - mounted, 2-57, 2-238, 4-24
 - security, 1-6
- fragmentary order**, 2-4, 2-31
- hasty attack**, 1-8, 2-55, 2-86
- hasty defense**, 1-12, 2-84
- health services support**, 2-191, 4-58
 - company evacuation, 2-191
 - platoon evacuation, 2-191
- infiltration**, 1-10 to 1-11
 - during limited visibility, 2-247
- inspections**, 2-12
- LAW/AT4**, 2-52
 - employment of, 2-52
 - positions, 2-152
- leadership**, 1-3
- limited visibility**, 2-235
 - attacks, 2-243
 - control measures, 2-245
 - BFV capability, B-16
 - command and control, 2-252
 - coordination, 2-253
 - defense, 2-250
 - equipment, 2-235
 - infiltration, 2-247
 - movement, 2-71, 2-237
 - techniques, 2-238
 - movement formations, 2-237
 - dismounted, 2-238
 - mounted, 2-238
 - naviation techniques, 2-72, 2-239
 - compass and odometer, 2-239
 - global positioning systems, 2-239
 - gyro compass, 2-239
 - fires, 2-239
 - radars, 2-239
 - offense, 2-237
 - positions, 2-251
 - occupation of, 2-254
 - vehicle identification during, 2-243
- linkup**, 2-169
- load plans**, 4-44

- M249 employment**, D-1
 - automatic rifle, D-1, D-2
 - machine gun, D-1, D-5
 - techniques of fire, D-9
- maintenance**, 2-185, 4-57
 - direct support, 2-187
 - recovery, 2-187
 - responsibility of, 2-185
 - unit, 2-186
- maneuver**, 1-2, 1-9, 1-13, 2-86
- maneuver element**, 2-55
- maximum engagement line**, 2-123, 2-129
- mechanized infantry employment**, 1-5
- minefields**, 2-202
 - hasty protective, 2-202
 - phony, 2-209
 - point, 2-209
- mission tactics**, 2-1 to 2-3
- mission-oriented protection posture**, 2-225
- mounted formations**, 2-57, 2-238, 4-25
 - coil, 2-60, 4-25
 - column, 2-57, 4-25
 - echelon, 2-57, 4-25
 - herringbone, 2-60, 4-25
 - line, 2-57, 4-25
 - wedge, 2-59, 4-25
- movement**, 1-5, 2-57, 2-87, 2-94, 4-24
 - limited visibility, 2-237
 - platoon, 1-5
 - with tanks, 2-193
 - dismount element in lead, 2-194
 - tanks in lead, 2-193
- movement techniques**, 1-6, 2-53, 2-67, 4-25
 - dismounted, 2-70
 - bounding overwatch, 2-71
 - during limited visibility, 2-71
 - traveling, 2-70
 - traveling overwatch, 2-71
- individual, 2-73
- with tanks, 2-73
- by water, 2-73
- mounted, 2-67
 - bounding overwatch, 2-67
 - traveling, 2-67
 - traveling overwatch, 2-67
- movement to contact**, 1-7, 2-54, 2-77
 - heavy resistance, 2-80
 - light resistance, 2-79, 2-80
 - medium resistance, 2-80, 2-82
- nuclear, biological, and chemical operations**, 2-215, 4-45
 - nuclear environment, 2-215
 - alarm for, 2-217
 - protective measures, 2-217
 - radiological monitoring, 2-217
 - warning of explosion or hazard, 2-216
 - weapons effects, 2-215
 - chemical and biological environment, 2-218
 - alarm for chemical hazard or attack, 2-218
 - conditions of unmasking, 2-224
 - decontamination techniques, 2-226
 - skin, 2-228
 - personal wipedown, 2-228
 - operator's spraydown, 2-228
 - MOPP gear exchange, 2-229
 - vehicle washdown, 2-230
 - detailed troop decontamination, 2-230
 - detailed equipment decontamination, 2-230

- detection equipment, 2-221
- effects of chemical agents, 2-218
- individual actions after attack, 2-224
- individual actions before attack, 2-223
- individual actions during attack, 2-223
- mission-oriented protection posture, 2-225
- protective measures, 2-219
- observation post**, 2-56, 2-231, 4-53
 - actions at, 2-232
 - communication with, 2-232
 - cover and concealment of, 2-231
 - equipping, 2-232
 - location of, 2-231
 - manning, 2-232
 - observation from, 2-231
 - squad-sized, 2-233
 - thermal sight surveillance from, 2-232
 - visual terrain search from, 2-233
- obstacles**, 1-13, 2-9, 2-196
 - breaching, 2-209, 2-210, 2-213
 - bypassing, 2-209
 - employment of, 2-196
 - minefields, 2-202
 - hasty protective, 2-202
 - phony, 2-209
 - point, 2-209
 - types of
 - existing, 2-197
 - reinforcing, 2-199
 - wire, 1-14, 2-199
 - protective, 1-14
 - supplementary, 1-14
 - tactical, 1-14
- offense**, 1-7 to 1-11, 2-77, 4-32
 - limited visibility, 2-237
 - operation order**, 2-4, 2-10, 2-13, 2-14 (illus)
 - operation overlay**, 2-31
 - company (attack), 2-32 (illus)
 - company (defend), 2-33 (illus)
 - platoon (defend), 2-34 (illus)
 - orders**
 - fragmentary, 2-4, 2-31, 4-9
 - operation, 2-4, 2-10, 2-13, 2-14 (illus), 4-9
 - warning, 2-4, 2-6 (illus), 4-9
 - organic weapons**, B-4
 - dismounted, B-10
 - mounted, B-4
 - organization**, A-1
 - dismount element, A-5
 - mounted element, A-1
 - patrols**, 2-56, 4-53
 - personnel service support**, 2-187, 4-57
 - platoon early warning system**, B-15
 - platoon positions**, 2-136
 - platoon reference guide**, B-1
 - protection**, 1-3
 - raid**, 1-8
 - range cards**, 2-122
 - preparation of, 2-124
 - reconnaissance**, 2-10, 2-54, 2-170, 2-171
 - rehearsals**, 2-11
 - techniques of, 2-12
 - types of
 - briefback, 2-11
 - full-force, 2-12
 - reduced-force, 2-12
 - relief in place**, 2-171

- reorganization**, 1-9, 1-13, 2-91, 2-92, 2-98, 4-34, 4-39
- reports**, 4-9
- ammo status, 4-18
 - equipment status, 4-15
 - meaoning, intrusion, jamming, and interference, 4-14
 - medical evacuation request, 4-21
 - NBC-1, observer's initial report, 4-22
 - NBC-4, report of dose-rate measurement, 4-23
 - personnel battle loss, 4-21
 - POL status, 4-20
 - sensitive items, 4-13
 - situation, 4-12
 - spot, 4-11
 - stand-to, 4-12
- resupply**, 2-179, 2-182
- ammunition, 2-183
 - missiles, 2-183
 - petroleum, oil, and lubricant, 2-184
 - rations, 2-184
 - repair parts, 2-184
 - techniques, 2-180
 - water, 2-184
- resupply techniques**, 2-180
- service-station, 2-180
 - tailgate, 2-181
- retirement**, 2-169
- sector sketches**, 2-136
- platoon, 2-138, 2-139 (illus)
 - squad, 2-136, 2-137 (illus)
- sectors of fire**, 2-122
- security**, 1-14, 2-53, 4-51
- active measures of, 1-15
 - at danger areas, 2-54
 - deceptive measures of, 2-56
 - during movement, 1-14, 2-53
 - in the defense, 1-15, 2-55
 - in the offense, 1-15, 2-54
 - passive measures of, 1-15, 2-56
- squad positions**, 2-135
- stay-behind operations**, 2-170
- planning, 2-170
 - types of
 - deliberate, 2-170
 - unplanned, 2-170
- Stingray**, C-1
- capabilities, C-1
 - employment
 - defense, C-3
 - offense, C-2
 - retrograde, C-4
 - security force, C-3
- supporting weapons**, B-18
- tactical road marches**, 4-25 to 4-31
- tactical standing operating procedures**, 4-1
- air defense, 4-47
 - combat service support, 4-57
 - command and control, 4-4
 - communication, 4-6
 - estimate of the situation, 4-8
 - movement, 4-24
 - orders and reports, 4-9
 - fire distribution and control, 4-49
 - fire support, 4-48
 - NBC, 4-45
 - operations, 4-32
 - assembly area procedures, 4-40
 - load plans, 4-44
 - smoke producers, 4-42
 - operations security, 4-51
 - task organization, 4-3

- target reference points, 2-44, 2-123**
- task organization, 4-3**
- terrain model, 2-35, 2-39 (illus)**
- trenches, 2-153**
- troop-leading procedure, 2-3**

- vehicle positions, 2-154**
 - deliberate, 2-155
 - hasty, 2-155
- vehicle recovery, 2-187**

- warning order, 2-4, 2-6 (illus)**
- weapons emplacement, 2-116**
 - automatic rifles, 2-122
 - BFV, 2-117
 - Dragon, 2-118
 - grenade launchers, 2-121
 - machine gun, 2-121
- weapons reference point, 2-124, 2-131**
- withdrawal, 2-160**
 - disengagement, 2-162
 - not under pressure, 2-160
 - under pressure, 2-160

FM 7-7J
7 MAY 1993

By Order of the Secretary of the Army:

GORDON R. SULLIVAN
General, United States Army
Chief of Staff

Official:

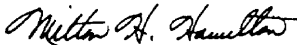

MILTON H. HAMILTON
Administrative Assistant to the
Secretary of the Army
03775

DISTRIBUTION:

Active Army, USAR, and ARNG: To be distributed in accordance with DA Form 12-11E, requirements for FM 7-7J, Mechanized Infantry Platoon and Squad (Bradley) (Qty rqr block no. 0794).